

1. PART NO. EXPRESSION :

STF0402100YZF
 (a) (b) (c) (d)(e)(f)

- (a) Series code
- (b) Dimension code
- (c) Inductance code : 100 = 10.0uH
- (d) Tolerance code : Y = ±40%
- (e) X, Y, Z : Standard part
- (f) F : Lead Free

2. CONFIGURATION & DIMENSIONS :

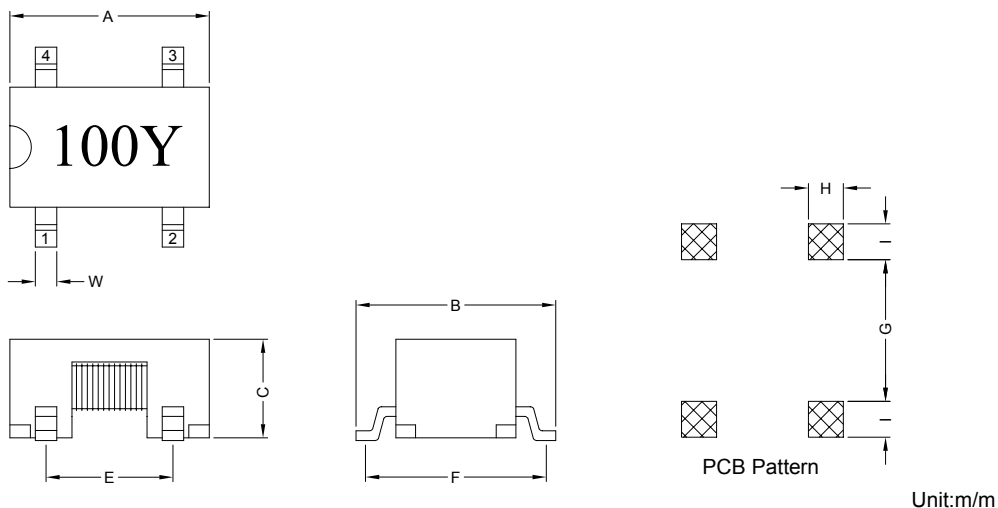

A	B	C	E	F	G	H	I	W
4.60±0.3	5.00±0.3	2.50±0.3	3.00±0.3	4.60±0.3	3.40 Ref.	0.80 Ref.	1.20 Ref.	0.50±0.1

3. SCHEMATIC :

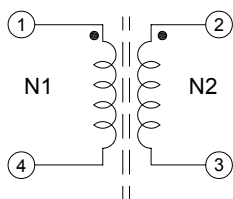

"●": Polarity



RoHS Compliant

NOTE : Specifications subject to change without notice. Please check our website for latest information.

09.05.2008

4. MATERIALS :

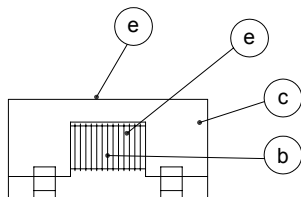

- (a) Core : Ferrite Core
- (b) Wire : Enamelled Copper Wire
- (c) Base : Phenolic
- (d) Adhesive : Epoxy
- (e) Ink : Bon Margue

5. GENERAL SPECIFICATION :

- a) Temp. rise : 45°C Max. at rated current
- b) Storage temp. : -40°C to +125°C
- c) Operating temp. : -40°C to +80°C
- d) Resistance to solder heat : 260°C. 10secs

6. ELECTRICAL CHARACTERISTICS :

Part No.	Inductance L1 , L2 (μH)	DC Resistance N1 , N2 (Ω)	Rated Current (A)	Impedance (Ω)	Frequency Range (MHz)
STF0402100YZF	10.0±40%	0.035 Max.	1.40	80 Min.	10 ~ 1000
STF0402400YZF	40.0±40%	0.070 Max.	1.25	250 Min.	5 ~ 500
STF0402850YZF	85.0±40%	0.135 Max.	0.90	400 Min.	3 ~ 300
STF0402151YZF	150.0±40%	0.220 Max.	0.50	600 Min.	2 ~ 100
STF0402221YZF	220.0±40%	0.350 Max.	0.45	800 Min.	1 ~ 50

* Hi-Pot Test (N1-N2) : 500VAC 60Hz 3mA 1 Minute



RoHS Compliant

NOTE : Specifications subject to change without notice. Please check our website for latest information.

09.05.2008



SUPERWORLD ELECTRONICS (S) PTE LTD

7. IMPEDANCE VS. FREQUENCY :

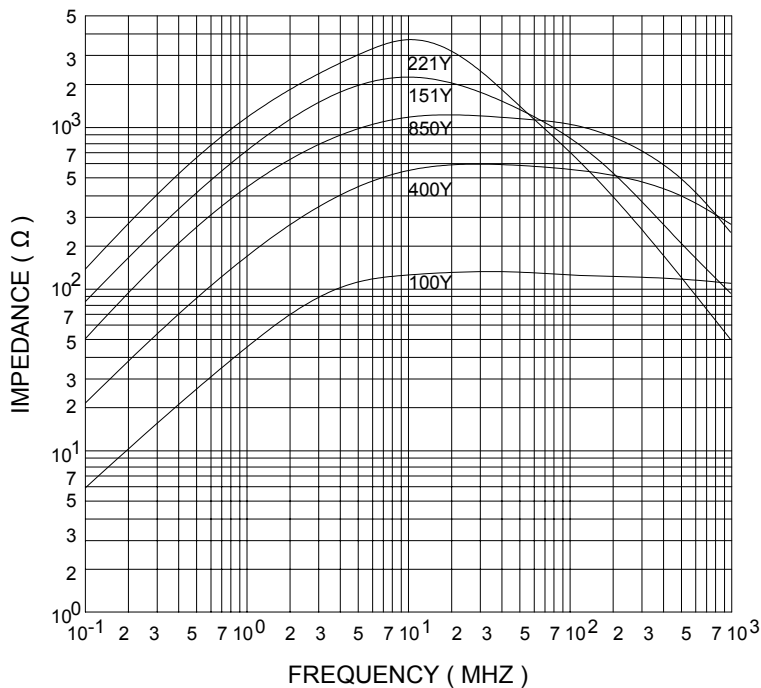

Measuring Circuit :

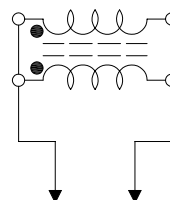

RF Impedance Analyzer

NOTE : Specifications subject to change without notice. Please check our website for latest information.



RoHS Compliant

09.05.2008



RECOMMENDED SOLDERING CONDITIONS REFLOW SOLDERINGS

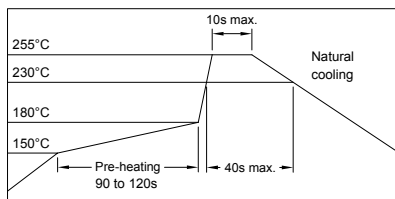

8. PACKAGING INFORMATION :

(1) CONFIGURATION

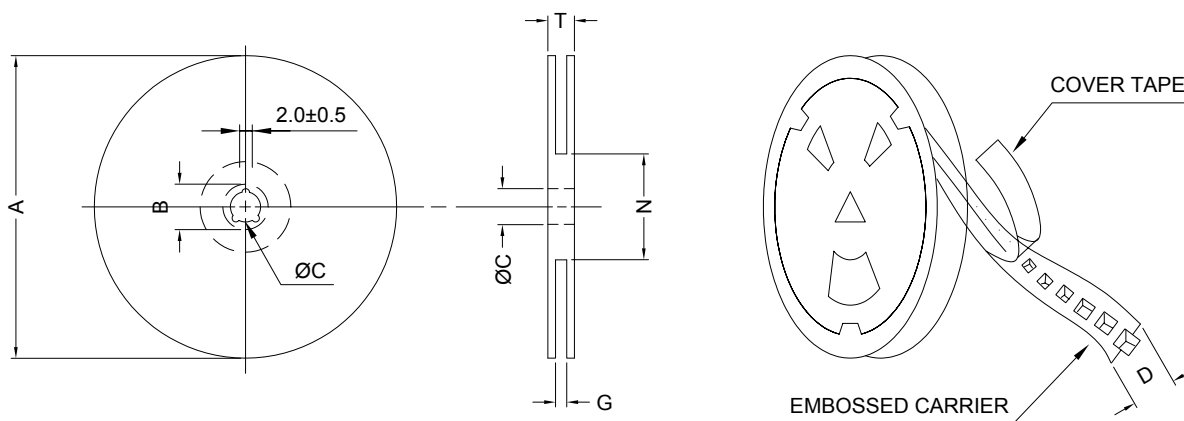

* CARRIER TAPE WIDTH : D

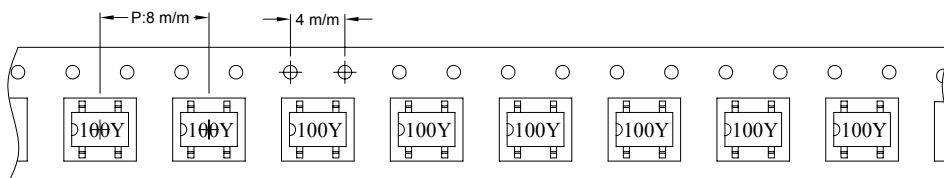

(2) DIMENSIONS

Unit:m/m

STYLE	A	B	C	D	G	N	T
13-16	330	21±0.8	13	16	18 ⁺⁰	50 ⁻⁰	22.4

(3) Q'TY & G.W. PER PACKAGE

SERIES	INNER : REEL			OUTER : CARTON		
	Q'TY (PCS)	G.W. (gw)	STYLE	Q'TY (PCS)	G.W. (Kg)	SIZE (cm)
STF0402	2000	600	13-16	12000	7.1	40 x 40 x 24



RoHS Compliant

NOTE : Specifications subject to change without notice. Please check our website for latest information.

09.05.2008

9. RELIABILITY AND TEST CONDITION :

TEST ITEM	SPECIFICATION	TEST CONDITION
SOLDERABILITY	MORE THAN 90% OF THE TERMINAL ELECTRODE SHALL BE COVERED WITH FRESH SOLDER.	PREHEAT : 125±25°C FOR 60 SECONDS SOLDER : 99%Sn/0.3%Ag/0.7%Cu OR EQUIVALENT SOLDER TEMP. : 245±5°C FLUX : ROSIN DIP TIME : 4±1 SECONDS
THERMAL SHOCK TEST (TEMP. CYCLE)	INDUCTANCE SHALL NOT CHANGE MORE THAN ±20%	ROOM TEMP. → -25±2°C 15 MINUTES 30 MINUTES ROOM TEMP. → 85±2°C 15 MINUTES 30 MINUTES TOTAL : 50 CYCLES
HUMIDITY RESISTANCE TEST		TEMPERATURE : 40±2°C HUMIDITY : 90 ~ 95% APPLIED CURRENT : PER SPEC. TIME : 500 HOURS
HIGH TEMP. RESISTANCE TEST		TEMPERATURE : 85±2°C APPLIED CURRENT : PER SPEC. TIME : 500 HOURS



RoHS Compliant

NOTE : Specifications subject to change without notice. Please check our website for latest information.

09.05.2008



SUPERWORLD ELECTRONICS (S) PTE LTD

10. UL CARD :

OBMW2 **November 30, 2000**
Magnet Wire - Component

PACIFIC ELECTRIC WIRE & CABLE (SHENZHEN) CO LTD **E201757**
607 BAOLONG INDUSTRIAL ESTATE LONGGANG, SHENZHEN
GUANGDONG CHINA

Mtl Dsg	Coating Type		ANSI	TI
	BC	TC	Type	
UEW/U	Polyurethane	—	—	130
PEW/U	Polyester	—	MW5-C	155°C
PEWH/U	Modified Polyester	—	MW30-C	180
PEW-NY/U	Polyester	Polyamide	MW24-C	155
HAI/U	Polyester(Amide)(Imide)	Polyamideimide	MW35,73	200
UEW-NY/U	Polyurethane	Polyamide	MW80-C	155
			MW28-C	130

Marking: Company name and material designation or marked designation on package or reel, and Recognized Component Mark.

See General Information Preceding These Recognitions

1/3/2001 **Underwriters Laboratories Inc.** **Card 1 of 2**

QMFZ2 **January 15, 1991**
Component-Plastics

SUMITOMO BAKELITE CO LTD **E41429 (M)**
(11-cont. from I card)

PM-9630	BK	0.40	94V-0	150	150	150	—	—	—	—	—
		0.51	94V-0	150	150	150	0	0	—	—	—
		3.18	94V-0	150	150	150	0	1	0	4	3
PM-8315	BK	0.50	94V-0	150	150	150	3	0	0	—	—
PM-8315J	BN	0.71	94V-0	150	150	150	2	0	0	—	—
		1.47	94V-0	150	150	150	0	2	0	—	—
		3.05	94V-0	150	150	150	0	1	0	5	4
		6.10	94V-0	150	150	150	0	1	0	5	4
PM-8315K	BK	0.78	94V-1	150	150	150	—	—	—	—	—
		1.52	94V-0	150	150	150	—	—	—	—	—
PM-8320J	BK	0.71	94HB	150	150	150	—	—	—	—	—
PM-8330	BK	0.71	94V-1	150	150	150	—	—	—	—	—
		1.57	94V-0	150	150	150	—	—	—	—	—
PM-8400	BK	0.71	94HB	150	150	150	—	—	—	—	—
PM-9830	BK	0.69	94V-0	150	150	150	0	0	—	—	—
		3.18	94V-0	150	150	150	0	0	0	4	3

Reports: March 29, 1985: May 14, 1974: September 16, 1971: September 16, 1971:
 September 16, 1971: September 16, 1971: March 29, 1985.

Replaces E4142911 dated February 28, 1990. **(Cont. on J card)**
683540014 N7047 Underwriters Laboratories Inc. ® **D11/0043416**



RoHS Compliant

NOTE : Specifications subject to change without notice. Please check our website for latest information.

09.05.2008