



# RBI Series

## Pressure sensors with analog and digital output

### FEATURES

- 0...10 inch H<sub>2</sub>O to 0...100 psi, 0...±5 inch H<sub>2</sub>O to 0...±100 psi, absolute, gage or differential pressure
- 0.5...4.5 V analog output and digital readout via I<sup>2</sup>C-bus
- Precision ASIC signal conditioning
- Temperature compensated
- Sensortech PRO services

### MEDIA COMPATIBILITY

To be used with non-corrosive, non-ionic working fluids such as clean dry air, dry gases and the like.

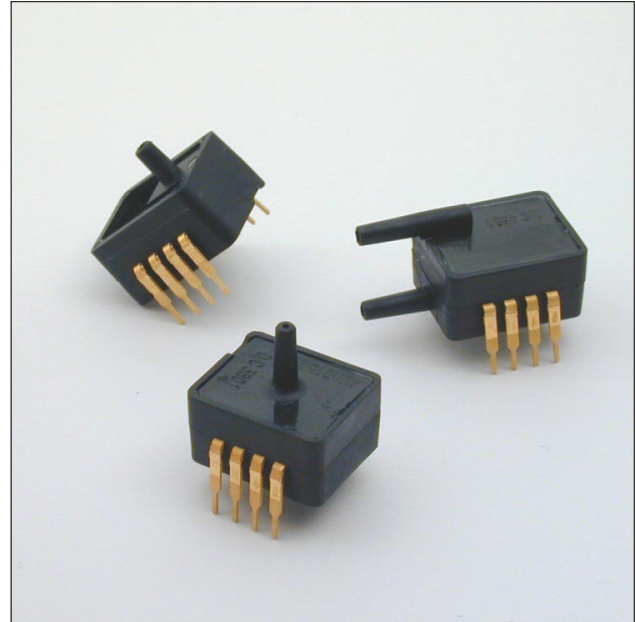

### SPECIFICATIONS

#### Maximum ratings

Supply voltage $V_S$ max. 6.50 $V_{DC}$	4.75 V to 5.25 $V_{DC}$
Output current Sink	2 mA
Source	2 mA
Lead temperature (2 - 4 sec.)	250 °C
Temperature ranges Compensated	0 to +85 °C
Operating	-20 to +105 °C
Storage	-40 to +125 °C
Vibration	10 g at 20 - 2000 Hz
Shock RBAP...	100 g for 11 ms
RBAH...	50 g for 11 ms

#### Caution!

The sensors are not reverse polarity protected. Incorrect applications of excitation voltage or ground to the wrong pin can cause electrical failure. Application of supply voltage above the maximum can cause electrical failure.

### ELECTRICAL CONNECTION

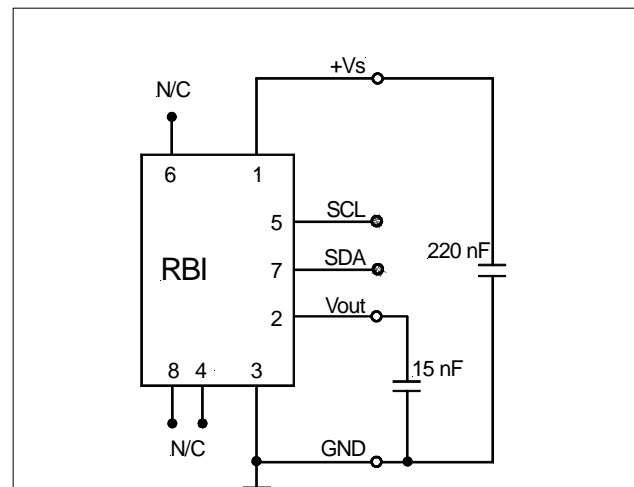

#### Note:

Capacitor 220 nF required between +Vs and GND and 15 nF between Vout and GND.

It is important to place the capacitors as close to the pins as possible!

Pins 4, 6 and 8 are internal device connections and should not be connected for any reason!



# RBI Series

## Pressure sensors with analog and digital output

### PRESSURE RANGES SPECIFICATIONS

( $V_S = 5.0 V_{DC}$ ,  $T_A = 25^\circ C$ , analog output signal is **ratiometric** to  $V_S$ , digital output signal is **not ratiometric** to  $V_S$ )

Part number	Pressure range	Burst pressure <sup>1</sup>		Sensitivity (typ.)				
RBIH005DB	0...±5	"H <sub>2</sub> O	3	psi	0.400	V/ "H <sub>2</sub> O	328	counts/ "H <sub>2</sub> O
RBIH010DB	0...±10		3		0.200		164	
RBIH010DU	0...10		3		0.400		328	
RBIP015AU	0...15	psi(a)	30	psi(a)	0.267	V/psi	218	counts/ psi
RBIP030AU	0...30		60		0.133		109	
RBIP100AU	0...100		150		0.040		33	
RBIP001(G,D)U	0...1	psi(g)	5	psi(g)	4.00	V/psi	3277	counts/ psi
RBIP005(G,D)U	0...5		20		0.80		655	
RBIP015(G,D)U	0...15		30		0.267		218	
RBIP030(G,D)U	0...30		60		0.133		109	
RBIP100(G,D)U	0...100		150		0.040		33	
RBIP001DB	0...±1		5		2.00		1638	
RBIP005DB	0...±5	20	0.40	328				
RBIP015DB	0...±15	psi(d)	30	psi(d)	0.133	V/psi	109	counts/ psi
RBIP030DB	0...±30		60		0.067		55	
RBIP100DB	0...±100		150		0.020		16	

#### Specification notes:

1. If maximum burst pressure is exceeded, even momentarily, the package may leak or burst, or the pressure sensing die may fracture.
2. Full Scale Span (FSS) is the algebraic difference between the output signal for the highest and lowest specified pressure.
3. Total accuracy is the combined error from offset and span calibration, linearity, pressure hysteresis, and temperature effects. Linearity is the measured deviation based on a straight line. Hysteresis is the maximum output difference at any point within the operating pressure range for increasing and decreasing pressure. Calibration errors include the deviation of offset and full scale from nominal values.
4. Delay time between sampling and signal change at the output.
5. The smallest change in the output voltage, given any change in pressure.
6. This is the maximum temperature shift for offset when measured between 0...85 °C relative to the 25 °C reading.



# RBI Series

## Pressure sensors with analog and digital output

### PERFORMANCE CHARACTERISTICS

( $V_s = 5.0 V_{DC}$ ,  $T_A = 25^\circ C$ , analog output signal is **ratiometric** to  $V_s$ , digital output signal is **not ratiometric** to  $V_s$ )

#### All RBIH...

Characteristics	Min.	Typ.	Max.	Units
Total accuracy (0...85 °C) <sup>3</sup>			±2.5	%FSS
Temperature effect on offset <sup>6</sup>			±100	mV
Sample rate	100			Hz
Response delay <sup>4</sup>	2.73		14.11	ms
Quantization step <sup>5</sup>		3		mV
Current consumption		6		mA

#### All RBIH...U (unidirectional devices)

Characteristics	Min.	Typ.	Max.	Units
ANALOGUE PERFORMANCE CHARACTERISTIC				
Zero pressure offset	0.40	0.50	0.60	V
Full scale span (FSS) <sup>2</sup>		4.00		
Full scale output	4.40	4.50	4.60	
DIGITAL PERFORMANCE CHARACTERISTIC				
Zero pressure offset	327	410	492	counts
Full scale span (FSS) <sup>2</sup>		3277		
Full scale output	3604	3686	3768	

#### All RBIH...B (bidirectional devices)

Characteristics	Min.	Typ.	Max.	Units	
ANALOGUE PERFORMANCE CHARACTERISTIC					
Zero pressure offset	2.40	2.50	2.60	V	
Full scale span (FSS) <sup>2</sup>		4.00			
Output	at max. specified pressure	4.40	4.50		4.60
	at min. specified pressure	0.40	0.50		0.60
DIGITAL PERFORMANCE CHARACTERISTIC					
Zero pressure offset	1966	2048	2130	counts	
Full scale span (FSS) <sup>2</sup>		3276			
Output	at max. specified pressure	3604	3686		3768
	at min. specified pressure	327	410		492



# RBI Series

## Pressure sensors with analog and digital output

### PERFORMANCE CHARACTERISTICS

( $V_s = 5.0 V_{DC}$ ,  $T_A = 25^\circ C$ , analog output signal is **ratiometric** to  $V_s$ , digital output signal is **not ratiometric** to  $V_s$ )

#### All RBIP...

Characteristics	Min.	Typ.	Max.	Units
Total accuracy (0...85°C) <sup>3</sup>			±2.0	%FSS
Temperature effect on offset <sup>6</sup> RBIP...GU, ...DU, ...DB			±80	mV
Sample rate	100			Hz
Response delay <sup>4</sup>	2.73		14.11	ms
Quantization step <sup>5</sup>		3		mV
Current consumption		6		mA

#### All RBIP...U (unidirectional devices)

Characteristics	Min.	Typ.	Max.	Units
ANALOGUE PERFORMANCE CHARACTERISTIC				
Zero pressure offset	0.42	0.50	0.58	V
Full scale span (FSS) <sup>2</sup>		4.00		
Full scale output	4.42	4.50	4.58	
DIGITAL PERFORMANCE CHARACTERISTIC				
Zero pressure offset	347	410	473	counts
Full scale span (FSS) <sup>2</sup>		3276		
Full scale output	3624	3686	3750	

#### All RBIP...B (bidirectional devices)

Characteristics	Min.	Typ.	Max.	Units	
ANALOGUE PERFORMANCE CHARACTERISTIC					
Zero pressure offset	2.42	2.50	2.58	V	
Full scale span (FSS) <sup>2</sup>		4.00			
Output	at max. specified pressure	4.42	4.50		4.58
	at min. specified pressure	0.42	0.50		0.58
DIGITAL PERFORMANCE CHARACTERISTIC					
Zero pressure offset	1985	2048	2111	counts	
Full scale span (FSS) <sup>2</sup>		3276			
Output	at max. specified pressure	3624	3686		3750
	at min. specified pressure	347	410		473



### INTRODUCTION

The RBI is capable to generate a digital output signal. It runs a cyclic program, which will store a corrected 12-bit sensor value about every 10 ms within the output registers of the internal ASIC. In order to use the pressure transducer for digital signal readout, the device should be connected to a bidirectional I<sup>2</sup>C-bus.

According to the I<sup>2</sup>C-bus communication specification, the bus is controlled by a master device, which generates the clock signal, controls the bus access and generates START and STOP conditions. The RBI is designed to work as a slave, hence it will only respond to requests from a master device.

The I<sup>2</sup>C-bus master-slave concept requires a unique address for each device. The RBI has a hard coded slave address (1111000xb), therefore it is **not** possible to access more than one RBI on the same I<sup>2</sup>C-bus line.

### DIGITAL I<sup>2</sup>C INTERFACE

The RBI complies with the following protocol (FIGURE I):

**Bus not busy:** During idle periods both data line (SDA) and clock line (SCL) remain HIGH.

**START condition (S):** HIGH to LOW transition of SDA line while clock (SCL) is HIGH is interpreted as START condition. START conditions are always generated by the master. Each request for the current pressure value must be initiated with a START.

**STOP condition (P):** LOW to HIGH transition of SDA line while clock (SCL) is HIGH determines STOP condition. STOP conditions are always generated by the master. More than one request for the current pressure value can be transmitted without generation of intermediate STOP condition.

**DATA valid (D):** State of data line represents valid data when, after START condition, data line is stable for duration of HIGH period of clock signal. Data on line must be changed during LOW period of clock signal. There is one clock pulse per bit of data.

**Acknowledge (A):** Data is transferred in pieces of 8 bits (1 byte) on serial bus, MSB first. After each byte receiving device – whether master or slave – is obliged to pull data line LOW as acknowledge for reception of data. Master must generate an extra clock pulse for this purpose. When acknowledge is missed, slave transmitter becomes inactive. It is on master either to send last command again or to generate STOP condition in that case.

**Slave address:** Each device connected to the bus has a unique slave address. After generating a START condition, the master has to transmit the slave address for the RBI with a READ command: \$F1. The RBI must not be accessed with a WRITE command (\$F0) as the correct function of the device can not be guaranteed in this case (note: a power-down power-up change will force the sensor to use factory data again).

**DATA operation:** The RBI starts to send 2 data bytes containing the current pressure value placed in the output registers.

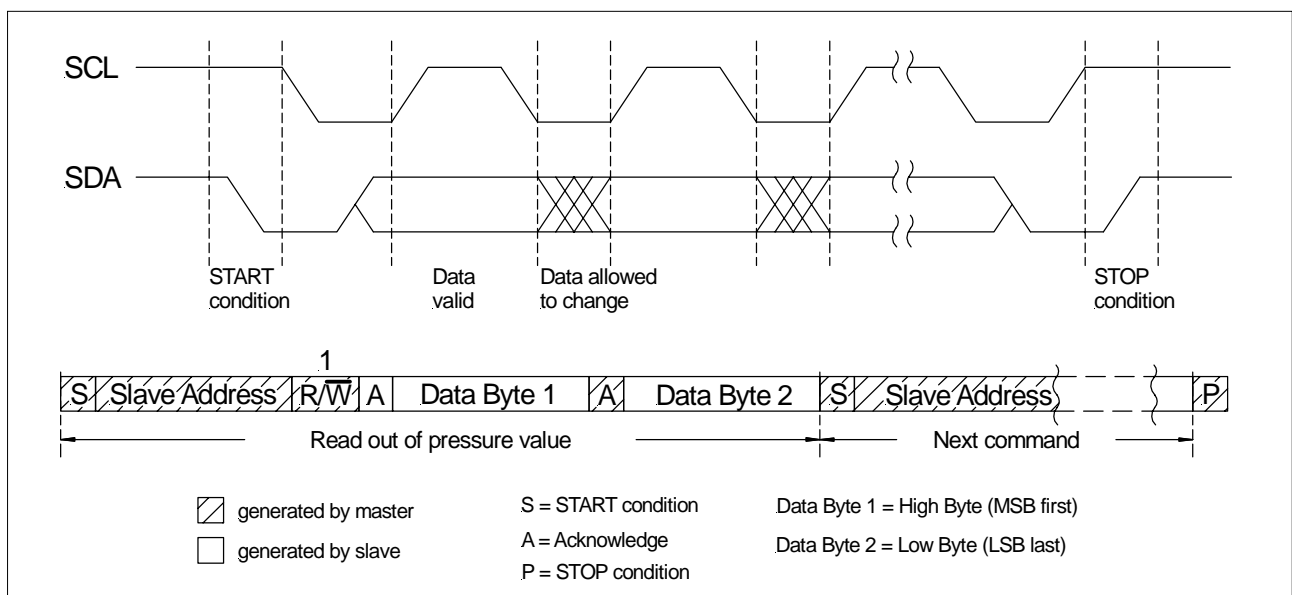

FIGURE I: I<sup>2</sup>C-BUS Protocol



# RBI Series

## Pressure sensors with analog and digital output

### I<sup>2</sup>C INTERFACE PARAMETERS

Parameter	Symbol	Conditions	Min.	Typ.	Max.	Unit
Input high level			90		100	% of V <sub>s</sub>
Input low level			0		10	
Output low level		(open drain, IOL= -4 mA)			10	
Pull up current		(pins SCL and SDA)	5		20	μA
Load capacitance SDA					400	pF
SCL clock frequency	F <sub>SCL</sub>		---		100	kHz
Bus free time between STOP and START condition	t <sub>BUF</sub>		4.7			μs
Hold time (repeated) START condition	t <sub>HD,STA</sub>	to first clock pulse	4.0			μs
LOW period of SCL	t <sub>LOW</sub>		4.7			μs
HIGH period of SCL	t <sub>HIGH</sub>		4.0			μs
Setup time repeated START condition	t <sub>SU,STA</sub>		4.7			μs
Data hold time	t <sub>HD,DAT</sub>		0			ns
Data setup time	t <sub>SU,DAT</sub>		250			ns
Rise time of both SDA and SCL	t <sub>R</sub>		---		300	ns
Fall time of both SDA and SCL	t <sub>F</sub>		---		300	ns
Setup time for STOP condition	t <sub>SU,STO</sub>		4			μs
Input filter spike suppression	t <sub>SP</sub>	spikes on SDA or SCL of that length are suppressed			50	ns

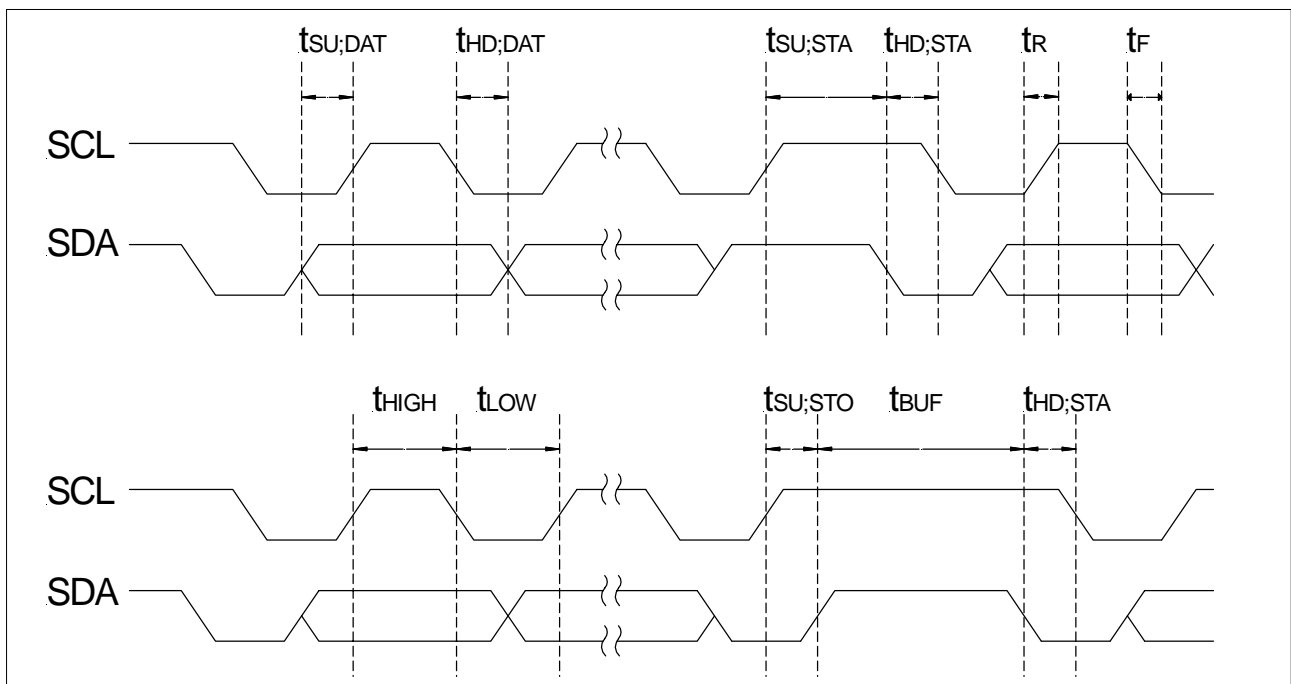

FIGURE II: Timing characteristics of the I<sup>2</sup>C interface



# RBI Series

## Pressure sensors with analog and digital output

### PHYSICAL DIMENSIONS

#### Differential (D) package

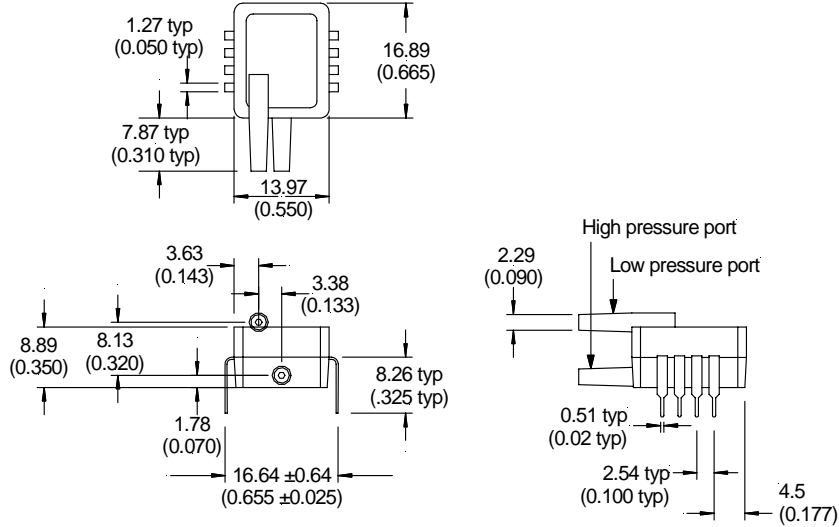

#### Gage (G) package

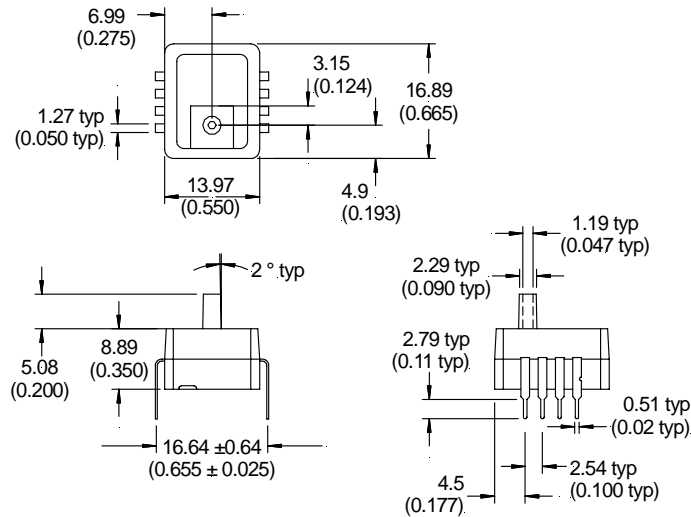

#### Absolute (A) package

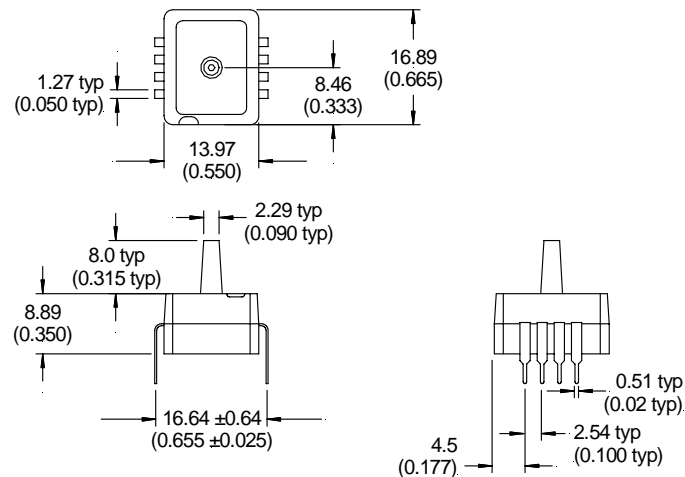

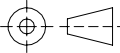
  
third angle projection  
dimensions in mm (inches)



# RBI Series

## Pressure sensors with analog and digital output

### ELECTRICAL CONNECTIONS

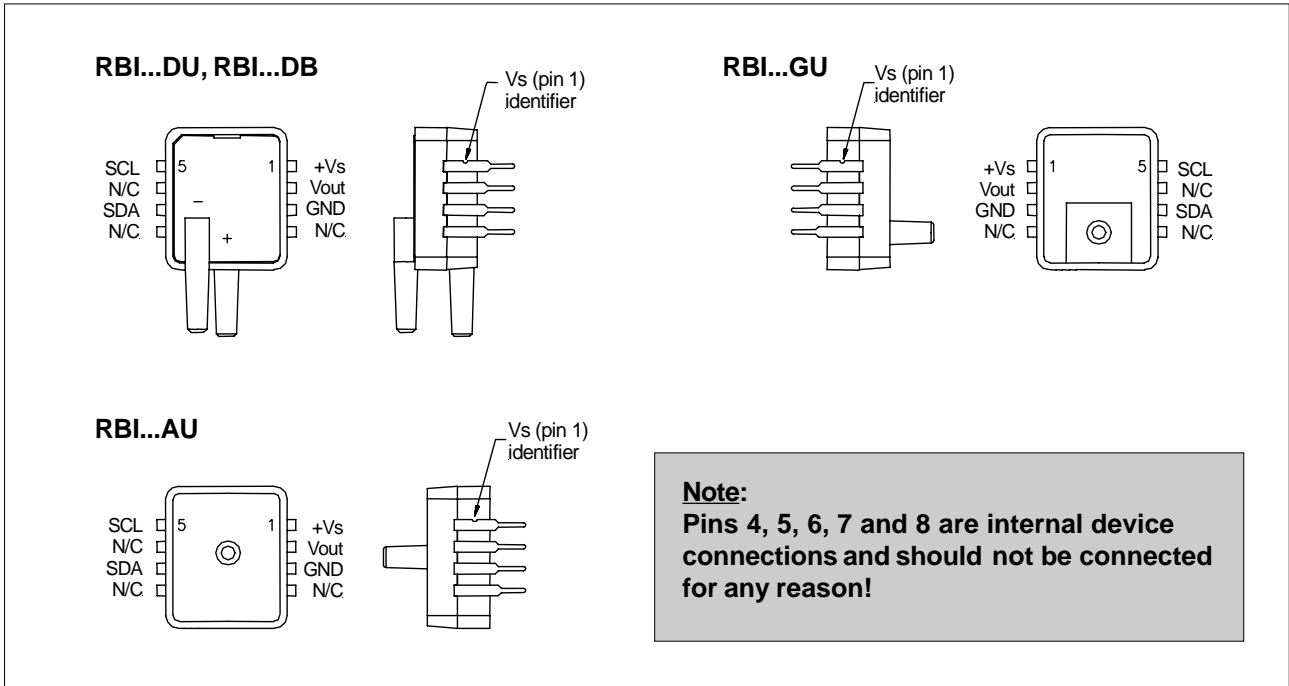

### TOTAL ACCURACY (-20 to +105°C)

For all RBIP... devices

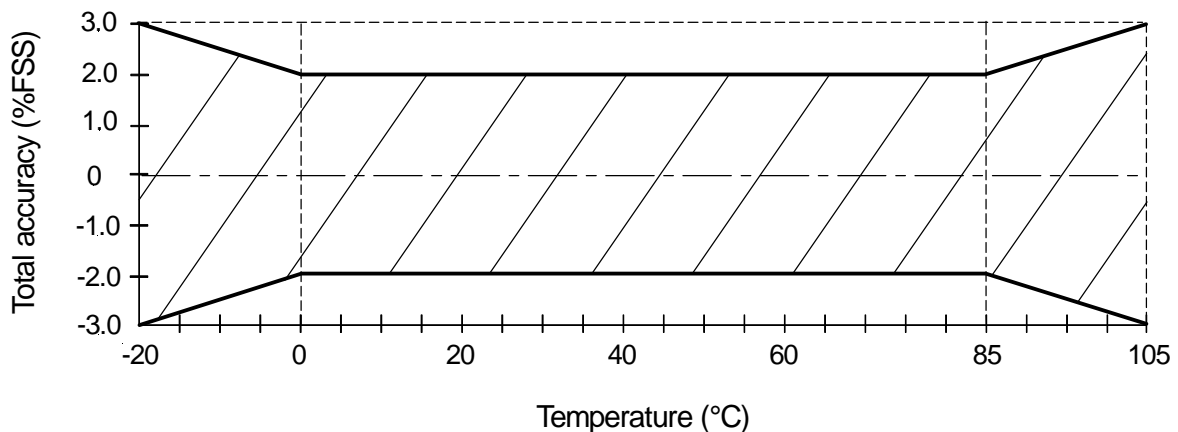





# RBI Series

## Pressure sensors with analog and digital output

### ORDERING INFORMATION - AVAILABLE LISTINGS

**Note:** Preferred listings are highlighted in grey

Pressure range	Absolute (A)	Gage (G)	Differential (D)
<b>Unidirectional (U)</b>			
0...10 inch H <sub>2</sub> O			RBIH010DU
0...1 psi		RBIP001GU	RBIP001DU
0...5 psi		RBIP005GU	RBIP005DU
0...15 psi	RBIP015AU	RBIP015GU	RBIP015DU
0...30 psi	RBIP030AU	RBIP030GU	RBIP030DU
0...100 psi	RBIP100AU	RBIP100GU	RBIP100DU
<b>Bidirectional (B)</b>			
0...±5 inch H <sub>2</sub> O			RBIH005DB
0...±10 inch H <sub>2</sub> O			RBIH010DB
0...±1 psi			RBIP001DB
0...±5 psi			RBIP005DB
0...±15 psi			RBIP015DB
0...±30 psi			RBIP030DB
0...±100 psi			RBIP100DB

#### Sensortech PRO services:

- Extended guarantee period of 2 years
- Improved performance characteristics
- Custom product modifications and adaptations even for small quantities
- Advanced logistics models for supply inventory and short delivery times
- Technical support through application engineers on the phone or at your site
- Fastest possible technical response for design and QA engineers
- ... plus other services on request

Sensortech reserves the right to make changes to any products herein. Sensortech does not assume any liability arising out of the application or use of any product or circuit described herein, neither does it convey any license under its patent rights nor the rights of others.