

# Datasheet

## Fusion USBL Transceivers



### Description

Sonardyne's family of Fusion Ultra-Short BaseLine (USBL) transceivers support the use of modern Wideband signal technology, offering improved noise immunity, increased dynamic range and greater accuracy.

The Type 8021 transceiver offers a hemispherical pattern of acoustic coverage whilst still ensuring rejection of vessel noise. The transceiver allows tracking of targets from below and to the side of the vessel and it is suitable for a wide variety of survey tasks such as towfish tracking and ROV positioning.

The Type 8023 transceiver is optimised to receive signals arriving within a  $\pm 50^\circ$  cone. Any noise generated outside of this area, for example by thrusters, is attenuated further, therefore improving the

signal to noise ratio and so the positioning accuracy.

In practise, this has been proven to allow the accurate positioning of the noisiest vessels. On quieter vessels, it enables even deeper depths to be achieved.

The all new hardware platform on which the Fusion USBL transceivers are based means that the units can be easily upgraded remotely via a serial interface.

They can also be used as Medium Frequency Long Baseline (LBL) transceivers when required. This removes the cost and inconvenience of installing and setting up a separate LBL transceiver when the need arises.

### Key features

- Choice of transceivers depending on operating environment, water depth and vessel
- Incorporates Sonardyne's latest Wideband® signal technology
- Operates as an LBL transceiver for all MF frequency operations
- Remote firmware upgrade via serial interface
- Improved noise immunity and analysis
- Non-Sonardyne frequencies supported

# Specifications

## Fusion USBL Transceivers

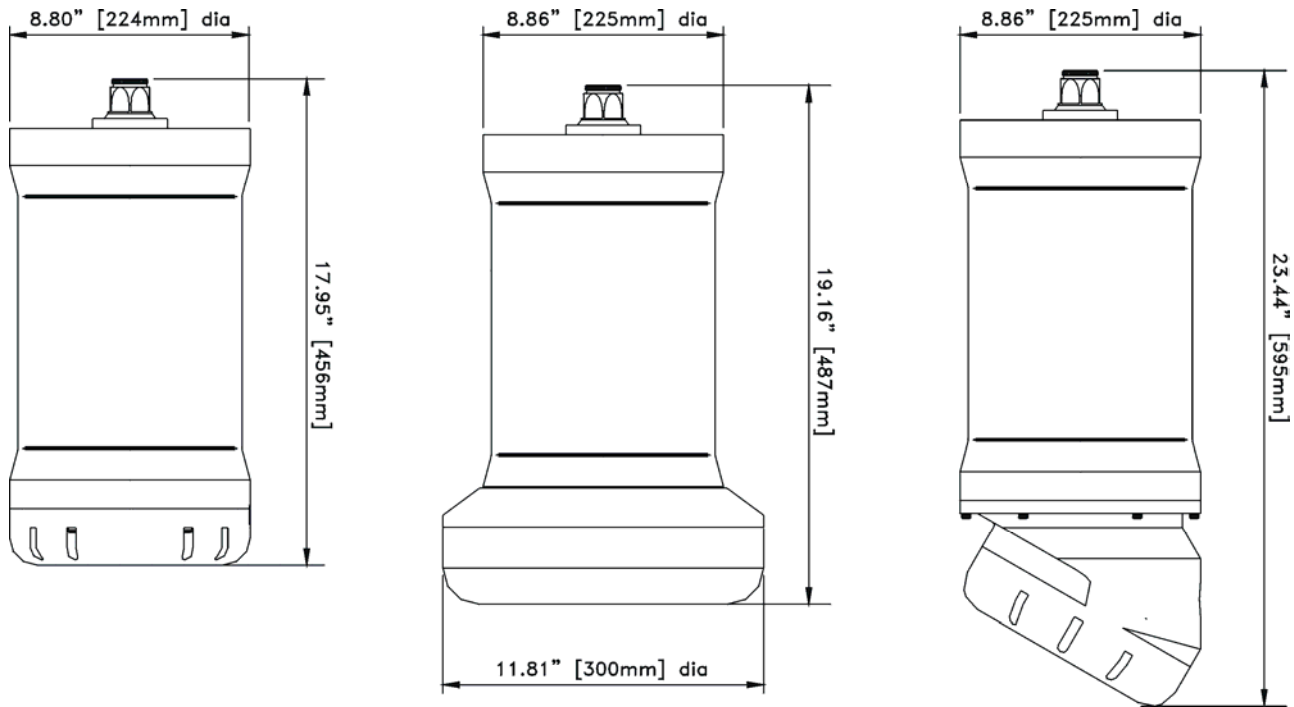

Feature	Type 8021	Type 8023
Operational Frequency	MF (18-36kHz)	MF (18-36kHz)
Transceiver Performance	Operating Range	Up to 7,000 Metres
	Acoustic Cover	± 90°
	Range Accuracy	Better than 0.2 metres
	Positioning Repeatability	All transceivers tested to better than 0.1% of slant range 1 Drms
Electrical	Maximum Power	+48VDC (38V to 50V), can operate on +24VDC (18V to 30V) Typical 15W, Max 50W
		+48VDC (38V to 50V), can operate on +24VDC (18V to 30V) Typical 15W, Max 50W
Communication	RS485, baud rate switchable	RS485, baud rate switchable
Dimensions (LxDia)	456mm (17.95") x 225mm (8.86")	487mm (19.16") x 300mm (11.81")
Weight in Air	28kg	41kg
Weight in Water	13.5kg	20kg
Options	Tilted Array Adaptor	Tilted Array Adaptor
Note	The absolute accuracy of the system is dependent upon the quality of attitude and heading sensors, beacon source level, vessel noise, water depth, mechanical rigidity of the transceiver deployment machine and proper calibration of the total system using CASIUS	