

185-001 (08 Jam Nut) Expanded Beam Fiber Optic Threaded Coupling Jam Nut Receptacle Connector D38999 Style Shell Size 13

185-001 C 08-13-4 N S

Product Series
 Basic Number
 Finish Symbol
 (Table II) Omit for None
 08 = Receptacle Assembly,
 Jam Nut
 Shell Size
 Insert arrangement
 4 = 4 Optical Channels
 2 = 2 Optical Channels
 F = 2 Optical and 2 Electrical
 Alternate Key Position
 (N,A,B,C,D,E) Per MIL-DTL-38999
 Mode
 S = Singlemode
 M = Multimode

TABLE II: FINISH

SYM	FINISH
C	Anodize, Black
M	Electroless Nickel Plate
Z1	Stainless Steel, Passivated
NF	Zinc-Nickel/Olive Drab over Electroless Nickel

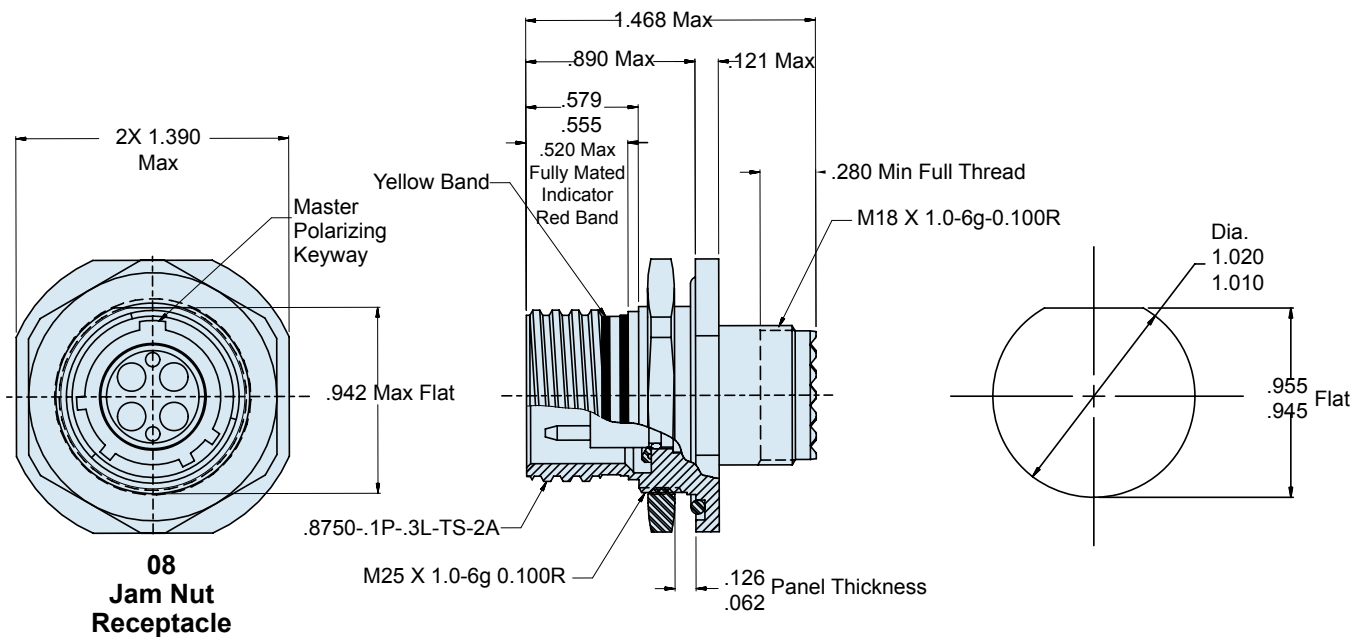

APPLICATION NOTES

1. Assembly identified with Glenair, Inc and P/N, Space Permitting.
2. Glenair 185-001 Connector Features:
 - A. Plug Barrel, Shell, Coupling Nut- AL/BR AB2 or CA104 or DGS1043
 - B. Seal, Gasket- Fluorosilicone Blend
 - C. Thrust Washer & Retaining Ring- Stainless Steel
 - D. Grounding Fingers- Copper Alloy
3. Metric dimensions (mm) are in parentheses.

**PART SUPPLIED ONLY AS
TERMINATED ASSEMBLY**

**CONSULT FACTORY
FOR CABLE DESIGN**