

## Features

- High Dynamic Range: 42dB Typical
- Flat Attenuation vs. Frequency
- High P1dB Compression
- Operates on a Single +5V Supply:
- 50 Ohm Nominal Impedance
- Lead-Free SOW-16 Package
- 100% Matte Tin Plating over Copper
- Halogen-Free "Green" Mold Compound
- 260°C Reflow Compatible
- RoHS\* Compliant Version of AT10-0019

## Description

M/A-COM's MAAV-007088-000100 is a Voltage Controlled PIN diode based  $\pi$  attenuator packaged in a low cost, 16 lead wide body plastic SMT package. The PIN diode design makes this part well suited for applications where low distortion or high linear operating power levels are required. These attenuators are ideal for gain control in multi-channel digital communications systems.

## Functional Schematic

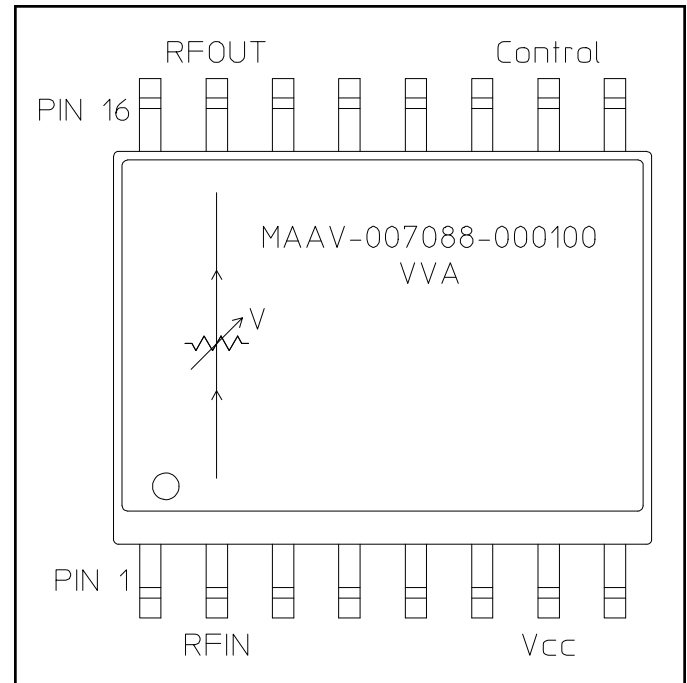

## Ordering Information

Part Number	Package
MAAV-007088-000100	Bulk Packaging
MAAV-007088-0001TR	1000 piece reel
MAAV-007088-0001TB	Sample Test Board

Note: Reference Application Note M513 for reel size information.

## Pin Configuration

Pin No.	Function	Pin No.	Function
1	GND	9	GND
2	RF IN	10	V CONTROL
3	GND	11	GND
4	GND	12	GND
5	GND	13	GND
6	GND	14	GND
7	V SUPPLY	15	RF OUT
8	GND	16	GND

\* Restrictions on Hazardous Substances, European Union Directive 2002/95/EC.

**Electrical Specifications:  $T_A = 25^\circ\text{C}$ ,  $Z_0 = 50\Omega^1$**

Parameter	Test Conditions	Frequency	Units	Min	Typ	Max
Insertion Loss	Vcont.: +10 V	50 - 1000 MHz	dB	—	2.4	2.8
Dynamic Range	Vcont.: 0 V	50 - 1000 MHz	dB	33	42	—
Attenuation Flatness	Attenuation: 0 to 20 dB Attenuation: 20 to 30 dB	50 - 1000 MHz	dB	—	1.0	1.5
		50 - 1000 MHz	dB	—	1.5	2.0
VSWR	Vcont.: 0 - 10V	50 - 1000 MHz	Ratio	—	1.7:1	2.1:1
Trise, Tfall Ton, Toff Transients	10%/90%, 90%/10% 50% Cntl to 90%/10% RF In-band	—	$\mu\text{s}$	—	10	20
		—	$\mu\text{s}$	—	15	25
		—	mV	—	150	250
1 dB Compression	Vcont.: 0 - 10V	100 MHz	dBm	10	13	—
		500 MHz	dBm	17	20	—
		1000 MHz	dBm	21	24	—
Input IP <sub>3</sub>	Vcont.: 0 - 10V Two-tone inputs up to +10 dBm	100 MHz	dBm	24	27	—
		1000 MHz	dBm	34	37	—
V <sub>CC</sub>	—	—	V	+4.75	+5.0	+5.25
I <sub>CC</sub>	V <sub>CC</sub> = 5.25 V	DC	mA	—	2	2.5
Control Current	—	DC	mA	—	2.7	3.5

1. Unit requires external .01  $\mu\text{F}$  DC Blocks on RF lines.

**Absolute Maximum Ratings <sup>2,3</sup>**

Parameter	Absolute Maximum
Max. Input Power 50 - 500 MHz 500 - 1000 MHz	+24 dBm +30 dBm
Voltages V <sub>CC</sub> Control Voltage	-1 V to +7.0 V -1 V to +15 V
Operating Temperature	-40°C to +85°C
Storage Temperature	-65°C to +125°C

- Exceeding any one or combination of these limits may cause permanent damage to this device.
- M/A-COM does not recommend sustained operation near these survivability limits.

**Handling Procedures**

Please observe the following precautions to avoid damage:

**Static Sensitivity**

Gallium Arsenide Integrated Circuits are sensitive to electrostatic discharge (ESD) and can be damaged by static electricity. Proper ESD control techniques should be used when handling these devices.

**Pad Layout**

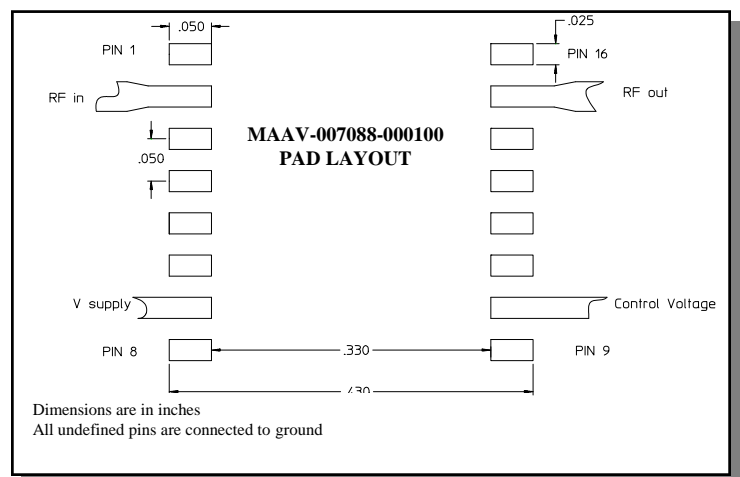

## Typical Performance Curves

Attenuation vs. Frequency @ Control Voltage = 0V

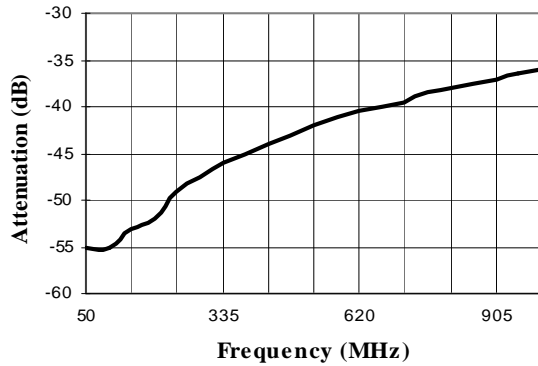

Attenuation vs. Control Voltage @ 500 MHz

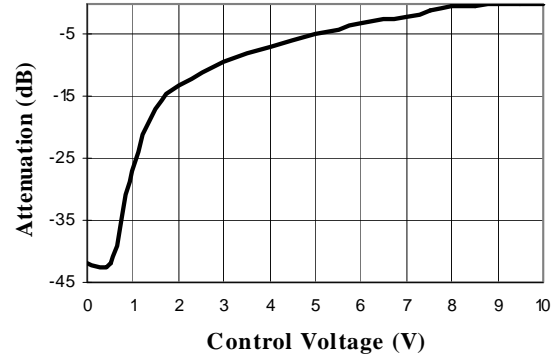

Insertion Loss vs. Frequency @ Control Voltage = 10V

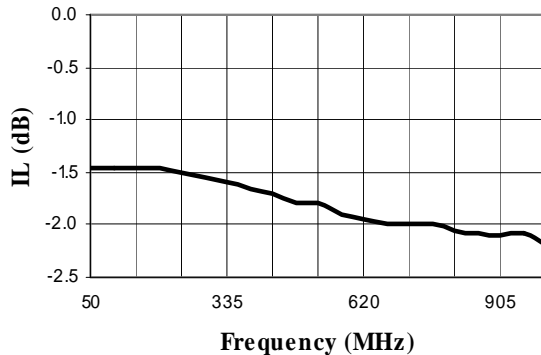

**Lead-Free, SOW-16†**

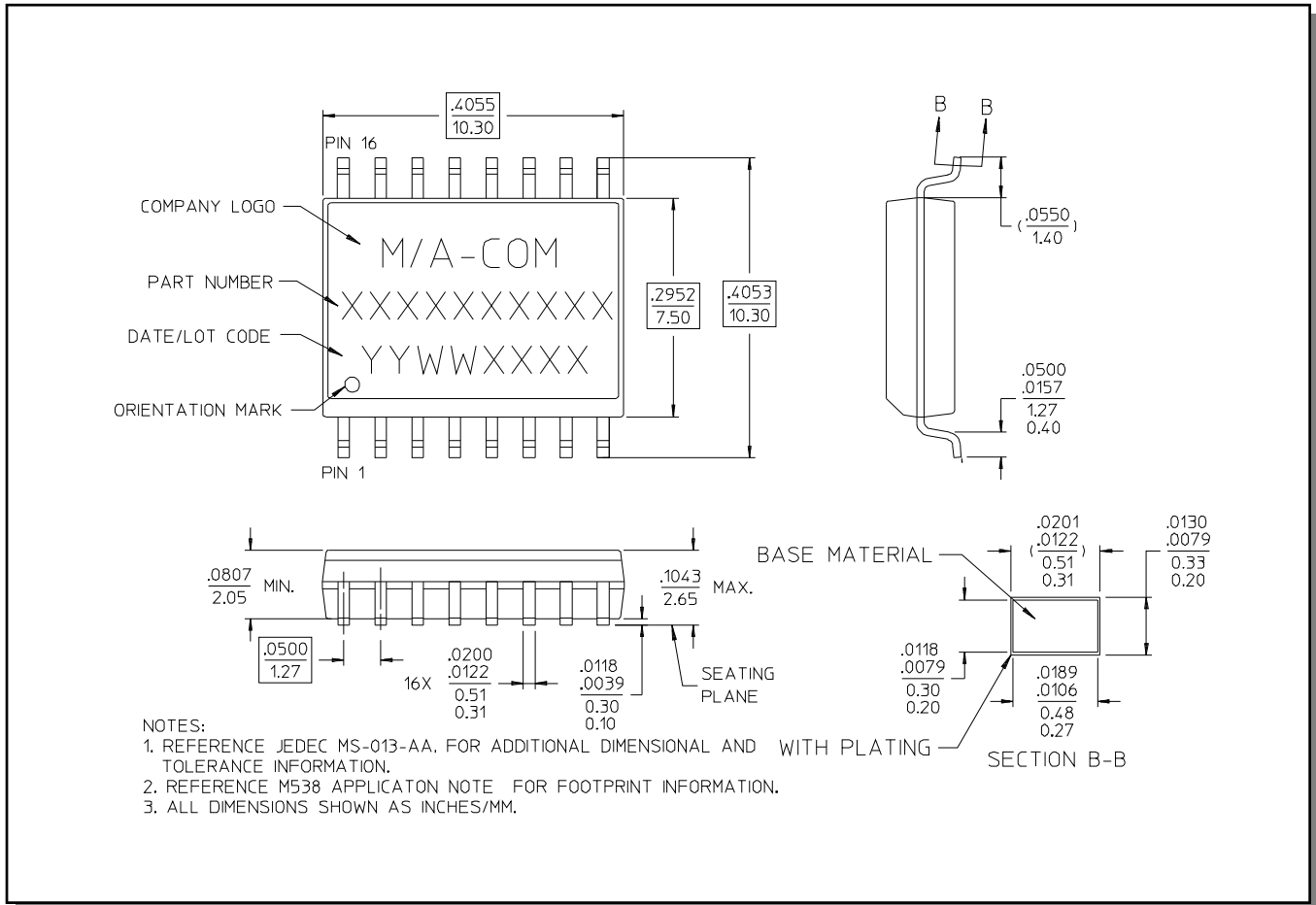

† Reference Application Note M538 for lead-free solder reflow recommendations.