

## Features

- Input IP3: +31 dBm Min (Full Attenuation Range)
- Input IP3 is **15 -20 dB** Better than GaAs
- Linear Operation: +20 dBm Typ.
- Plastic, 28 Lead, 6 mm CSP, SMT Package
- 35 dB Dynamic Range (With 30 mA Bias Current)
- Single Control Voltage
- 50 ohm Impedance
- Linear Driver, MADR-007098-000100, Available
- Test Boards are Available
- Tape and Reel Packaging Available
- 100% Matte Tin Plating over Copper
- Halogen-Free "Green" Mold Compound
- 260°C Reflow Compatible
- RoHS\* Compliant Version of MAAVCC0002

## Description

M/A-COM's MAAV-007091-000100 is a PIN diode based voltage variable attenuator. This device is in a 6mm square, 28 lead, plastic CSP package, suitable for surface mounting on PCBs. These attenuators have linear operating power and input intercept point levels 15 - 20 dB better than GaAs FET MMIC voltage variable attenuators. They are ideally suited for use where low distortion, high linear operating power and high dynamic range are required. These devices are optimized for the PCS and UMTS frequency bands, but exhibit excellent performance and repeatability over the entire specified frequency band. The MAAV-007091-000100 is ideally suited for wireless communications systems.

## Ordering Information

Part Number	Package
MAAV-007091-000100	Bulk Packaging
MAAV-007091-0001TR	1000 piece reel
MAAV-007091-0001TB	Sample Test Board

Note: Reference Application Note M513 for reel size information.

\* Restrictions on Hazardous Substances, European Union Directive 2002/95/EC.

## Functional Schematic

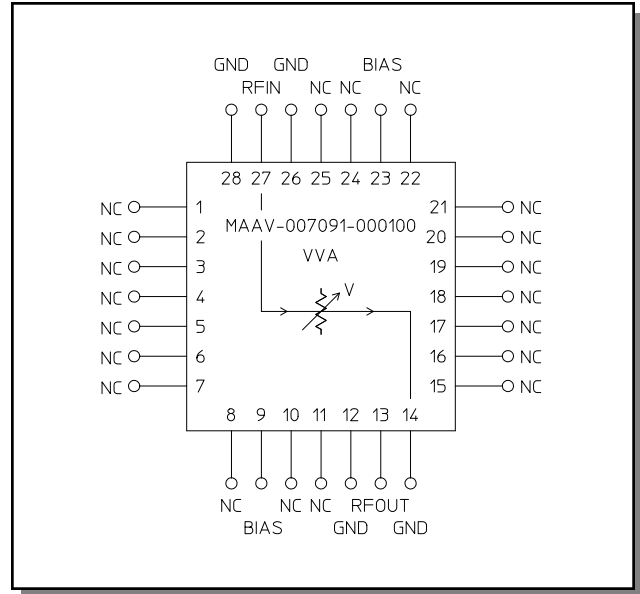

## Pin Configuration<sup>2,3</sup>

Pin #	Function	Pin #	Function
1	NC	15	NC
2	NC	16	NC
3	NC	17	NC
4	NC	18	NC
5	NC	19	NC
6	NC	20	NC
7	NC	21	NC
8	NC	22	NC
9	BIAS <sup>1</sup>	23	BIAS <sup>1</sup>
10	NC	24	NC
11	NC	25	NC
12	GND	26	GND
13	RFOUT	27	RFIN
14	GND	28	GND

1. Bias current may be applied to Pin 9 or 23. However, the unused pin must be isolated.
2. The exposed pad centered on the package bottom must be connected to RF and DC ground. (For PQFN packages)
3. It is preferable to ground all "NC" pins, except for the unused bias pin, which must be left open.

**ADVANCED:** Data Sheets contain information regarding a product M/A-COM Technology Solutions is considering for development. Performance is based on target specifications, simulated results, and/or prototype measurements. Commitment to develop is not guaranteed.  
**PRELIMINARY:** Data Sheets contain information regarding a product M/A-COM Technology Solutions has under development. Performance is based on engineering tests. Specifications are typical. Mechanical outline has been fixed. Engineering samples and/or test data may be available. Commitment to produce in volume is not guaranteed.

• **North America** Tel: 800.366.2266 / Fax: 978.366.2266  
 • **Europe** Tel: 44.1908.574.200 / Fax: 44.1908.574.300  
 • **Asia/Pacific** Tel: 81.44.844.8296 / Fax: 81.44.844.8298  
 Visit [www.macomtech.com](http://www.macomtech.com) for additional data sheets and product information.

M/A-COM Technology Solutions Inc. and its affiliates reserve the right to make changes to the product(s) or information contained herein without notice.

### Electrical Specifications: $T_A = 25^\circ\text{C}$

Parameter	Test Conditions	Frequency	Units	Min.	Typ.	Max.
Insertion Loss	0 volts	1700-2200 MHz	dB	—	2.9	4.0
Attenuation (Above Loss)	10 mA bias current	1700-2200 MHz	dB	30	33	—
Attenuation Flatness	0 to 30 dB attenuation	1700-2200 MHz	dB	—	1.0	2.0
VSWR	0 to 30 dB attenuation	1700-2200 MHz	Ratio	—	2:1	2.2:1
Switching Speed	50% Control to 90%/10% RF	1700-2200 MHz	$\mu\text{s}$	—	—	3.0
Linear Operation	—	1700-2200 MHz	dBm	—	+20	—
Input $IP_3$	Two-tone inputs up to +10 dBm	1700-2200 MHz	dBm	+31	—	—
P1 dB	Full Attenuation Range	1700-2200 MHz	dBm	—	+23	—
$I_{\text{Control}}$	—	1700-2200 MHz	mA	—	—	30

### Absolute Maximum Ratings <sup>4</sup>

Parameter	Absolute Maximum
Max. Input Power 1700 - 2200 MHz	+27 dBm
Operating Temperature	-40°C to +85°C
Storage Temperature	-65°C to +125°C

4. Exceeding any one or combination of these limits may cause permanent damage to this device.

### Handling Procedures

Please observe the following precautions to avoid damage:

### Static Sensitivity

Gallium Arsenide Integrated Circuits are sensitive to electrostatic discharge (ESD) and can be damaged by static electricity. Proper ESD control techniques should be used when handling these devices.

### Recommended PCB Layout

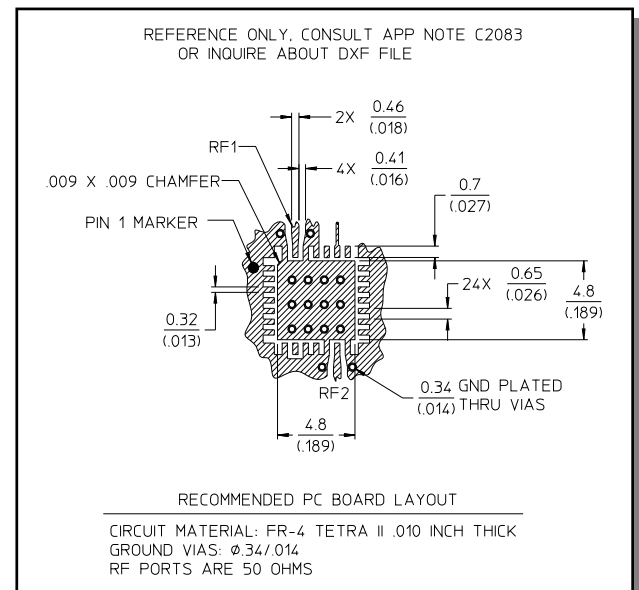

## Typical Performance Curves

Insertion Loss

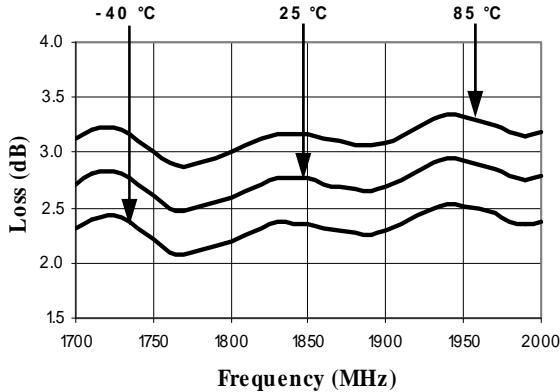

## Typical Performance Curves (beyond 2GHz)

Insertion Loss @ 25°C

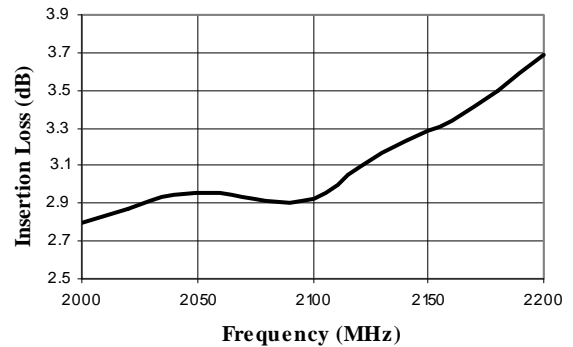

Attenuation Flatness @ +25°C

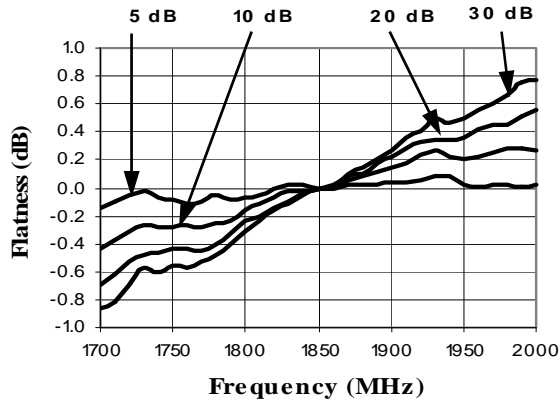

Attenuation Flatness @ 25°C

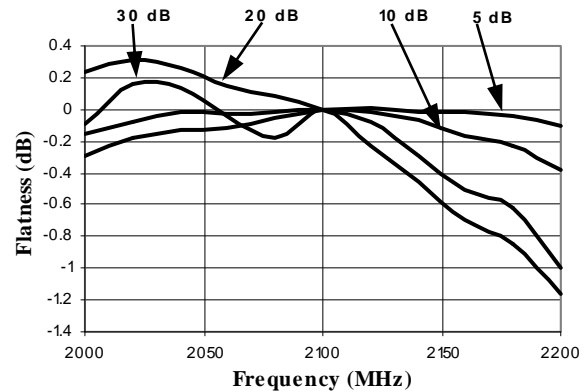

Typical VSWR @ +25°C

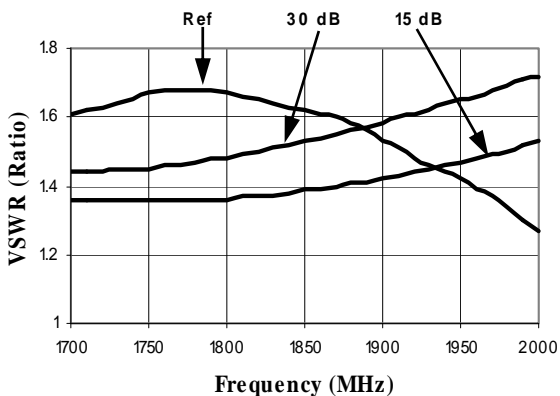

Typical VSWR @ +25°C

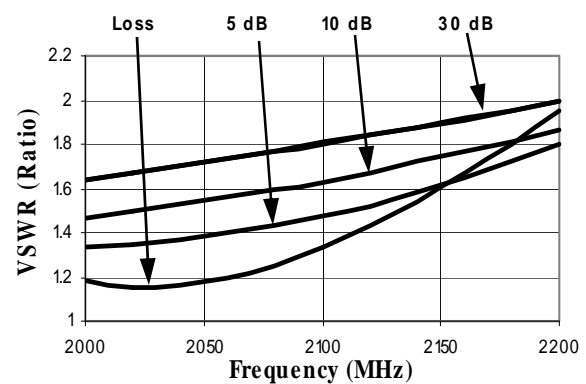

## Voltage Variable Absorptive Attenuator, 1700 - 2200 MHz

Rev. V3

### Attenuation vs. Bias Current, Frequency = 2000 MHz

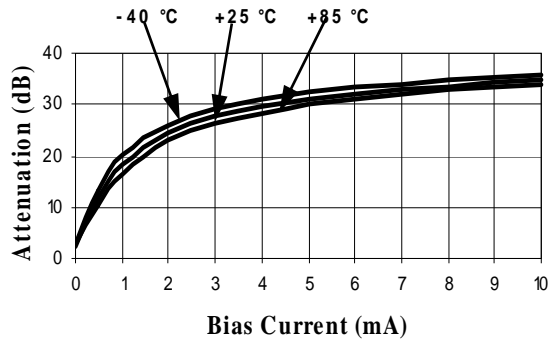

### CSP-8, 28 Lead, 6mm

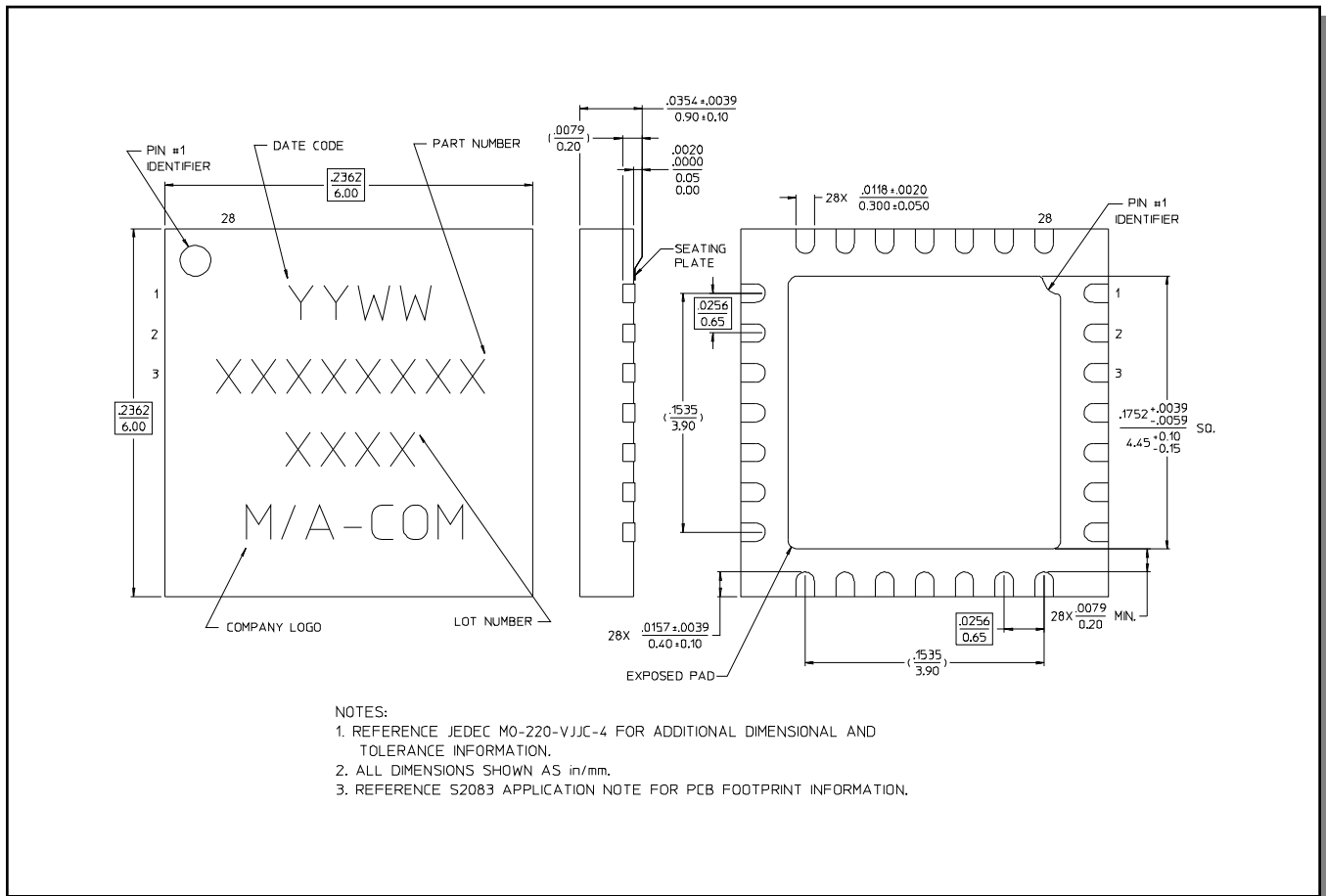

Package outline conforms to JEDEC standard MO-220B.