

SHARP

LQ181E1LW31

TFT-LCD Module

(Model Number: LQ181E1LW31)

Specifications

Spec No.: LD-13Z04

Dated: May 29, 2002

PREPARED BY : DATE	<h1>SHARP</h1> <p>AVC LCD DEVELOPMENT GROUP SHARP CORPORATION</p> <h2>SPECIFICATION</h2>	SPEC No. LD-13Z04
APPROVED BY : DATE		FILE No.
		ISSUE : May.27.2002
		PAGE : 22 pages
		APPLICABLE GROUP AVC Liquid Crystal Display Group

DEVICE SPECIFICATION

TFT-LCD Module

MODEL No.

LQ181E1LW31

CUSTOMER'S APPROVAL

DATE _____

BY _____

PRESENTED

BY _____

M.TAKEDA
 Development General Manager
 Development Engineering Department 2
 AVC LIQUID CRYSTAL DISPLAY Division
 AVC LIQUID CRYSTAL DISPLAY GROUP
 SHARP CORPORATION

1. Application

This specification applies to the color 18.1 SXGA TFT-LCD module LQ181E1LW31.

- These specification sheets are the proprietary product of SHARP CORPORATION("SHARP) and include materials protected under copyright of SHARP. Do not reproduce or cause any third party to reproduce them in any form or by any means, electronic or mechanical, for any purpose, in whole or in part, without the express written permission of SHARP.
- The device listed in these specification sheets was designed and manufactured for use in OA equipment.
- In case of using the device for applications such as control and safety equipment for transportation(aircraft, trains, automobiles, etc.), rescue and security equipment and various safety related equipment which require higher reliability and safety, take into consideration that appropriate measures such as fail-safe functions and redundant system design should be taken.
- Do not use the device for equipment that requires an extreme level of reliability, such as aerospace applications, telecommunication equipment(trunk lines), nuclear power control equipment and medical or other equipment for life support.
- SHARP assumes no responsibility for any damage resulting from the use of the device which does not comply with the instructions and the precautions specified in these specification sheets.
- Contact and consult with a SHARP sales representative for any questions about this device.

2. Overview

This module is a color active matrix LCD module incorporating amorphous silicon TFT (Thin Film Transistor). It is composed of a color TFT-LCD panel, driver ICs, control circuit, power supply circuit and a back light unit. Graphics and texts can be displayed on a 1280×3×1024 dots panel with about 16 million colors (8 bit) by using LVDS (Low Voltage Differential Signaling) to interface and supplying +12 DC supply voltages for TFT-LCD panel driving and supply voltage for backlight.

It is a wide viewing-angle-module using SHARP original technology.

Backlight-driving DC/AC inverter is not built in this module.

3. Mechanical Specifications

Parameter	Specifications	Unit
Display size	46 (Diagonal)	cm
	18.1 (Diagonal)	Inch
Active area	359.0 (H)×287.2 (V)	mm
Pixel format	1280 (H)×1024 (V)	Pixel
	(1 pixel=R+G+B dots)	
Pixel pitch	0.2805 (H) × 0.2805 (V)	mm
Pixel configuration	R,G,B vertical stripe	
Display mode	Normally Black	
Unit outline dimensions *1	389 (W)×317.2 (H)×27.5(D)	mm
Mass	MAX 3.5	kg
Surface treatment	Anti-glare and hard-coating 2H	

*1.Note: excluding back light cables.

The thickness of module (D) doesn't contain the projection.

Outline dimensions are shown in Fig.1.

4. Input Terminals

4-1. TFT-LCD panel driving

CN1 (Interface signals and +12VDC power supply)

Using connector : FI-SE30P-HF (Japan Aviation Electronics Ind.,Ltd.)

Mating connector : FI-S30S (Japan Aviation Electronics Ind.,Ltd.)

Pin No.	Symbol	Function	Remark
1	Vcc	+12V Power Supply	
2	Vcc	+12V Power Supply	
3	Vcc	+12V Power Supply	
4	GND	GND	
5	GND	GND	
6	GND	GND	
7	SELLVDS	Select LVDS data order 【Note1】	3.3V C-MOS Pull Up
8	NC	NC	
9	GND	GND	
10	RxBIN3+	Positive (+) LVDS differential data input (B port)	LVDS
11	RxBIN3-	Negative (-) LVDS differential data input (B port)	LVDS
12	RxBCLKIN+	Positive (+) LVDS differential clock input (B port)	LVDS
13	RxBCLKIN-	Negative (-) LVDS differential clock input (B port)	LVDS
14	RxBIN2+	Positive (+) LVDS differential data input (B port)	LVDS
15	RxBIN2-	Negative (-) LVDS differential data input (B port)	LVDS
16	RxBIN1+	Positive (+) LVDS differential data input (B port)	LVDS
17	RxBIN1-	Negative (-) LVDS differential data input (B port)	LVDS
18	RxBIN0+	Positive (+) LVDS differential data input (B port)	LVDS
19	RxBIN0-	Negative (-) LVDS differential data input (B port)	LVDS
20	RxAIN3+	Positive (+) LVDS differential data input (A port)	LVDS
21	RxAIN3-	Negative (-) LVDS differential data input (A port)	LVDS
22	RxACLKIN+	Positive (+) LVDS differential clock input (A port)	LVDS
23	RxACLKIN-	Negative (-) LVDS differential clock input (A port)	LVDS
24	RxAIN2+	Positive (+) LVDS differential data input (A port)	LVDS
25	RxAIN2-	Negative (-) LVDS differential data input (A port)	LVDS
26	RxAIN1+	Positive (+) LVDS differential data input (A port)	LVDS
27	RxAIN1-	Negative (-) LVDS differential data input (A port)	LVDS
28	RxAIN0+	Positive (+) LVDS differential data input (A port)	LVDS
29	RxAIN0-	Negative (-) LVDS differential data input (A port)	LVDS
30	GND	GND	

【Note1】 SELLVDS(Thine:THC63LVDM83A)

Transmitter		SELLVDS	
Pin No	Data	=L(GND)	=H(3.3V) or Open
51	TA0	R0(LSB)	R2
52	TA1	R1	R3
54	TA2	R2	R4
55	TA3	R3	R5
56	TA4	R4	R6
3	TA5	R5	R7(MSB)
4	TA6	G0(LSB)	G2
6	TB0	G1	G3
7	TB1	G2	G4
11	TB2	G3	G5
12	TB3	G4	G6
14	TB4	G5	G7(MSB)
15	TB5	B0(LSB)	B2
19	TB6	B1	B3
20	TC0	B2	B4
22	TC1	B3	B5
23	TC2	B4	B6
24	TC3	B5	B7(MSB)
27	TC4	NC	NC
28	TC5	(RSV1)	(RSV1)
30	TC6	DE	DE
50	TD0	R6	R0(LSB)
2	TD1	R7(MSB)	R1
8	TD2	G6	G0(LSB)
10	TD3	G7(MSB)	G1
16	TD4	B6	B0(LSB)
18	TD5	B7(MSB)	B1
25	TD6	(NA)	(NA)

SELLVDS= Low (GND)

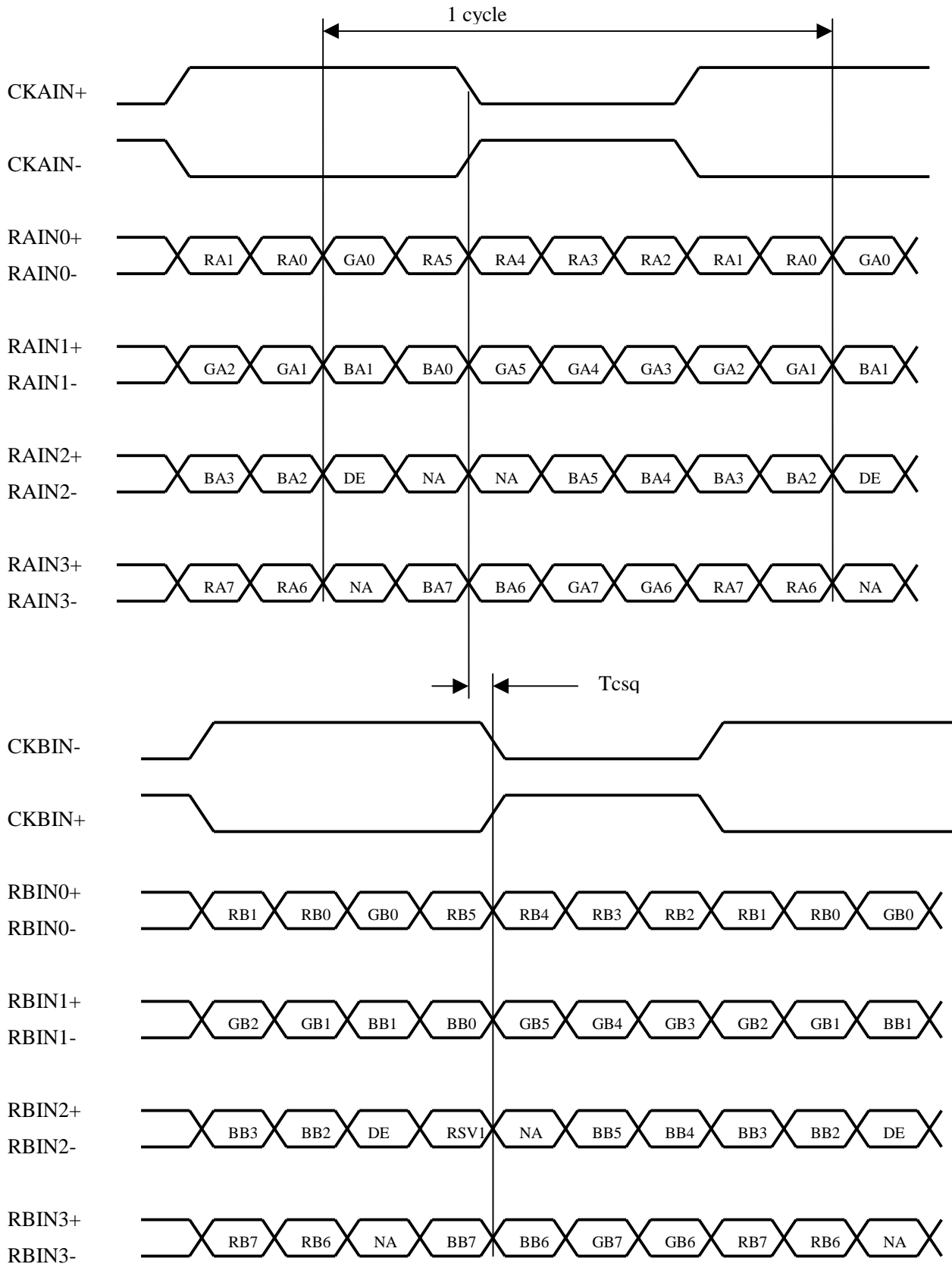

DE: Display Enable

RSV1: Reserve (Fixed GND)

NA: Not Available

SELLVDS= High(3.3V) or Open

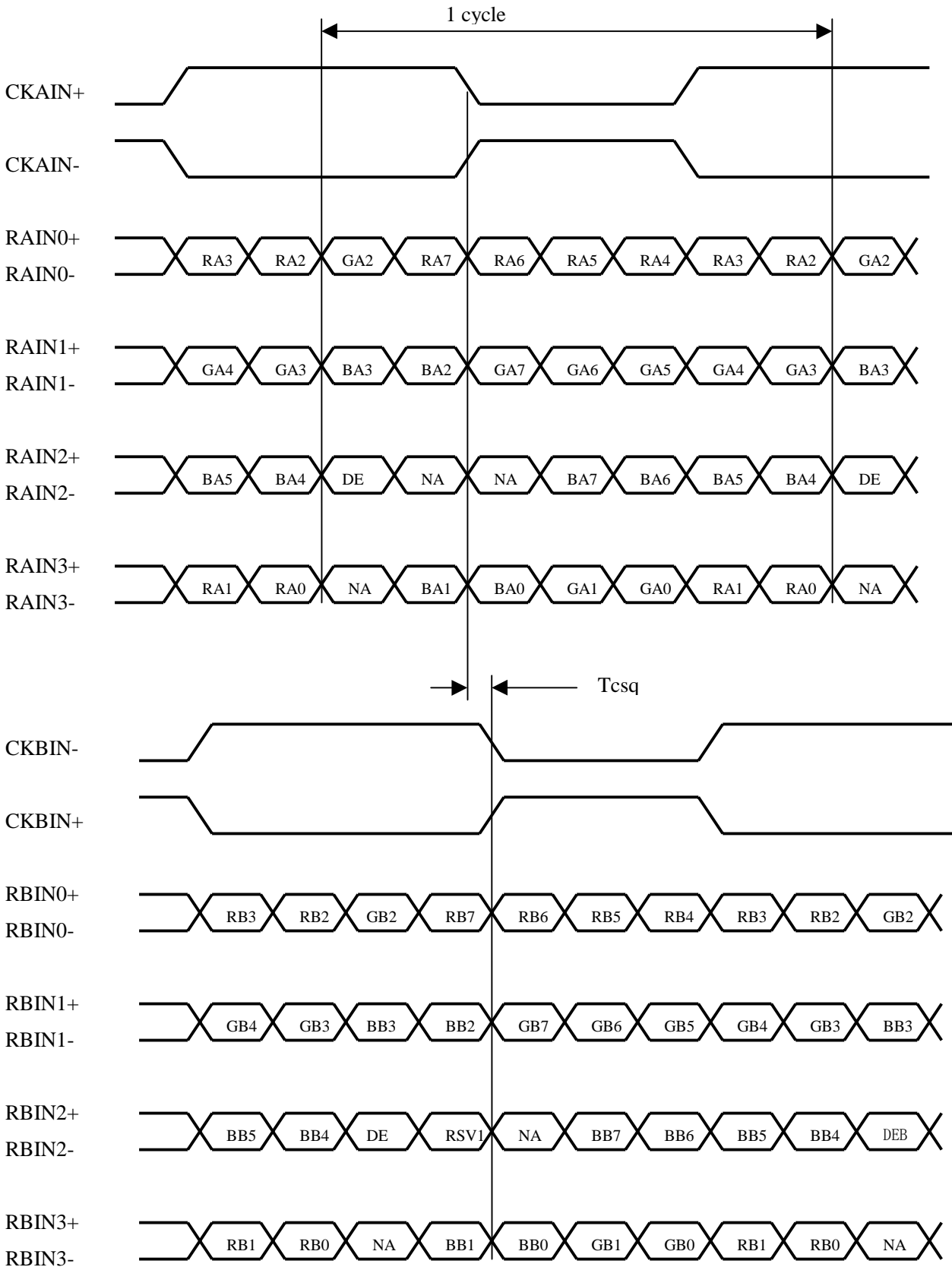

DE: Display Enable

RSV1: Reserve (Fixed GND)

NA: Not Available

4-2 Interface block diagram

Using receiver : Contained in a control IC.

Corresponding Transmitter : THC63LVDM83A(THine electronics),DS90C383,DS90C383A(National semiconductor)

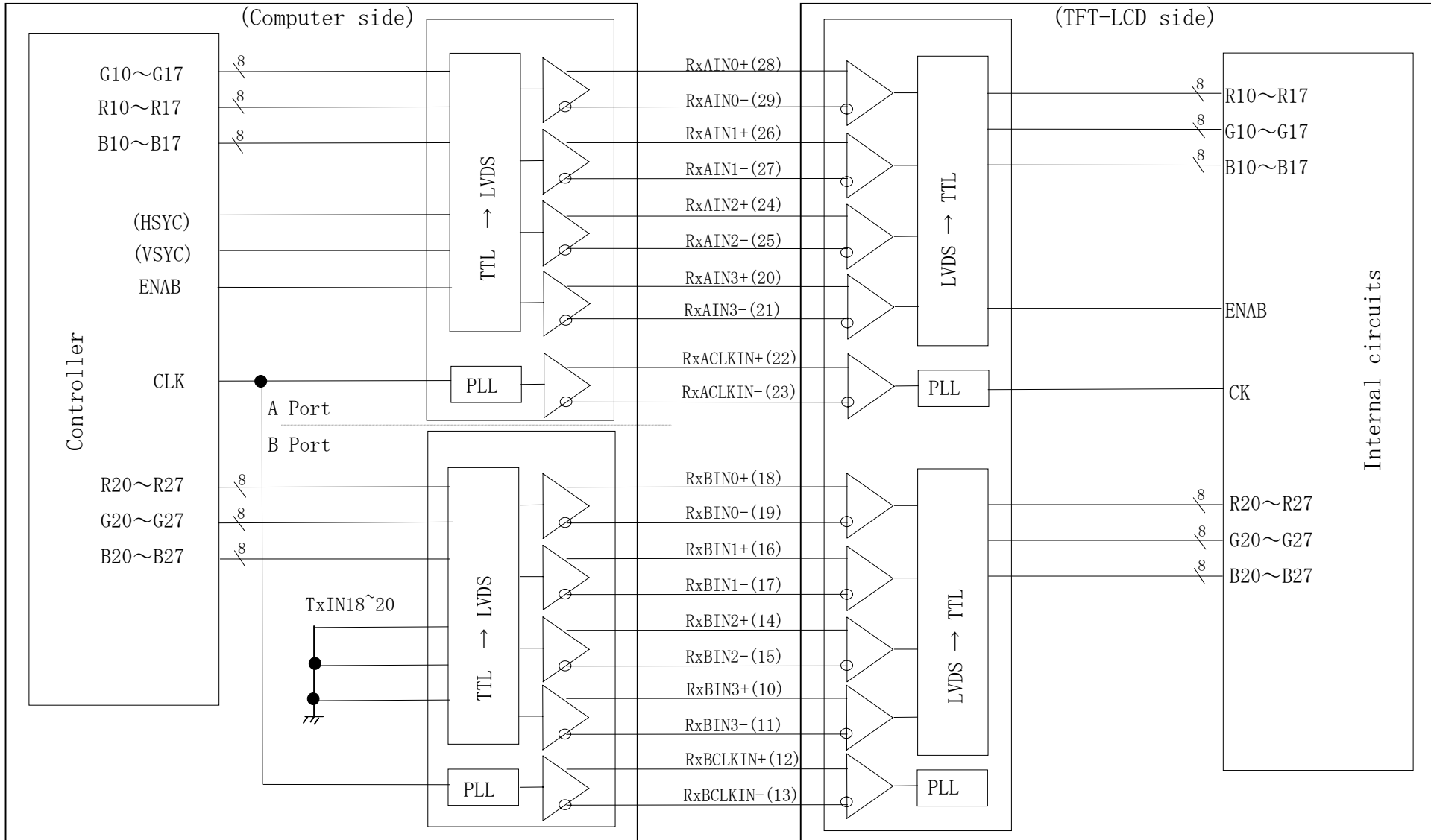

Fig.2 Interface block diagram

4-2. Back light driving

CN 2, 3

The module-side connector : BHSR-02VS-1 (JST)

The user-side connector : SM02B-BHSS-1-TB (JST)

Pin no.	Symbol	I/O	Function
1	V _{HIGH}	I	Power supply for lamp (High voltage side)
2	V _{LOW}	I	Power supply for lamp (Low voltage side)

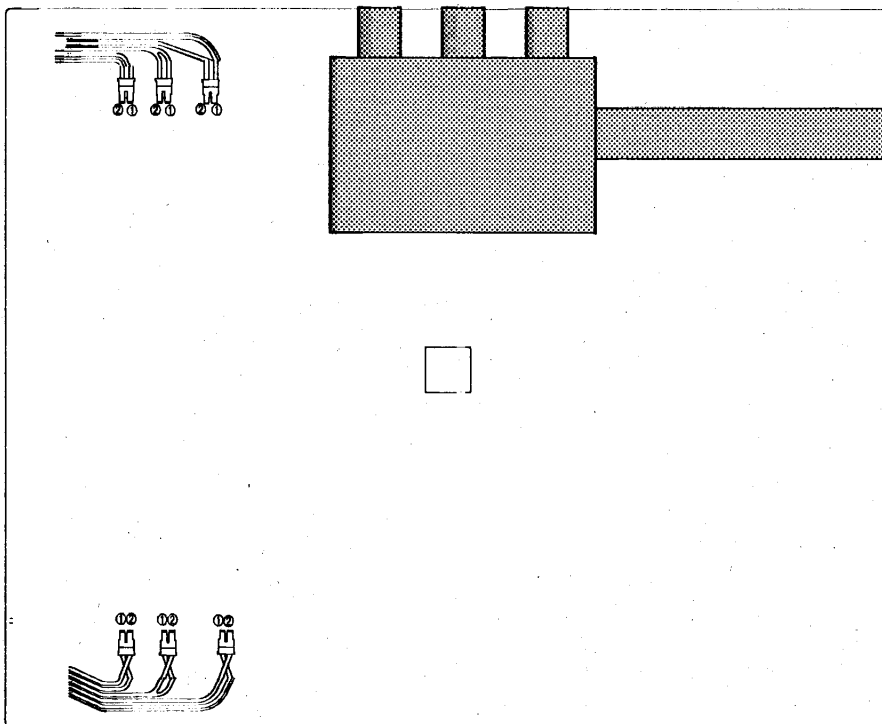

5. Absolute Maximum Ratings

5-1. Module

Parameter	Symbol	Condition	Ratings	Unit	Remark
Storage temperature	Tstg	-	-25 ~ +60	°C	【Note1】
Operating temperature (Ambient)	Topa	-	0 ~ +50	°C	

【Note1】 Humidity : 95%RH Max. (Ta ≤ 40°C)

Maximum wet-bulb temperature at 39°C or less. (Ta > 40°C)

No condensation.

5-2. TFT-LCD panel driving

Parameter	Symbol	Condition	Ratings	Unit	Remark
+12.0V supply voltage	Vcc	Ta=25°C	0 ~ +14.0	V	

6. Electrical Characteristics

6-1. TFT-LCD panel driving

Ta=25°C

Parameter		Symbol	Min.	Typ.	Max.	Unit	Remark
Vcc	Supply voltage	Vcc	+11.4	+12.0	+12.6	V	【Note1】
	Current dissipation	Icc	-	350	600	mA	【Note2】
Permissive input ripple voltage		V _{RF}	-	-	100	mVp-p	
Input current (Low)		I _{IL}	-	-	10	μA	V _I =GND
Input current (High)		I _{IH}	-	-	10	μA	V _I =Vcc

【Note1】

1) On-off sequences of Vcc and data

- 0 < t1 ≤ 60ms
- 0 < t2 ≤ 10ms
- 0 ≤ t3 ≤ 1s
- t4 ≥ 100ms

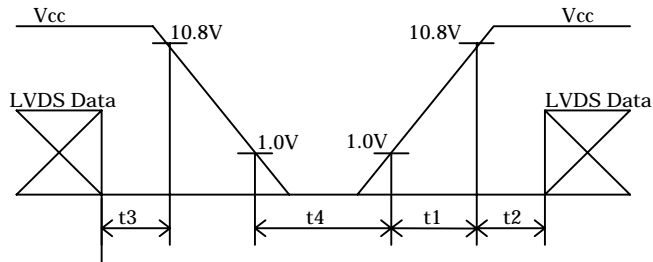

2) Dip conditions for supply voltage

V_{min}=11.4V, V_t=9.6V

- i) V_t ≤ Vcc < V_{min}
td ≤ 20ms
- ii) Vcc < V_t

This case is described below *1.

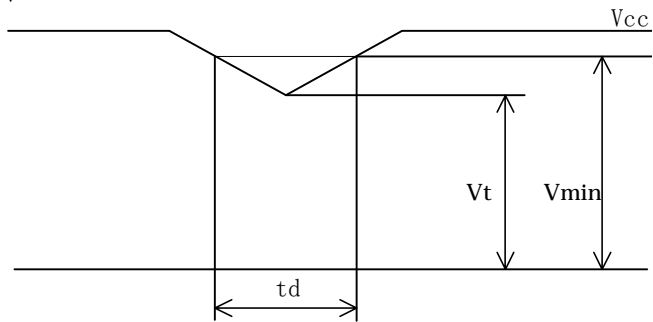

*1 The LCD module shuts down when Vcc < V_t

It should also follow the 1) on-off sequence of Vcc and data.

【Note2】

1) Typical current situation : 16-gray-bar pattern

Vcc=+12.0V

Gray scale : GS(16N) N=0 ~ 15

The explanation of each gray scale ,GS(16n), is described below section 8.

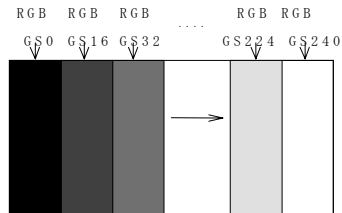

2) Maximum current situation :

The dots described the following figure(left) are displayed the gray scale described the following figure(right).

```

R G B R G B
R G B R G B
R G B R G B
R G B R G B
R G B R G B
R G B R G B
    
```

```

O S O S O S
O S O S O S
S O S O S O
S O S O S O
O S O S O S
O S O S O S
    
```

O=V0 gray scale
S=V255 gray scale

The voltage correspond one of the 256 gray scale.

6-2. Back light driving

The back light system is an edge-lighting type with six CCFTs (Cold Cathode Fluorescent Tube). The characteristics of the lamp are shown in the following table. The value mentioned below is at the case of one CCFT.

CCFT Model Name : MBT26B19RX376NRBU(HARISON TOSHIBA LIGHTING Corp.)

Parameter	Symbol	Min.	Typ.	Max.	Unit	Remark
Lamp current range	I_L	2.5	6.0	7.0	mArms	【Note1】
Lamp voltage	V_L	-	715	-	Vrms	Ta=25°C
Lamp power consumption	P_L	-	4.3	-	W	【Note2】
Lamp frequency	F_L	35	60	70	KHz	【Note3】
Kick-off voltage	V_s	-	-	1300	Vrms	Ta=25°C 【Note4】
		-	-	1500	Vrms	Ta=0°C 【Note4】
Lamp life time	T_L	50000	-	-	hour	【Note5】

【Note1】 A lamp can be light in the range of lamp current shown above.35~70

Maximum rating for current is measured by high frequency current measurement equipment connected to V_{LOW} at circuit showed below. (Note : To keep enough kick-off voltage and necessary steady voltage for CCFT.)

Lamp frequency: 35~70KHz Ambient temperature: 0 ~ 50°C

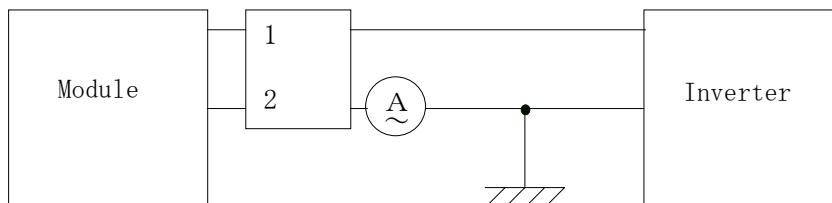

【Note2】 Referential data per one CCFT by calculation ($I_L \times V_L$).

The data don't include loss at inverter.

【Note3】 Lamp frequency may produce interference with horizontal synchronous frequency, and this may cause beat on the display. Therefore lamp frequency shall be detached as much as possible from the horizontal synchronous frequency and from the harmonics of horizontal synchronous to avoid interference.

【Note4】 Kick-off voltage value is described as the index in the state of lamp only.

The kick-off voltage is estimated to be risen up as approx. +200V in the state of module only, and the further rise up can be seen according to the assembling status of user cabinet.

Please set the kick-off voltage of inverter to avoid the lighting failures in the state of operation. Please design the inverter so that its open output voltage can be connected for more than 1 second to startup. Otherwise, the lamp may not be turned on. But, please set as 100ms when the ambient luminance around the lamp is more than 1lux.

【Note5】 Lamp life time is defined as the time when either 1 or 2 occurs in the continuous operation under the condition of Ta=25°C and $I_L=6.0$ mArms.

1. Brightness becomes 50% of the original value under standard condition.
2. Kick-off voltage at Ta=0°C exceeds maximum value, 1500 Vrms.

《Note》 The performance of the back light, for example life time or brightness, is much influenced by the characteristics of the DC-AC inverter for the lamp. When you design or order the inverter, please make sure that a poor lighting caused by the mismatch of the back light and the inverter (miss-lighting, flicker, etc.) never occurs. When you confirm it, the module should be operated in the same condition as it is installed in your instrument.

7-2 Input Data Signals and Display Position on the screen

Graphics and texts can be displayed on a $1280 \times 3 \times 1024$ dots panel with 16M colors by supplying 48 bit data signal (8bit/color [256 gray scale] $\times 3 \times 2$ pixels).

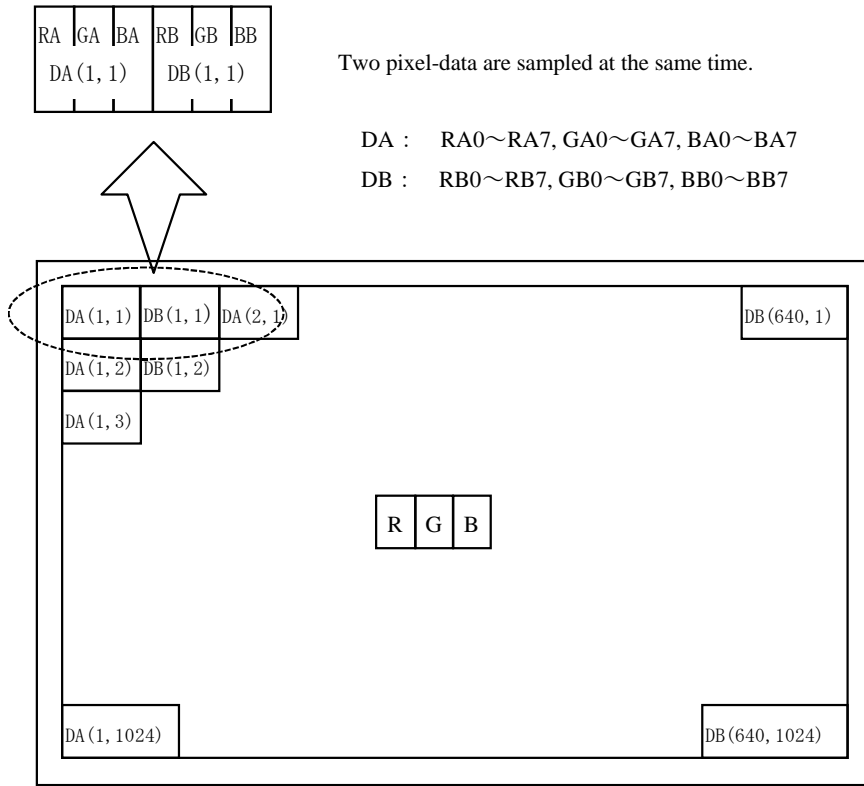

Display position of input data(H,V)

8. Input Signals, Basic Display Colors and Gray Scale of Each Color

Colors & Gray scale	Data signal																											
	Gray Scale	RA0	RA1	RA2	RA3	RA4	RA5	RA6	RA7	GA0	GA1	GA2	GA3	GA4	GA5	GA6	GA7	BA0	BA1	BA2	BA3	BA4	BA5	BA6	BA7			
		RB0	RB1	RB2	RB3	RB4	RB5	RB6	RB7	GB0	GB1	GB2	GB3	GB4	GB5	GB6	GB7	BB0	BB1	BB2	BB3	BB4	BB5	BB6	BB7			
Basic Color	Black	—	0	0	0	0	0	0	0	0	0	0	0	0	0	0	0	0	0	0	0	0	0	0	0	0		
	Blue	—	0	0	0	0	0	0	0	0	0	0	0	0	0	0	0	1	1	1	1	1	1	1	1	1		
	Green	—	0	0	0	0	0	0	0	0	1	1	1	1	1	1	1	0	0	0	0	0	0	0	0	0		
	Cyan	—	0	0	0	0	0	0	0	0	1	1	1	1	1	1	1	1	1	1	1	1	1	1	1	1		
	Red	—	1	1	1	1	1	1	1	1	0	0	0	0	0	0	0	0	0	0	0	0	0	0	0	0		
	Magenta	—	1	1	1	1	1	1	1	1	0	0	0	0	0	0	0	1	1	1	1	1	1	1	1	1		
	Yellow	—	1	1	1	1	1	1	1	1	1	1	1	1	1	1	1	0	0	0	0	0	0	0	0	0		
	White	—	1	1	1	1	1	1	1	1	1	1	1	1	1	1	1	1	1	1	1	1	1	1	1	1		
Gray Scale of Red	Black	GS0	0	0	0	0	0	0	0	0	0	0	0	0	0	0	0	0	0	0	0	0	0	0	0			
	↑	GS1	1	0	0	0	0	0	0	0	0	0	0	0	0	0	0	0	0	0	0	0	0	0	0			
	Darker	GS2	0	1	0	0	0	0	0	0	0	0	0	0	0	0	0	0	0	0	0	0	0	0	0			
	↑	↓				↓							↓								↓							
	↓	↓				↓							↓								↓							
	Brighter	GS250	1	0	1	1	1	1	1	1	0	0	0	0	0	0	0	0	0	0	0	0	0	0	0			
	↓	GS251	0	1	1	1	1	1	1	1	0	0	0	0	0	0	0	0	0	0	0	0	0	0	0			
	Red	GS252	1	1	1	1	1	1	1	1	0	0	0	0	0	0	0	0	0	0	0	0	0	0	0			
Gray Scale of Green	Black	GS0	0	0	0	0	0	0	0	0	0	0	0	0	0	0	0	0	0	0	0	0	0	0	0			
	↑	GS1	0	0	0	0	0	0	0	0	1	0	0	0	0	0	0	0	0	0	0	0	0	0	0			
	Darker	GS2	0	0	0	0	0	0	0	0	0	1	0	0	0	0	0	0	0	0	0	0	0	0	0			
	↑	↓				↓							↓								↓							
	↓	↓				↓							↓								↓							
	Brighter	GS250	0	0	0	0	0	0	0	0	1	0	1	1	1	1	1	0	0	0	0	0	0	0	0			
	↓	GS251	0	0	0	0	0	0	0	0	0	1	1	1	1	1	1	0	0	0	0	0	0	0	0			
	Green	GS252	0	0	0	0	0	0	0	0	1	1	1	1	1	1	1	0	0	0	0	0	0	0	0			
Gray Scale of Blue	Black	GS0	0	0	0	0	0	0	0	0	0	0	0	0	0	0	0	0	0	0	0	0	0	0	0			
	↑	GS1	0	0	0	0	0	0	0	0	0	0	0	0	0	0	0	1	0	0	0	0	0	0	0			
	Darker	GS2	0	0	0	0	0	0	0	0	0	0	0	0	0	0	0	0	1	0	0	0	0	0	0			
	↑	↓				↓							↓								↓							
	↓	↓				↓							↓								↓							
	Brighter	GS250	0	0	0	0	0	0	0	0	0	0	0	0	0	0	0	1	0	1	1	1	1	1	1			
	↓	GS251	0	0	0	0	0	0	0	0	0	0	0	0	0	0	0	0	1	1	1	1	1	1	1			
	Blue	GS252	0	0	0	0	0	0	0	0	0	0	0	0	0	0	0	1	1	1	1	1	1	1	1			

0 : Low level voltage, 1 : High level voltage.

Each basic color can be displayed in 256 gray scales from 8 bit data signals. According to the combination of total 48 bit data signals, the 16-million-color display can be achieved on the screen.

9. Optical Characteristics

Ta=25°C, Vcc=+12V

Parameter		Symbol	Condition	Min.	Typ.	Max.	Unit	Remark
Viewing Angle range	Vertical	θ11	CR=10	70	85	-	Deg.	【Note1,4】
		θ12		70	85	-	Deg.	
	Horizontal	θ21, θ22		70	85	-	Deg.	
Contrast ratio		CR	θ=0°	-	400	-		【Note2,4】
Response Time	Decay	τd		-	5	25	ms	【Note3,4】
	Rise	τr		-	20	50	ms	
Chromaticity of white		Wx		0.278	0.308	0.338	-	【Note4】
		Wy		0.290	0.320	0.350	-	
Chromaticity of red		Rx		0.612	0.642	0.672	-	
		Ry		0.309	0.339	0.369	-	
Chromaticity of green		Gx		0.260	0.290	0.320	-	
		Gy		0.578	0.608	0.638	-	
Chromaticity of blue		Bx		0.113	0.143	0.173	-	
		By		0.055	0.085	0.115	-	
Luminance of white		YL		180	220	-	cd/m ²	IL=6.0mA rms FL=60KHz 【Note4】
White Uniformity		δ w		-	-	1.25	-	【Note5】

* The measurement shall be executed 30 minutes after lighting at rating.

The optical characteristics shall be measured in the state of module only in a dark room or equivalent state with the method shown in Fig.4 below.

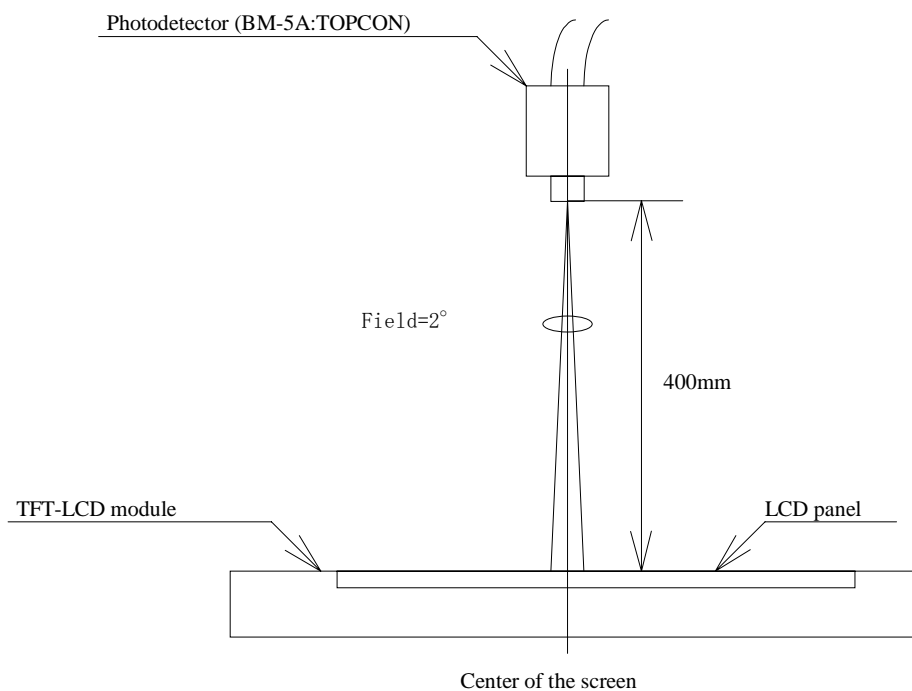
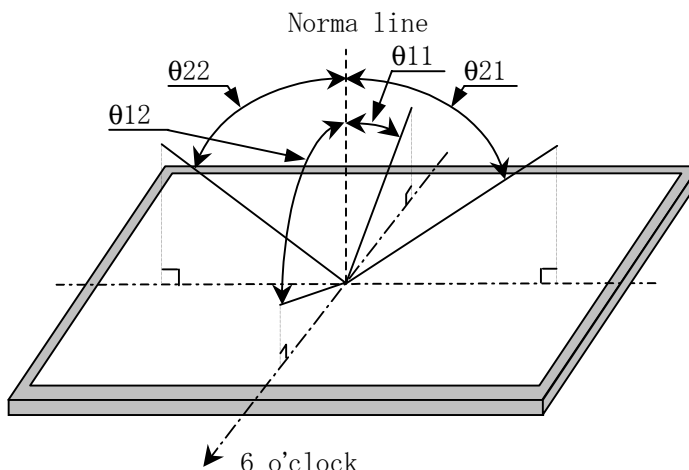

Fig.4 Optical characteristics measurement method

【Note1】 Definitions of viewing angle range:



【Note2】 Definition of contrast ratio:

The contrast ratio is defined as the following.

$$\text{Contrast Ratio (CR)} = \frac{\text{Luminance (brightness) with all pixels white}}{\text{Luminance (brightness) with all pixels black}}$$

【Note3】 Definition of response time:

The response time is defined as the following figure and shall be measured by switching the input signal for "black" and "white".

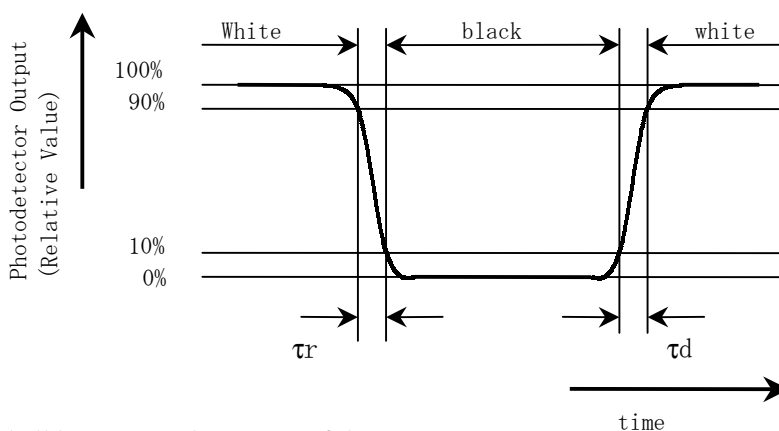

【Note4】 This shall be measured at center of the screen.

【Note5】 Definition of white uniformity:

White uniformity is defined as the following with five measurements (A~E).

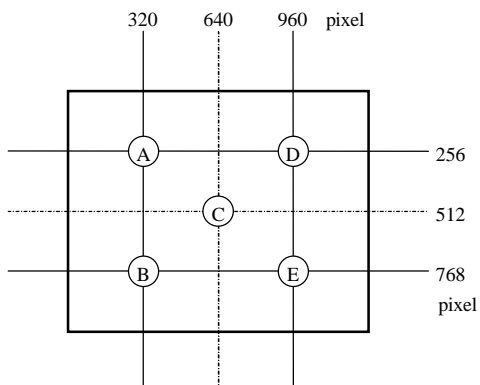

$$\delta_w = \frac{\text{Maximum Luminance of five points (brightness)}}{\text{Minimum Luminance of five points (brightness)}}$$

10. Handling Precautions

- a) Be sure to turn off the power supply when inserting or disconnecting the cable.
- b) Be sure to design the cabinet so that the module can be installed without any extra stress such as warp or twist.
- c) Since the front polarize is easily damaged, pay attention not to scratch it.
- d) Since long contact with water may cause discoloration or spots, wipe off water drop immediately.
- e) When the panel surface is soiled, wipe it with absorbent cotton or other soft cloth.
- f) Since the panel is made of glass, it may break or crack if dropped or bumped on hard surface. Handle with care.
- g) Since CMOS LSI is used in this module, take care of static electricity and take the human earth into consideration when handling.
- h) Make sure the four mounting holes of the module are grounded sufficiently. Take electro-magnetic interference (EMI) into consideration.
- i) The module has some printed circuit boards (PCBs) on the back side. Take care to keep them from any stress or pressure when handling or installing the module; otherwise some of electronic parts on the PCBs may be damaged.
- j) Observe all other precautionary requirements in handling components.
- k) When some pressure is added onto the module from rear side constantly, it causes display non-uniformity issue , functional defect, etc. So, please avoid such design.
- l) When giving a touch to the panel at power supply, it may cause some kinds of degradation. In that case, once turn off the power supply, and turn on after several seconds again, and that is disappear.
- m) When handling LCD modules and assembling them into cabinets, please be noted that long-term storage in the environment of oxidization or deoxidization gas and the use of such materials as reagent, solvent, adhesive, resin, etc. which generate these gasses, may cause corrosion and discoloration of the LCD modules.

11. Packing form

- a) Piling number of cartons : maximum 10 cartons
- b) Packing quantity in one carton : 2 module
- c) Carton size : 543mm(W) × 463mm(H) × 172(D)
- d) Total mass of one carton filled with full modules : 9.5kg
- e) Packing form is shown in Fig.5

12. Reliability test items

No.	Test item	Conditions
1	High temperature storage test	Ta=60°C 240h
2	Low temperature storage test	Ta=-25°C 240h
3	High temperature & high humidity operation test	Ta=40°C ; 95%RH 240h (No condensation)
4	High temperature operation test	Ta=50°C 240h (The panel temp. must be less than 60°C)
5	Low temperature operation test	Ta=0°C 240H
6	Vibration test (non- operating)	Waveform : Sine wave Frequency : 10 ~ 57Hz/Vibration width (one side) : 0.075mm : 58 ~ 500Hz/Gravity : 9.8m/s ² Sweep time : 11minutes Test period : 3 hours (1 hour for each direction of X,Y,Z)
7	Shock test (non- operating)	Max. gravity : 490m/s ² Pulse width : 11ms, sine wave Direction : ± X, ± Y, ± Z, once for each direction.
8	Thermal shock test	Ta=-20°C~60°C ; 5 cycles Test period : 10 hours (1 hour for each temperature)
9	Altitude	Ta=50°C,70kPa,3,048m(10,000ft), t=24h (Operating) Ta=50°C,18.75kpa,12,192m(40,000ft), t=24h (Storage)

【Result Evaluation Criteria】

Under the display quality test conditions with normal operation state, these shall be no change which may affect practical display function.

13. Others

1) Lot No. and indication Label:

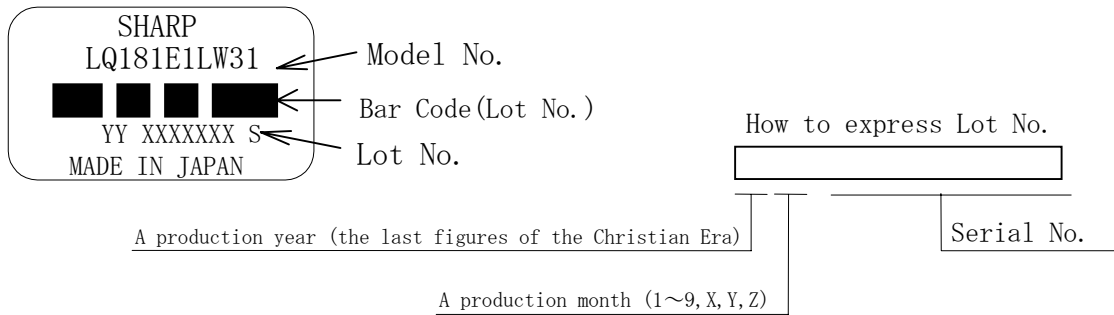

- 2) Adjusting volume have been set optimally before shipment, so do not change any adjusted value.
If adjusted value is changed, the specification may not be satisfied.
- 3) Disassembling the module can cause permanent damage and should be strictly avoided.
- 4) Please be careful since image retention may occur when a fixed pattern is displayed for a long time.
- 5) The chemical compound which causes the destruction of ozone layer is not being used.
- 6) Material information of LPG(Light Pipe Guide) are labeled on the back of the module.

MATERIAL INFORMATION
>PLASTIC LIGHT GUIDE·PMMA<

- 7) Cold cathode fluorescent lamp in LCD PANEL contains a small amount of mercury, Please follow local ordinances or regulations for disposal. (put on the back of the module. :Size: 63×14mm)

COLD CATHODE FLUORESCENT LAMP IN LCD PANEL
CONTAINS A SMALL AMOUNT OF MERCURY, PLEASE FOLLOW
LOCAL ORDINANCES OR REGULATION FOR DISPOSAL
当該液晶ディスプレイパネルは蛍光管が組み込まれていますので、地方自治体の条例、または、規則に従って廃棄ください。

- 8) When any question or issue occurs , it shall be solved by mutual discussion.

14. Carton storage condition

Temperature	0°C to 40°C
Humidity	95%RH or less
Reference condition :	20°C to 35°C , 85%RH or less (summer)
	: 5°C to 15°C , 85%RH or less (winter)
	• the total storage time (40°C,95%RH) : 240H or less
Sunlight	Be sure to shelter a product from the direct sunlight.
Atmosphere	Harmful gas, such as acid and alkali which bites electronic components and/or wires, must not be detected.
Notes	Be sure to put cartons on palette or base, don't put it on floor, and store them with removing from wall Please take care of ventilation in storehouse and around cartons, and control changing temperature is within limits of natural environment
Storage period	1 year

NOTES
 1) UNSPECIFIED TOLERANCE TO BE ± 0.5
 2) WARP AND FLATING FOR PCB AND CHASSIS ARE EXCLUDED FROM THICKNESS AND DIMENSIONS OF THE UNIT

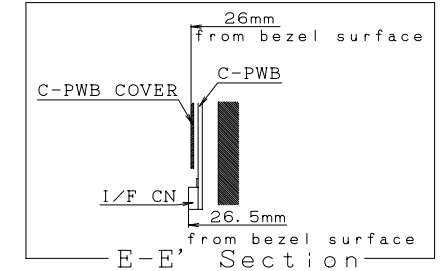
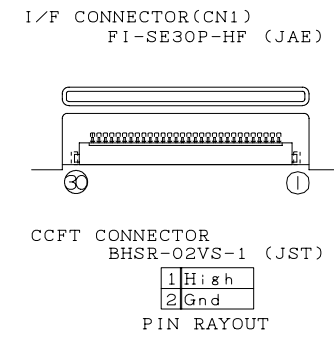
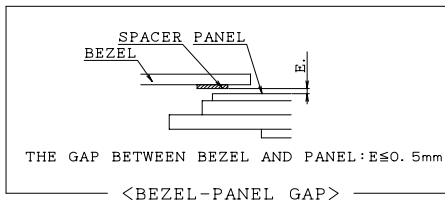
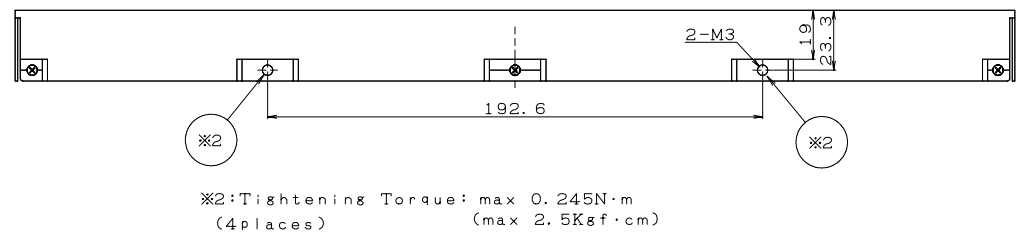
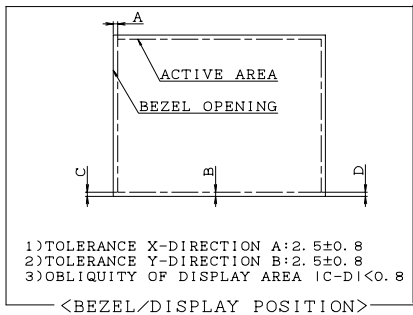
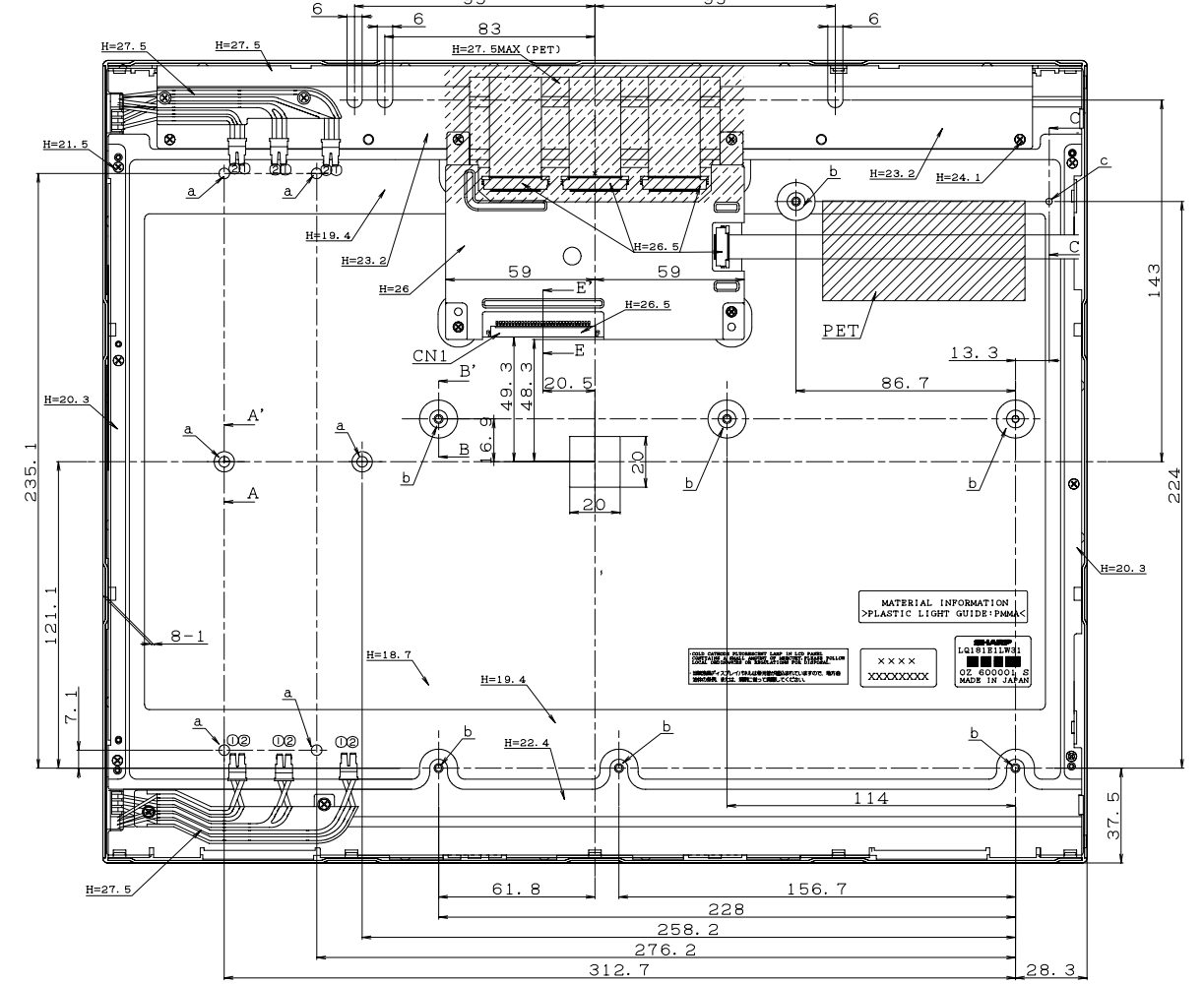
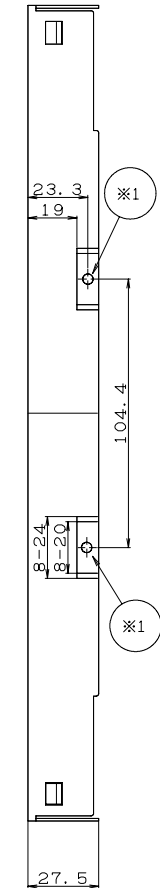
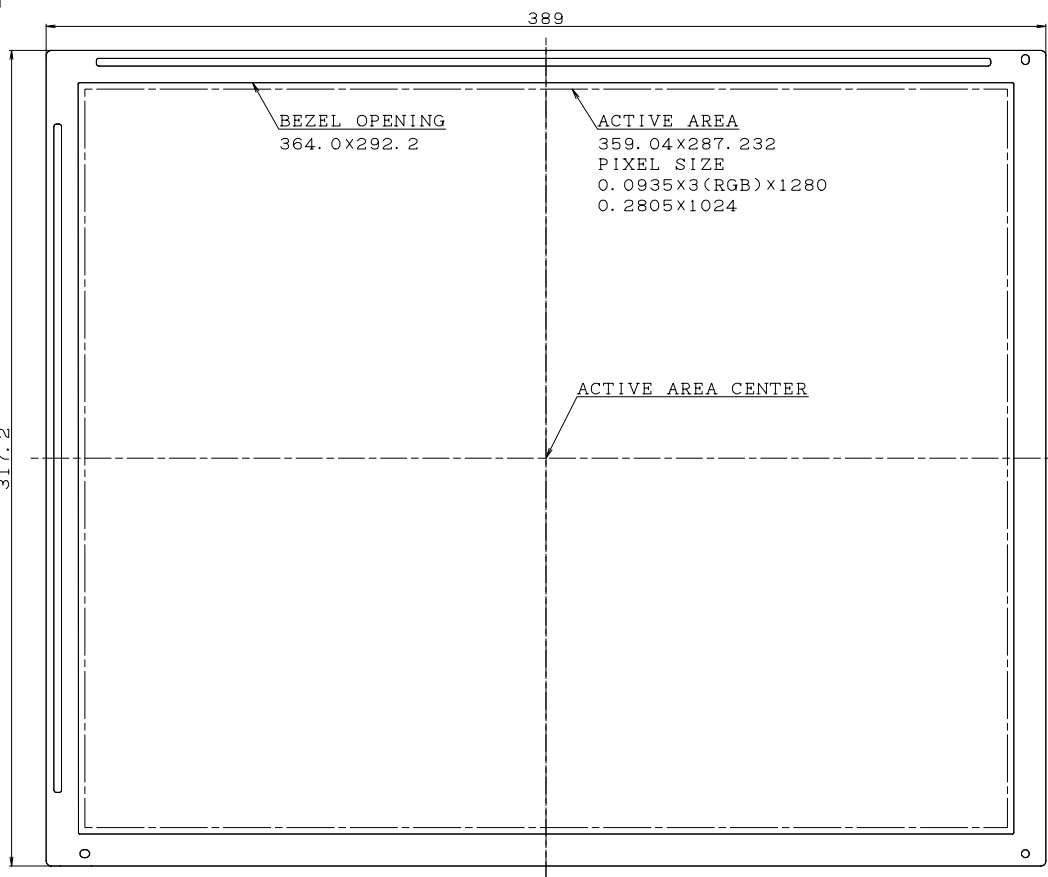
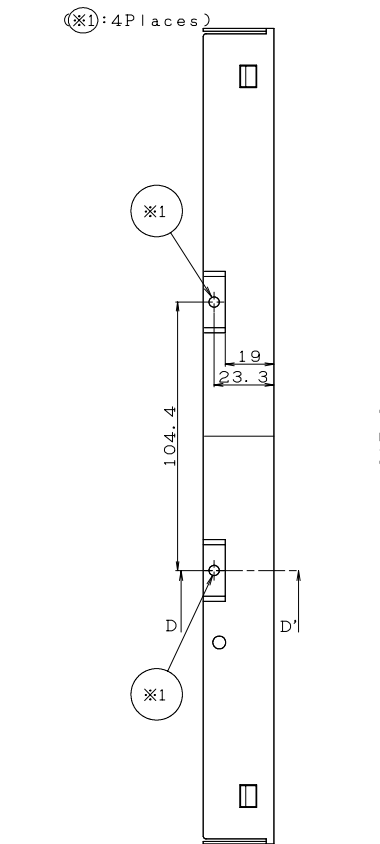
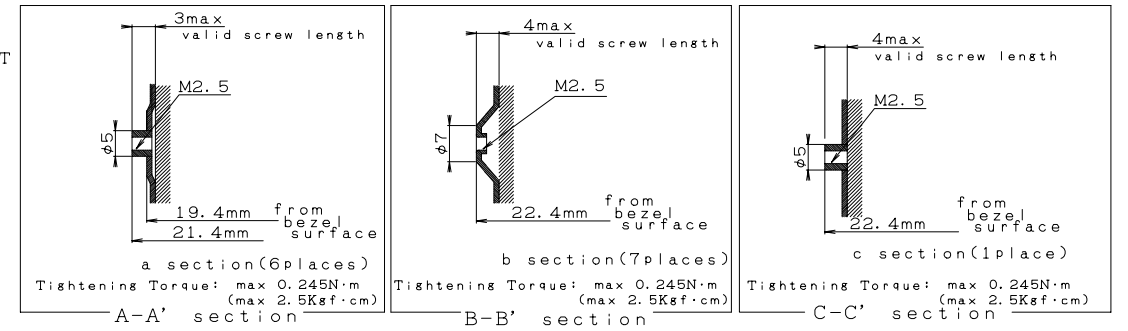
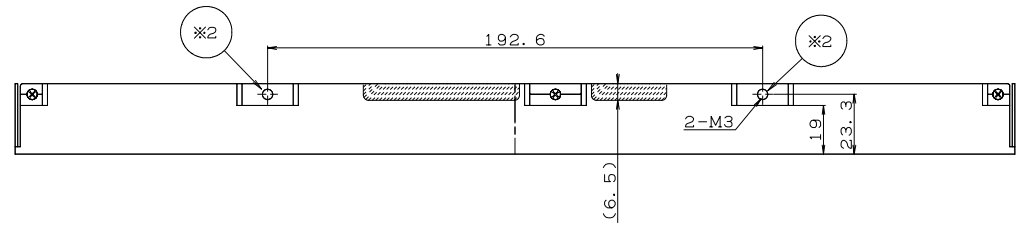
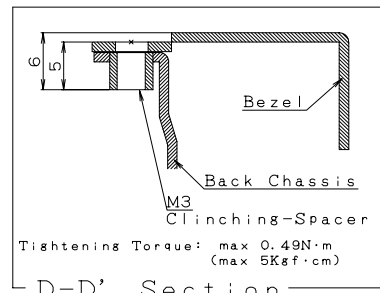
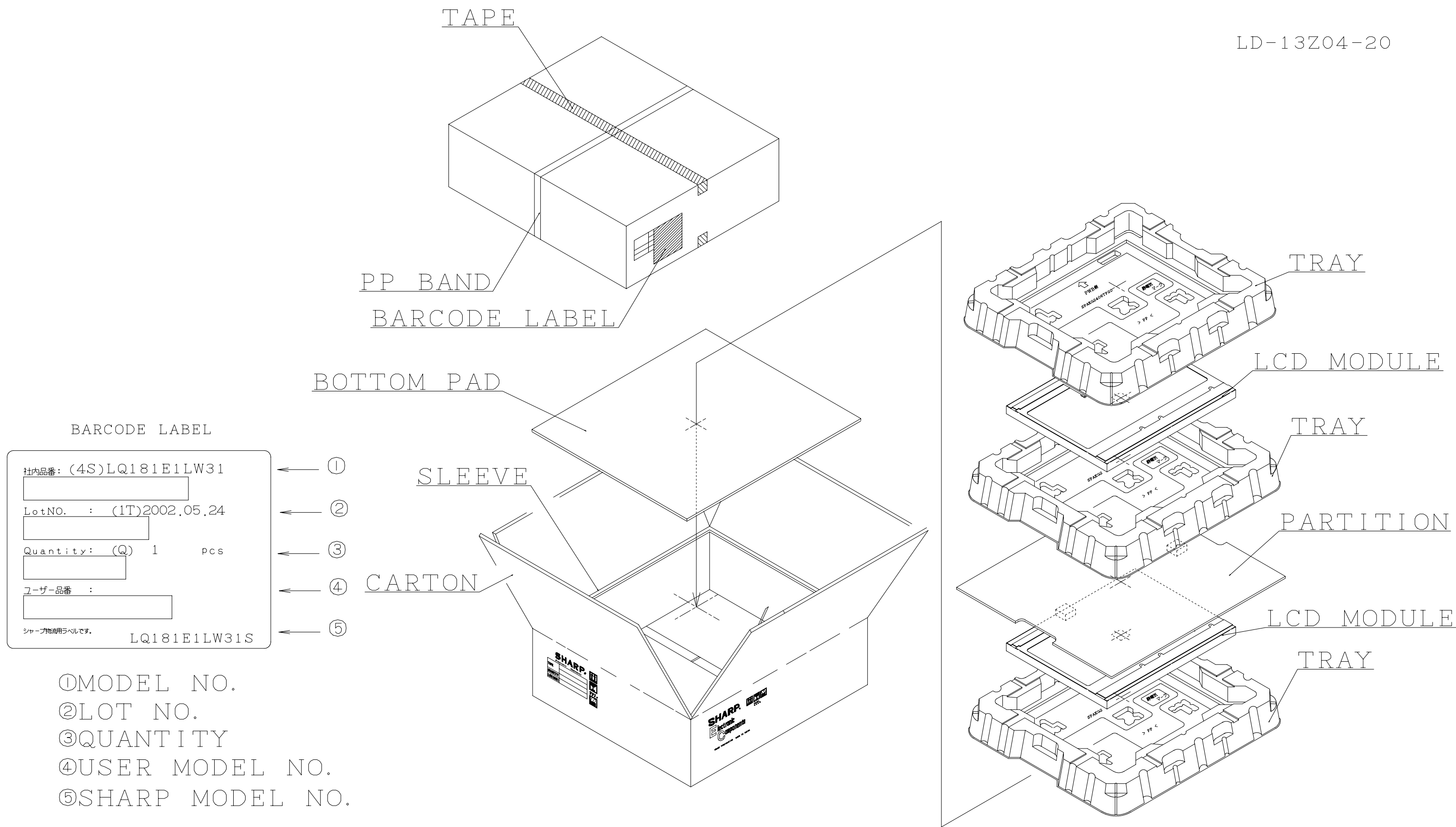

Fig 1. LQ181E1LW31 OUTLINE DIMENSIONS



- ①MODEL NO.
- ②LOT NO.
- ③QUANTITY
- ④USER MODEL NO.
- ⑤SHARP MODEL NO.

Fig5. Packing Form

SPECIFICATIONS ARE SUBJECT TO CHANGE WITHOUT NOTICE.

Suggested applications (if any) are for standard use; See Important Restrictions for limitations on special applications. See Limited Warranty for SHARP's product warranty. The Limited Warranty is in lieu, and exclusive of, all other warranties, express or implied. ALL EXPRESS AND IMPLIED WARRANTIES, INCLUDING THE WARRANTIES OF MERCHANTABILITY, FITNESS FOR USE AND FITNESS FOR A PARTICULAR PURPOSE, ARE SPECIFICALLY EXCLUDED. In no event will SHARP be liable, or in any way responsible, for any incidental or consequential economic or property damage.

SHARP®

NORTH AMERICA

SHARP Microelectronics of the Americas
5700 NW Pacific Rim Blvd.
Camas, WA 98607, U.S.A.
Phone: (1) 360-834-2500
Fax: (1) 360-834-8903
Fast Info: (1) 800-833-9437
www.sharpsma.com

EUROPE

SHARP Microelectronics Europe
Division of Sharp Electronics (Europe) GmbH
Sonninstrasse 3
20097 Hamburg, Germany
Phone: (49) 40-2376-2286
Fax: (49) 40-2376-2232
www.sharpsme.com

JAPAN

SHARP Corporation
Electronic Components & Devices
22-22 Nagaike-cho, Abeno-Ku
Osaka 545-8522, Japan
Phone: (81) 6-6621-1221
Fax: (81) 6117-725300/6117-725301
www.sharp-world.com

TAIWAN

SHARP Electronic Components
(Taiwan) Corporation
8F-A, No. 16, Sec. 4, Nanking E. Rd.
Taipei, Taiwan, Republic of China
Phone: (886) 2-2577-7341
Fax: (886) 2-2577-7326/2-2577-7328

SINGAPORE

SHARP Electronics (Singapore) PTE., Ltd.
438A, Alexandra Road, #05-01/02
Alexandra Technopark,
Singapore 119967
Phone: (65) 271-3566
Fax: (65) 271-3855

KOREA

SHARP Electronic Components
(Korea) Corporation
RM 501 Geosung B/D, 541
Dohwa-dong, Mapo-ku
Seoul 121-701, Korea
Phone: (82) 2-711-5813 ~ 8
Fax: (82) 2-711-5819

CHINA

SHARP Microelectronics of China
(Shanghai) Co., Ltd.
28 Xin Jin Qiao Road King Tower 16F
Pudong Shanghai, 201206 P.R. China
Phone: (86) 21-5854-7710/21-5834-6056
Fax: (86) 21-5854-4340/21-5834-6057

Head Office:

No. 360, Bashen Road,
Xin Development Bldg. 22
Waigaoqiao Free Trade Zone Shanghai
200131 P.R. China
Email: smc@china.global.sharp.co.jp

HONG KONG

SHARP-ROXY (Hong Kong) Ltd.
3rd Business Division,
17/F, Admiralty Centre, Tower 1
18 Harcourt Road, Hong Kong
Phone: (852) 28229311
Fax: (852) 28660779
www.sharp.com.hk

Shenzhen Representative Office:

Room 13B1, Tower C,
Electronics Science & Technology Building
Shen Nan Zhong Road
Shenzhen, P.R. China
Phone: (86) 755-3273731
Fax: (86) 755-3273735