

42-DL312

Version : A.06
Issue Date : 2004-04-19
File Name : 42-DL312-A.06.doc
Total Pages: 6

Optical Fiber Receiving IC

Preliminary



SITI

新竹市展業一路九號四樓之三

SILICON TOUCH TECHNOLOGY INC.

9-4F-3, Prosperity Road I, Hsin-Chu, Taiwan, R.O.C.

Tel : 886-3-5645656

Fax : 886-3-5645626

42-DL312

OPTICAL FIBER RECEIVING IC

GENERAL DESCRIPTION

42-DL312 receiver is designed for the application of high-speed optical fiber transmission. As an OEIC, 42-DL312 integrates photo sensor, ATC (Automatic Threshold Control) and signal processing circuit for high-speed application, and is fabricated by using CMOS technology. 42-DL312 is designed to operate by positive logic in which the output voltage is set to high level when optical flux is received.

FEATURES

1. Low jitter (Δt_j : TYP. 1ns)
2. High speed (Up to 13.2Mb/s, NRZ signal)
3. Built-in photo sensor and signal processing circuit.
4. Built-in ATC (Automatic Threshold Control) circuit used for stabilized output at a wide range of optical power level

BLOCK DIAGRAM And APPLICATION CIRCUIT

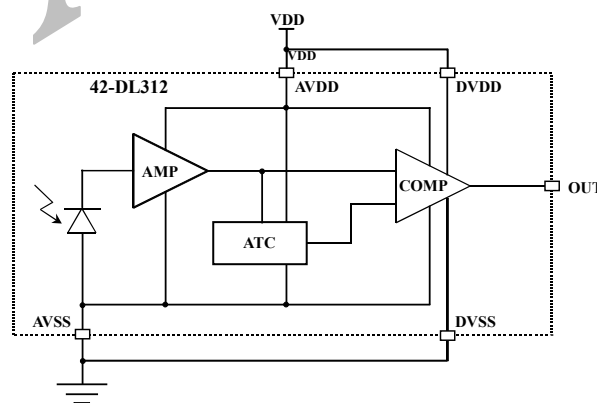

ABSOLUTE MAXIMUM RATINGS (Ta=25°C)

Item	Symbol	Rating	Unit
Supply Voltage	V _{DD}	-0.5 to +7	V
Power dissipation	P	100	mW
Operating Temperature	Topr	-40 to +85	°C
Storage Temperature	Tstg	-55 to +100	°C
High Level Output Current	I _{OH}	-1	mA
Low Level Output Current	I _{OL}	20	mA

RECOMMENDED OPERATING CONDITIONS

ITEM	SYMBOL	MIN.	TYP.	MAX.	UNIT
Supply Voltage	V _{DD}	4.75	5.0	5.25	V
High Level Output Current	I _{OH}	-	-	-150	uA
Low Level Output Current	I _{OL}	-	-	1.6	mA

ELECTRICAL CHARACTERISTICS (V_{DD}=5.0V, T_A=25°C)

ITEM	SYMBOL	CONDITIONS	MIN.	TYP.	MAX.	UNIT
Peak sensitivity wavelength	λ _P	-	-	700	-	nm
Maximum Input Optical Power for High level	P _{CMAX}	Input optical wavelength=650nm	-17.5	-	-	dBm
Minimum Input Optical Power for High level	P _{CMIN}	Input optical wavelength=650nm	-	-	-24	dBm
Current Consumption	I _{DD}	-	-	5	10	mA
High Level Output Voltage	V _{OH}	V _{DD} = 5V I _{OH} = -0.15mA	2.4	-	V _{DD}	V
Low Level Output Voltage	V _{OL}	V _{DD} = 5V I _{OL} = -1.6mA	0	-	0.4	V
Rise Time	Tr	C _L =10pF	-	4.5	6	ns
Fall Time	Tf	C _L =10pF	-	4.5	6	ns
Pulse Width Distortion (note.1)	Δtw	Pulse width=165ns Pulse cycle=330ns, C _L =10pF	-17	-	17	ns
Jitter	Δtj	PC=-15dBm	-	1	10	ns
		PC=-24dBm	-	-	10	ns
Data Rate	F _{DATA}	NRZ Code, Duty 50% Input	0.1	-	13.2	Mb/s

Note.1 Between input of an optical fiber transmitting module and output of 42-DL312.

PAD DESCRIPTIONS

Pad Name	Size	Center Coordinates (unit: um)	I/O	Description
VDD_A	100um*100um	(60, 728.15)	Power	Analog Power Supply
VDD_D	100um*100um	(60, 60)	Power	Digital Power Supply
VSS_A	100um*100um	(634.7, 72.4)	Ground	Analog Power Ground
VSS_D	100um*100um	(509.7, 72.4)	Ground	Digital Power Ground
OUT	100um*100um	(910.5, 72.4)	Output	Signal Output

DIE CONFIGURATION

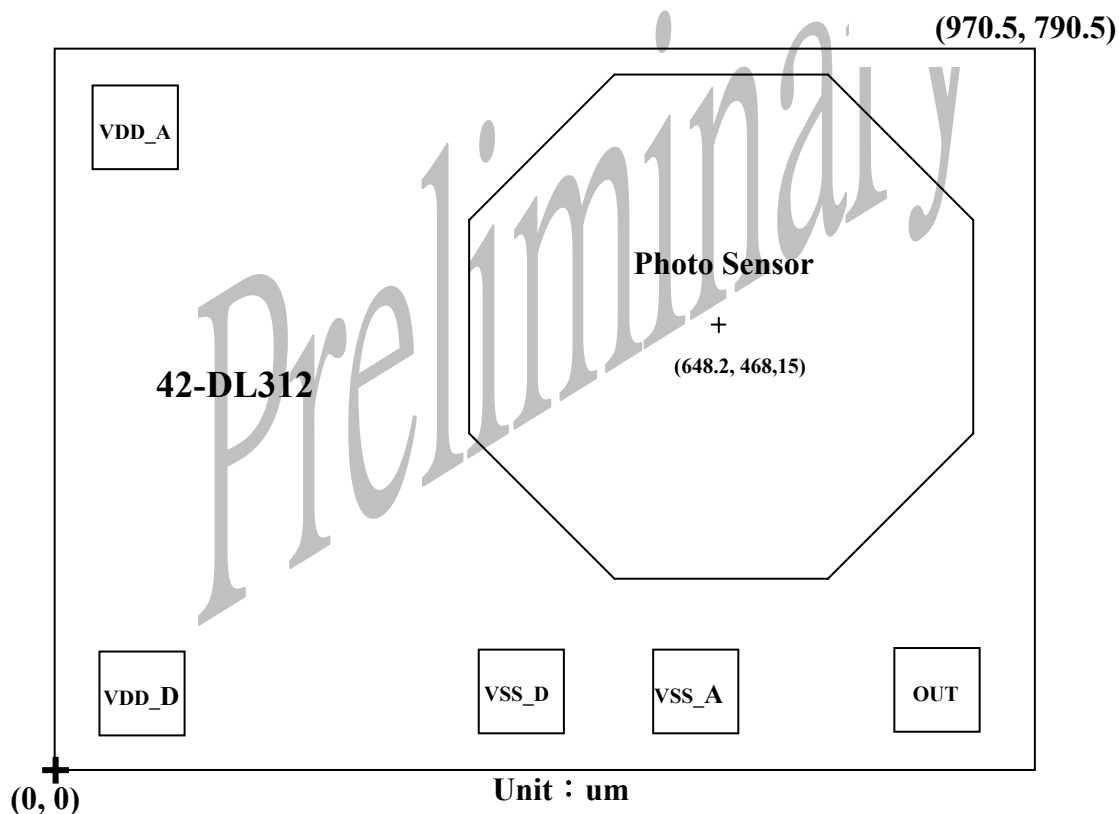

Die Size: 970.5um*790.5um

PD Size: 250000um×1

The Center Coordinates of PD: (648.2um, 468.15um)

* **Note:** SiTI reserves the right to alter the device geometry and manufacturing processes without prior notice. Though these alterations may result in geometrical changes, they will not affect die electrical characteristics and pad layouts in any sense.

REQUIREMENTS FOR WAFER DELIVERY

Material : Silicon with P-Substrate
Diameter : 6 inches(\approx 15cm)
Thickness : 12 mils(\approx 300um)
Scribe Line Width : 110um
Malfunctioned die : Marked with red ink or equivalent marking

HANDLING RECOMMENDATION FOR STATIC ELECTRICITY PROTECTION

- (1) Avoid any circumstance that produce static electricity, e.g. rubbing against plastic, during moving, storing and processing 42-DL312.
- (2) Process 42-DL312 in a clean room with proper temperature and humidity.
- (3) Ground all working machines and workers wear anti-electrostatic ring to ground during processing.
- (4) Avoid contact 42-DL312 with bare hands .If unavoided, wear anti-electrostatic ring and use anti-electrostatic tool to pick it up.

GUARANTEED TEMPERATURE AND RETENTION CYCLE

- (1) The device/wafer 42-DL312 should be stored in the nitrogenous chest. The conditions suggested are as follows:
 - Temperature = $23\pm 3^{\circ}\text{C}$
 - Relative Humidity = $50\pm 10\%$
 - Minimum nitrogen inflow = 3 liters/minute
- (2) If the device/wafer, 42-DL312 is incidentally exposed to the air, use it for manufacturing as soon as possible.
- (3) Under the storage environment specified in item (1), six-month safe storage period is guaranteed.



The products listed herein are designed for ordinary electronic applications, such as electrical appliances, audio-visual equipment, communications devices and so on. Hence, it is advisable that the devices should not be used in medical instruments, surgical implants, aerospace machinery, nuclear power control systems, disaster/crime-prevention equipment and the like. Misusing those products may directly or indirectly endanger human life, or cause injury and property loss.

Silicon Touch Technology, Inc. will not take any responsibilities regarding the misuse of the products mentioned above. Anyone who purchases any products described herein with the above-mentioned intention or with such misused applications should accept full responsibility and indemnify. Silicon Touch Technology, Inc. and its distributors and all their officers and employees shall defend jointly and severally against any and all claims and litigation and all damages, cost and expenses associated with such intention and manipulation.

Preliminary