

ECL25 Series

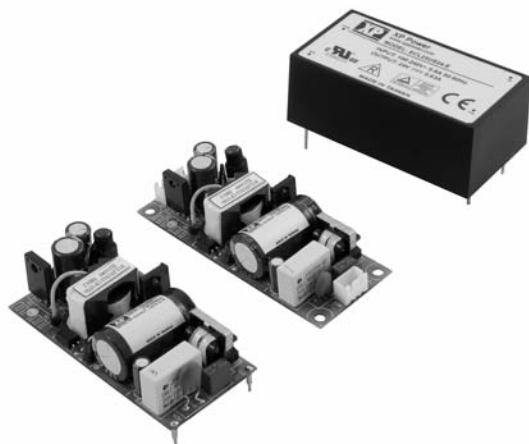

- Ultra Compact Size
- Low Cost
- Single Outputs from 3.3 to 48 V
- PCB Mount & Open Frame
- Encapsulated PCB Mount
- Class II
- Peak Load Capability

Specification

Input

Input Voltage	• 85-264 VAC (120-370 VDC)
Input Frequency	• 47-63 Hz
Input Current	• 0.4 A rms at 230 VAC
Inrush Current	• 20 A at 115 VAC, 40 A at 230 VAC,
Earth Leakage Current	• Class II construction no earth
Input Protection	• Internal 2 A fuse

Output

Output Voltage	• See tables
Output Voltage Trim	• $\pm 5\%$ (not encapsulated units)
Initial Set Accuracy	• $\pm 1\%$
Minimum Load	• No minimum load required
Start Up Delay	• 2 s max
Start Up Rise Time	• 14 ms max
Hold Up Time	• 16 ms typical at full load & 115 VAC
Line Regulation	• $\pm 0.5\%$ max
Load Regulation	• $\pm 1\%$ max
Transient Response	• 4% max deviation, recovery to within 1% in 500 μ s for a 25% load change
Ripple & Noise	• 3.3-5 V versions: 50 mV pk-pk, 12-15 V versions: 120 mV pk-pk, 24-48 V versions: 200 mV pk-pk, 20 MHz BW
Overvoltage Protection	• 115-135% Vnom, recycle input to reset
Overload Protection	• 120-170%
Short Circuit Protection	• Trip and restart (Hiccup mode)
Temperature Coefficient	• 0.05%/ $^{\circ}$ C

General

Efficiency	• See tables
Isolation	• 3000 VAC Input to Output
Switching Frequency	• 70 kHz typical
Power Density	• 5.6 W/In ³ (PCB Mount version)
MTBF	• >400 kHrs per MIL-HDBK-217F

Environmental

Operating Temperature	• -20 $^{\circ}$ C to +70 $^{\circ}$ C, derate linearly from 100% at +50 $^{\circ}$ C to 50% at +70 $^{\circ}$ C
Cooling	• Convection-cooled
Operating Humidity	• 95% RH, non-condensing
Storage Temperature	• -40 $^{\circ}$ C to +85 $^{\circ}$ C
Operating Altitude	• 3000 m
Vibration	• 2 g, 10 Hz to 500 kHz, 10 mins/cycle, 60 mins each cycle

EMC & Safety

Emissions	• EN55022, level B conducted & radiated
Harmonic Currents	• EN61000-3-2, EN61000-3-3
ESD Immunity	• EN61000-4-2, level 3 Perf Criteria A
Radiated Immunity	• EN61000-4-3, 10 V/m 80% mod Perf Criteria A
EFT/Burst	• EN61000-4-4, level 3 Perf Criteria A
Surge	• EN61000-4-5, level 3 Perf Criteria A
Conducted Immunity	• EN61000-4-6, 10 Vrms Perf Criteria A
Magnetic Fields	• EN61000-4-8, 10 A/m Perf Criteria A
Dips & Interruptions	• EN61000-4-11, 70% U _r for 10 ms, 40% U _r for 100 ms, <5% U _r for 5000 ms Perf Criteria A, B, B
Safety Approvals	• EN60950, UL60950, CSA22.2 No. 234 per cUL

Models and Ratings

Output Power	Output Voltage	Output Current		Efficiency	Model Number ⁽²⁾
		Nominal	Peak ⁽¹⁾		
20 W	3.3 VDC	6.00 A	7.80 A	75%	ECL25US03
25 W	5.0 VDC	5.00 A	6.50 A	78%	ECL25US05
25 W	9.0 VDC	2.80 A	3.64 A	80%	ECL25US09
25 W	12.0 VDC	2.10 A	2.73 A	80%	ECL25US12
25 W	15.0 VDC	1.67 A	2.17 A	80%	ECL25US15
25 W	24.0 VDC	1.04 A	1.35 A	82%	ECL25US24
25 W	48.0 VDC	0.52 A	0.68 A	82%	ECL25US48

Notes

1. Peak load lasting <30 s with a maximum duty cycle of 10%, average output power not to exceed nominal.
2. Add suffix to model number to define type: add '-P' for PCB mount, add '-T' for chassis mount, add '-E' for encapsulated.

Mechanical Details

Open Frame - PCB Mount (-P)

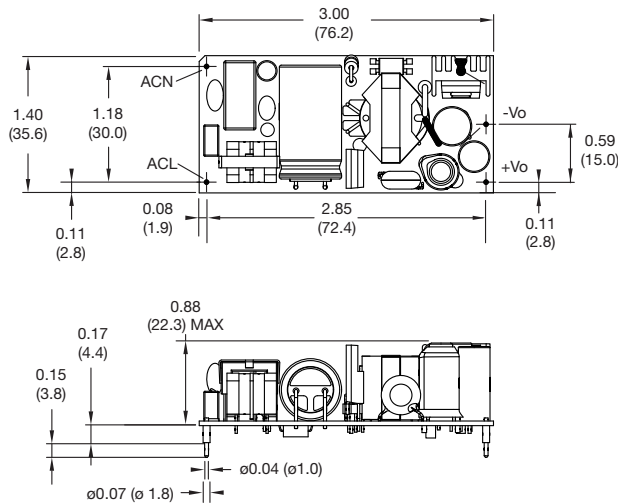

Encapsulated (-E)

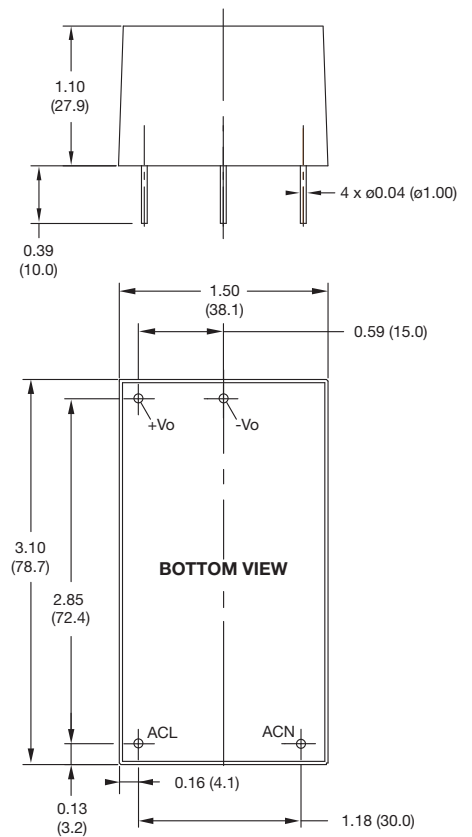

Open Frame - Chassis Mount (-T)

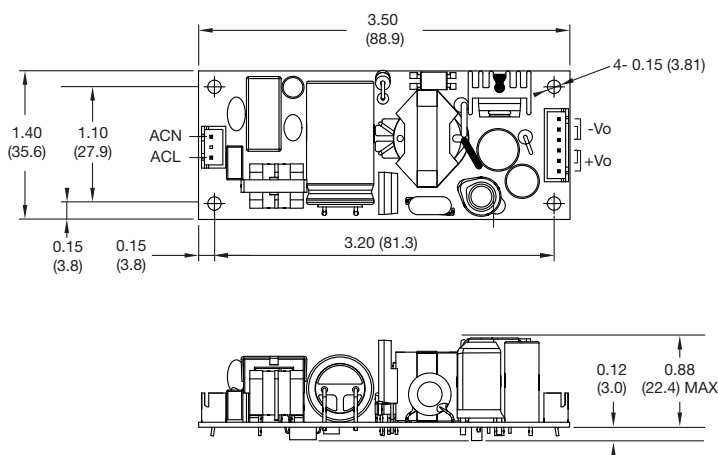

Notes

1. Dimensions in inches (mm).
2. Tolerances: x.xx = ± 0.02 (x.x = ± 0.5)
x.xxx = ± 0.01 (x.xx = ± 0.25)

Mating Connectors (Chassis mount only)

- Input Connector: JST XHP-3
- Output Connector: JST XHP-6
- Crimps: SXH-002T-P0.6
- Cable harness with 300 mm wire available, order part no. ECL25 LOOM KIT