

155Mbps SFP Transceiver with Spring Latch

(For 15km~80km transmission)

Members of Flexon™ Family



- ◆ Compatible with FCC 47 CFR Part 15, Class B
- ◆ Compatible with FDA 21 CFR 1040.10 and 1040.11, Class I
- ◆ Compliant with RoHS

Description

Fiberxon 155Mbps spring-latch SFP transceiver is high performance, cost effective modules that supports data-rate of 155Mbps and transmission distance from 15km to 80km.

The transceiver consists of two sections: The transmitter section incorporates a FP or uncooled DFB laser. And the receiver section consists of a PIN photodiode integrated with a trans-impedance preamplifier (TIA). All modules satisfy class I laser safety requirements.

The optical output can be disabled by a TTL logic high-level input of Tx Disable. Tx Fault is provided to indicate degradation of the laser. Loss of signal (LOS) output is provided to indicate the loss of an input optical signal of receiver.

The standard serial ID information Compatible with SFP MSA describes the transceiver's capabilities, standard interfaces, manufacturer and other information. The host equipment can access this information via the two-wire serial CMOS EEPROM protocol. For further information, please refer to SFP Multi-Source Agreement (MSA).

Features

- ◆ Up to 155Mbps data-rate
- ◆ 1310nm FP laser and PIN photodetector for 15km and 40km transmission
- ◆ 1550nm uncooled DFB laser and PIN photodetector for 80km transmission
- ◆ Standard serial ID information Compatible with SFP MSA
- ◆ SFP MSA package with duplex LC connector
- ◆ With spring latch for easily removing
- ◆ Very low EMI and excellent ESD protection
- ◆ +3.3V single power supply
- ◆ Operating case temperature:
Standard : 0 to +70°C
Industrial : -40 to +85°C

Applications

- ◆ SDH STM-1, S-1.1, L-1.1, L-1.2
- ◆ SONET OC-3 IR1, LR1, LR2
- ◆ Other optical links

Standard

- ◆ Compatible with SFP MSA
- ◆ Compatible with ITU-T G.957 and G.958
- ◆ Compatible with Telcordia GR-253-CORE

Regulatory Compliance

The transceivers have been tested according to American and European product safety and electromagnetic compatibility regulations (See Table 1). For further information regarding regulatory certification, please refer to Fiberxon regulatory specification and safety guidelines, or contact with Fiberxon, Inc. America sales office listed at the end of the documentation.

Table 1 - Regulatory Compliance

Feature	Standard	Performance
Electrostatic Discharge (ESD) to the Electrical Pins	MIL-STD-883E Method 3015.7	Class 1(>500 V)
Electrostatic Discharge (ESD) to the Duplex LC Receptacle	IEC 61000-4-2 GR-1089-CORE	Compatible with standards
Electromagnetic Interference (EMI)	FCC Part 15 Class B EN55022 Class B (CISPR 22B) VCCI Class B	Compatible with standards
Immunity	IEC 61000-4-3	Compatible with standards
Laser Eye Safety	FDA 21CFR 1040.10 and 1040.11 EN60950, EN (IEC) 60825-1,2	Compatible with Class 1 laser product. TUV Certificate No. 50030043
Component Recognition	UL and CSA	UL file E223705

Absolute Maximum Ratings

Stress in excess of the maximum absolute ratings can cause permanent damage to the module.

Table 2 - Absolute Maximum Ratings

Parameter	Symbol	Min.	Max.	Unit
Storage Temperature	T_s	-40	+85	°C
Supply Voltage	V_{CC}	-0.5	3.6	V
Operating Relative Humidity	-	5	95	%

Recommended Operating Conditions

Table 3- Recommended Operating Conditions

Parameter		Symbol	Min.	Typical	Max.	Unit
Operating Case Temperature	Standard	T_C	0		+70	°C
	Industrial		-40		+85	
Power Supply Voltage		V_{CC}	3.13	3.3	3.47	V
Power Supply Current		I_{CC}			300	mA
Data Rate				155		Mbps

FTM-3001C-SL15G, FTM-3001C-SL15iG (1310nm FP and PIN, 15km)
Table 4 - Optical and Electrical Characteristics

Parameter	Symbol	Min.	Typical	Max.	Unit	Notes
Transmitter						
Centre Wavelength	λ_C	1261		1360	nm	
Average Output Power	P_{Out}	-15		-8	dBm	1
Spectral Width (RMS)	σ			4	nm	
Extinction Ratio	EX	8.2			dB	
Jitter Generation (RMS)				0.01	UI	
Jitter Generation (pk-pk)				0.1	UI	
Output Optical Eye	Compatible with Telcordia GR-253-CORE and ITU-T G.957					2
Data Input Swing Differential	V_{IN}	300		1860	mV	3
Input Differential Impedance	Z_{IN}	90	100	110	Ω	
TX Disable	Disable	2.0		V_{CC}	V	
	Enable	0		0.8	V	
TX Fault	Fault	2.0		$V_{CC}+0.3$	V	
	Normal	0		0.8	V	
Receiver						
Centre Wavelength	λ_C	1260		1580	nm	
Receiver Sensitivity				-34	dBm	4
Receiver Overload		-8			dBm	4
Optical Path Penalty				1	dB	5
LOS De-Assert	LOS_D			-37	dBm	
LOS Assert	LOS_A	-45			dBm	
LOS Hysteresis		1		4	dB	
Data Output Swing Differential	V_{OUT}	370		1800	mV	6
LOS	High	2.0		$V_{CC}+0.3$	V	
	Low	0		0.8	V	

Notes:

1. The optical power is launched into SMF.
2. Measured with a PRBS $2^{23}-1$ test pattern @155Mbps.
3. PECL input, internally AC coupled and terminated.
4. Measured with a PRBS $2^{23}-1$ test pattern @155Mbps, BER $\leq 1 \times 10^{-10}$.
5. Measured with a PRBS $2^{23}-1$ test pattern @155Mbps, over 15km G.652 SMF, BER $\leq 1 \times 10^{-10}$.
6. Internally AC coupled.

FTM-3001C-SL40G, FTM-3001C-SL40iG (1310nm FP and PIN, 40km)
Table 5 - Optical and Electrical Characteristics

Parameter	Symbol	Min.	Typical	Max.	Unit	Notes
Transmitter						
Centre Wavelength	λ_C	1263		1360	nm	
Average Output Power	P_{Out}	-5		0	dBm	1
Spectral Width (RMS)	σ			3	nm	
Extinction Ratio	EX	10			dB	
Jitter Generation (RMS)				0.01	UI	
Jitter Generation (pk-pk)				0.1	UI	
Output Optical Eye	Compatible with Telcordia GR-253-CORE and ITU-T G.957					2
Data Input Swing Differential	V_{IN}	300		1860	mV	3
Input Differential Impedance	Z_{IN}	90	100	110	Ω	
TX Disable	Disable	2.0		V_{CC}	V	
	Enable	0		0.8	V	
TX Fault	Fault	2.0		$V_{CC}+0.3$	V	
	Normal	0		0.8	V	
Receiver						
Centre Wavelength	λ_C	1260		1580	nm	
Receiver Sensitivity				-34	dBm	4
Receiver Overload		-8			dBm	4
Optical Path Penalty				1	dB	5
LOS De-Assert	LOS_D			-37	dBm	
LOS Assert	LOS_A	-45			dBm	
LOS Hysteresis		1		4	dB	
Data Output Swing Differential	V_{OUT}	370		1800	mV	6
LOS	High	2.0		$V_{CC}+0.3$	V	
	Low	0		0.8	V	

Notes:

1. The optical power is launched into SMF.
2. Measured with a PRBS $2^{23}-1$ test pattern @155Mbps.
3. PECL input, internally AC coupled and terminated.
4. Measured with a PRBS $2^{23}-1$ test pattern @155Mbps, extinction ratio ER=10dB, BER $\leq 1 \times 10^{-10}$.
5. Measured with a PRBS $2^{23}-1$ test pattern @155Mbps, over 40km G.652 SMF, BER $\leq 1 \times 10^{-10}$.
6. Internally AC coupled.

FTM-5001C-SL80G (1550nm DFB and PIN, 80km)**Table 6 - Optical and Electrical Characteristics**

Parameter	Symbol	Min.	Typical	Max.	Unit	Notes
Transmitter						
Centre Wavelength	λ_C	1480		1580	nm	
Average Output Power	P_{Out}	-5		0	dBm	1
Spectral Width (-20dB)	$\Delta\lambda$			1	nm	
Side Mode Suppression Ratio	SMSR	30			dB	
Extinction Ratio	EX	10			dB	
Jitter Generation (RMS)				0.01	UI	
Jitter Generation (pk-pk)				0.1	UI	
Output Optical Eye	Compatible with Telcordia GR-253-CORE and ITU-T G.957					2
Data Input Swing Differential	V_{IN}	300		1860	mV	3
Input Differential Impedance	Z_{IN}	90	100	110	Ω	
TX Disable	Disable	2.0		V_{CC}	V	
	Enable	0		0.8	V	
TX Fault	Fault	2.0		$V_{CC}+0.3$	V	
	Normal	0		0.8	V	
Receiver						
Centre Wavelength	λ_C	1260		1580	nm	
Receiver Sensitivity				-34	dBm	4
Receiver Overload		-8			dBm	4
Optical Path Penalty				1	dB	5
LOS De-Assert	LOS_D			-37	dBm	
LOS Assert	LOS_A	-45			dBm	
LOS Hysteresis		1		4	dB	
Data Output Swing Differential	V_{OUT}	370		1800	mV	6
LOS	High	2.0		$V_{CC}+0.3$	V	
	Low	0		0.8	V	

Notes:

- The optical power is launched into SMF.
- Measured with a PRBS $2^{23}-1$ test pattern @155Mbps.
- PECL input, internally AC coupled and terminated.
- Measured with a PRBS $2^{23}-1$ test pattern @155Mbps, extinction ratio ER=10dB, BER $\leq 1 \times 10^{-10}$.
- Measured with a PRBS $2^{23}-1$ test pattern @155Mbps, over 80km G.652 SMF, BER $\leq 1 \times 10^{-10}$.
- Internally AC coupled.

EEPROM Information

The SFP MSA defines a 256-byte memory map in EEPROM describing the transceiver's capabilities, standard interfaces, manufacturer, and other information, which is accessible over a two-wire serial interface at the 8-bit address 1010000X (A0h). For memory contents please refer to Table 7.

Table 7 - EEPROM Serial ID Memory Contents (A0h)

Addr.	Field Size (Bytes)	Name of Field	Hex	Description
0	1	Identifier	03	SFP
1	1	Ext. Identifier	04	MOD4
2	1	Connector	07	LC
3—10	8	Transceiver	00 00 xx 00 00 00 00 00	OC 3, Single mode inter. or long reach
11	1	Encoding	03	NRZ
12	1	BR, nominal	01	155Mbps
13	1	Reserved	00	
14	1	Length (9um)-km	xx	15km/40km/80km(0F/28/50)
15	1	Length (9um)	xx	15km/40km/80km(96/FF/FF)
16	1	Length (50um)	00	
17	1	Length (62.5um)	00	
18	1	Length (copper)	00	
19	1	Reserved	00	
20—35	16	Vendor name	46 49 42 45 52 58 4F 4E 20 49 4E 43 2E 20 20 20	"FIBERXON INC." (ASC II)
36	1	Reserved	00	
37—39	3	Vendor OUI	00 00 00	
40—55	16	Vendor PN	46 54 4D 2D xx 30 30 31 43 2D 53 4C xx xx xx 47	"FTM-x001C-SLxx(i)G" (ASC II)
56—59	4	Vendor rev	xx xx 00 00	ASC II ("31 30 00 00" means 1.0 revision)
60—62	3	Reserved	00 00 00	
63	1	CC BASE	xx	Check sum of bytes 0 - 62
64—65	2	Options	00 1A	LOS, TX_FAULT and TX_DISABLE
66	1	BR, max	00	
67	1	BR, min	00	
68—83	16	Vendor SN	xx xx xx xx xx xx xx xx xx xx xx xx xx xx xx xx	ASC II.
84—91	8	Vendor date code	xx xx xx xx xx xx 20 20	Year (2 bytes, Month (2 bytes), Day (2 bytes))
92—94	3	Reserved	00 00 00	
95	1	CC EXT	xx	Check sum of bytes 64 - 94
96—255	160	Vendor specific		

Note: The "xx" byte should be filled in according to practical case. For more information, please refer to the related document of *SFP Multi-Source Agreement (MSA)*.

Recommended Host Board Power Supply Circuit

Figure 1 shows the recommended host board power supply circuit.

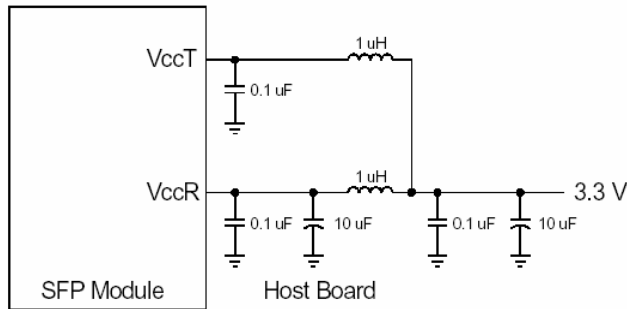

Figure 1, Recommended Host Board Power Supply Circuit

Recommended Interface Circuit

Figure 2 shows the recommended interface circuit.

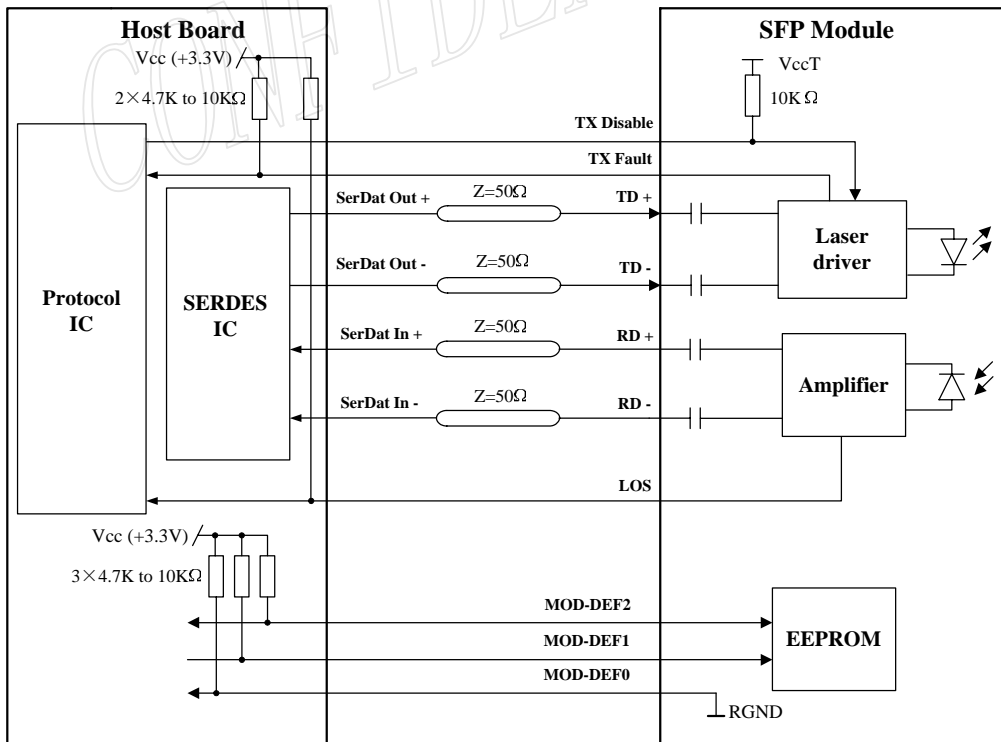

Figure 2, Recommended Interface Circuit

Pin Definitions

Figure 3 below shows the pin numbering of SFP electrical interface. The pin functions are described in Table 8 with some accompanying notes.

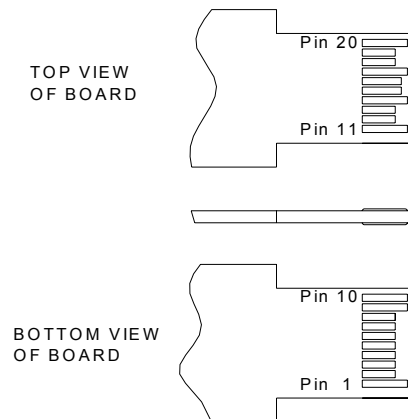

Figure 3, Pin View

Table 8– Pin Function Definitions

Pin No.	Name	Function	Plug Seq.	Notes
1	VeeT	Transmitter Ground	1	
2	TX Fault	Transmitter Fault Indication	3	Note 1
3	TX Disable	Transmitter Disable	3	Note 2
4	MOD-DEF2	Module Definition 2	3	Note 3
5	MOD-DEF1	Module Definition 1	3	Note 3
6	MOD-DEF0	Module Definition 0	3	Note 3
7	Rate Select	Not Connected	3	
8	LOS	Loss of Signal	3	Note 4
9	VeeR	Receiver Ground	1	
10	VeeR	Receiver Ground	1	
11	VeeR	Receiver Ground	1	
12	RD-	Inv. Received Data Out	3	Note 5
13	RD+	Received Data Out	3	Note 5
14	VeeR	Receiver Ground	1	
15	VccR	Receiver Power	2	
16	VccT	Transmitter Power	2	
17	VeeT	Transmitter Ground	1	
18	TD+	Transmit Data In	3	Note 6
19	TD-	Inv. Transmit Data In	3	Note 6
20	VeeT	Transmitter Ground	1	

Notes:

- TX Fault is an open collector output, which should be pulled up with a 4.7k~10kΩ resistor on the host board to a voltage between 2.0V and Vcc+0.3V. Logic 0 indicates normal operation; logic 1 indicates a laser fault of some kind. In the low state, the output will be pulled to less than 0.8V.
- TX Disable is an input that is used to shut down the transmitter optical output. It is pulled up within the module with a 4.7k~10kΩ resistor. Its states are:
 Low (0~0.8V): Transmitter on

- ($>0.8V$, $<2.0V$): Undefined
 - High ($2.0\sim 3.465V$): Transmitter Disabled
 - Open: Transmitter Disabled
3. MOD-DEF 0,1,2 are the module definition pins. They should be pulled up with a $4.7k\sim 10k\Omega$ resistor on the host board. The pull-up voltage shall be V_{ccT} or V_{ccR} .
 MOD-DEF 0 grounded by the module indicates that the module is present
 MOD-DEF 1 is the clock line of two-wire serial interface for serial ID
 MOD-DEF 2 is the data line of two-wire serial interface for serial ID
 4. LOS is an open collector output, which should be pulled up with a $4.7k\sim 10k\Omega$ resistor on the host board to a voltage between $2.0V$ and $V_{cc}+0.3V$. Logic 0 indicates normal operation; logic 1 indicates loss of signal. In the low state, the output will be pulled to less than $0.8V$.
 5. These are the differential receiver outputs. They are internally AC-coupled 100Ω differential lines which should be terminated with 100Ω (differential) at the user SERDES.
 6. These are the differential transmitter inputs. They are AC-coupled, differential lines with 100Ω differential termination inside the module.

Mechanical Design Diagram

The mechanical design diagram is shown in Figure 4.

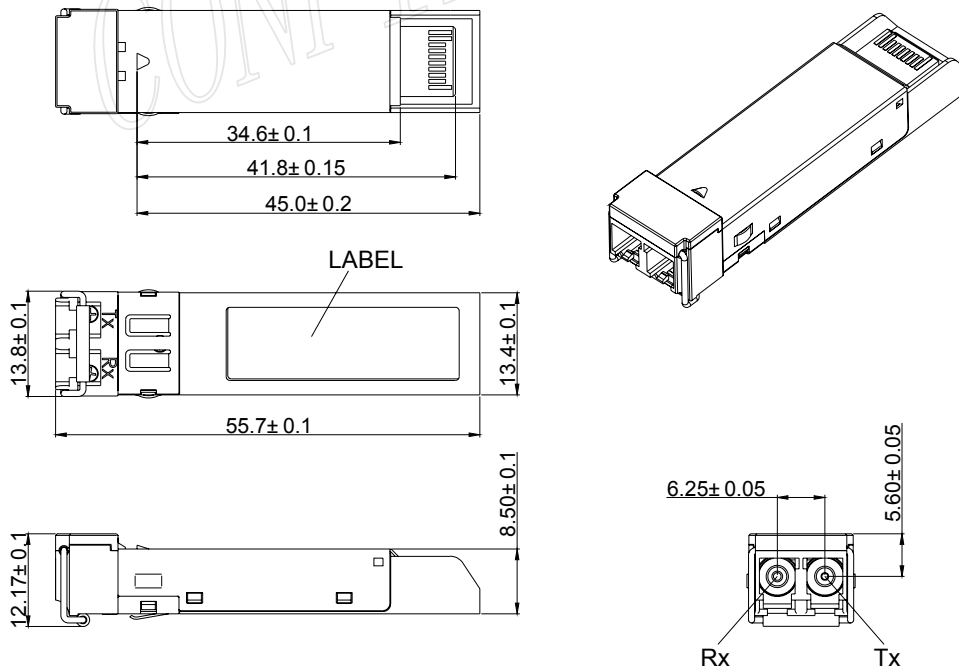
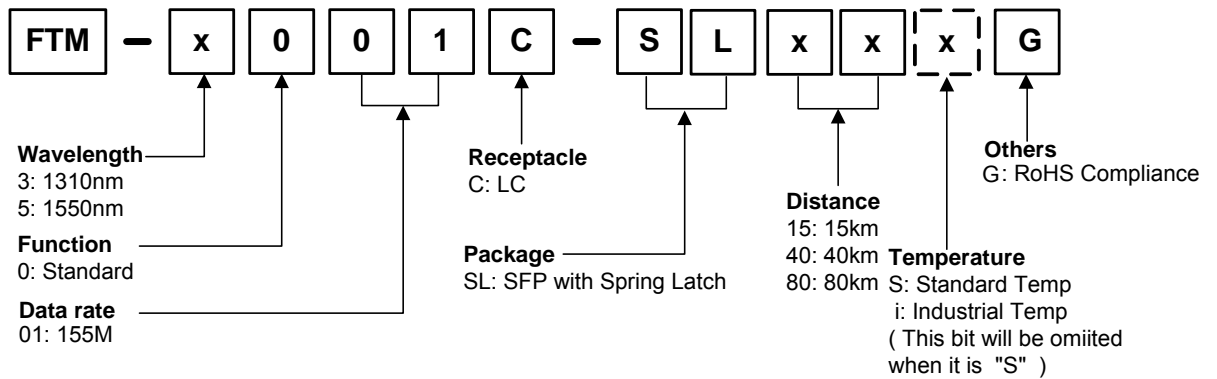

Figure 4, Mechanical Design Diagram of the SFP with Spring-Latch

Ordering information



Part No.	Product Description
FTM-3001C-SL15G	1310nm, 155Mbps, 15km, SFP with spring latch, 0°C~+70°C,RoHS compliance
FTM-3001C-SL15iG	1310nm, 155Mbps, 15km, SFP with spring latch, -40°C~+85°C,RoHS compliance
FTM-3001C-SL40G	1310nm, 155Mbps, 40km, SFP with spring latch, 0°C~+70°C,RoHS compliance
FTM-3001C-SL40iG	1310nm, 155Mbps, 40km, SFP with spring latch, -40°C~+85°C,RoHS compliance
FTM-5001C-SL80G	1550nm, 155Mbps, 80km, SFP with spring latch, 0°C~+70°C,RoHS compliance

Related Documents

For further information, please refer to the following documents:

- *Fiberxon Spring-Latch SFP Installation Guide*
- *Fiberxon SFP Application Notes*
- *SFP Multi-Source Agreement (MSA)*

Obtaining Document

You can visit our website:

<http://www.fiberxon.com>

Or contact Fiberxon, Inc. America Sales Office listed at the end of the documentation to get the latest documents.

Revision History

Revision	Initiate	Review	Approve	Subject	Release Date
Rev. 1a	Solaris Zhu	Monica Wei	Walker.Weii	Initial datasheet	Dec 23, 2005
Rev. 1b	Solaris Zhu	Monica Wei	Walker.Weii	Modified the recommended circuit; Updated overload value to -8dBm	Mar 15, 2006
Rev. 1c	Solaris Zhu	Monica Wei	Walker.Weii	Deleted FTM-5001C-SL80iG	May 12, 2006

				and updated datasheet from preliminary version to formal version	
--	--	--	--	--	--

© Copyright Fiberxon Inc. 2006

All Rights Reserved.

All information contained in this document is subject to change without notice. The products described in this document are NOT intended for use in implantation or other life support applications where malfunction may result in injury or death to persons.

The information contained in this document does not affect or change Fiberxon product specifications or warranties. Nothing in this document shall operate as an express or implied license or indemnity under the intellectual property rights of Fiberxon or third parties. All information contained in this document was obtained in specific environments, and is presented as an illustration. The results obtained in other operating environment may vary.

THE INFORMATION CONTAINED IN THIS DOCUMENT IS PROVIDED ON AN "AS IS" BASIS. In no event will Fiberxon be liable for damages arising directly from any use of the information contained in this document.

Contact

U.S.A. Headquarter:

5201 Great America Parkway, Suite 350

Santa Clara, CA 95054

U. S. A.

Tel: 408-562-6288

Fax: 408-562-6289

Or visit our website: <http://www.fiberxon.com>

CONFIDENTIAL