

8 Pin Triple TTL Compatible Active Delay Lines

Delay Time ±5% or ±2nS†	DIP Part Number	SMD-G Part Number	SMD-J Part Number	Delay Time ±5% or ±2nS†	DIP Part Number	SMD-G Part Number	SMD-J Part Number
5	EPA249-5	EPA249G-5	EPA249J-5	23	EPA249-23	EPA249G-23	EPA249J-23
6	EPA249-6	EPA249G-6	EPA249J-6	24	EPA249-24	EPA249G-24	EPA249J-24
7	EPA249-7	EPA249G-7	EPA249J-7	25	EPA249-25	EPA249G-25	EPA249J-25
8	EPA249-8	EPA249G-8	EPA249J-8	30	EPA249-30	EPA249G-30	EPA249J-30
9	EPA249-9	EPA249G-9	EPA249J-9	35	EPA249-35	EPA249G-35	EPA249J-35
10	EPA249-10	EPA249G-10	EPA249J-10	40	EPA249-40	EPA249G-40	EPA249J-40
11	EPA249-11	EPA249G-11	EPA249J-11	45	EPA249-45	EPA249G-45	EPA249J-45
12	EPA249-12	EPA249G-12	EPA249J-12	50	EPA249-50	EPA249G-50	EPA249J-50
13	EPA249-13	EPA249G-13	EPA249J-13	55	EPA249-55	EPA249G-55	EPA249J-55
14	EPA249-14	EPA249G-14	EPA249J-14	60	EPA249-60	EPA249G-60	EPA249J-60
15	EPA249-15	EPA249G-15	EPA249J-15	65	EPA249-65	EPA249G-65	EPA249J-65
16	EPA249-16	EPA249G-16	EPA249J-16	70	EPA249-70	EPA249G-70	EPA249J-70
17	EPA249-17	EPA249G-17	EPA249J-17	75	EPA249-75	EPA249G-75	EPA249J-75
18	EPA249-18	EPA249G-18	EPA249J-18	80	EPA249-80	EPA249G-80	EPA249J-80
19	EPA249-19	EPA249G-19	EPA249J-19	85	EPA249-85	EPA249G-85	EPA249J-85
20	EPA249-20	EPA249G-20	EPA249J-20	90	EPA249-90	EPA249G-90	EPA249J-90
21	EPA249-21	EPA249G-21	EPA249J-21	95	EPA249-95	EPA249G-95	EPA249J-95
22	EPA249-22	EPA249G-22	EPA249J-22	100	EPA249-100	EPA249G-100	EPA249J-100

† Whichever is greater. Delay Times referenced from input to leading edges at 25°C, 5.0V, with no load.

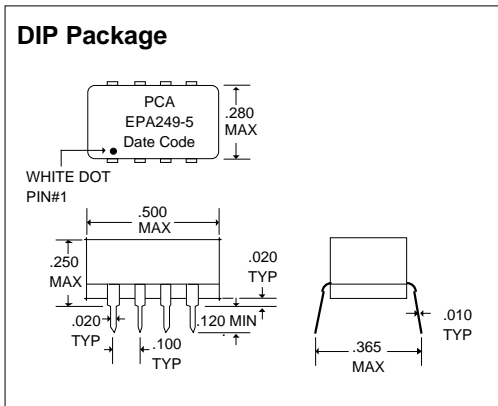

DC Electrical Characteristics

Parameter	Test Conditions	Min	Max	Unit
V _{OH}	High-Level Output Voltage	V _{CC} = min. V _{IL} = max. I _{OH} = max	2.7	V
V _{OL}	Low-Level Output Voltage	V _{CC} = min. V _{IH} = min. I _{OL} = max	0.5	V
V _{IK}	Input Clamp Voltage	V _{CC} = min. I _I = I _{IK}	-1.2V	V
I _{IH}	High-Level Input Current	V _{CC} = max. V _{IN} = 2.7V	50	µA
		V _{CC} = max. V _{IN} = 5.25V	1.0	mA
I _{IL}	Low-Level Input Current	V _{CC} = max. V _{IN} = 0.5V	-2	mA
I _{OS}	Short Circuit Output Current	V _{CC} = max. V _{OUT} = 0. (One output at a time)	-40	mA
I _{CCH}	High-Level Supply Current	V _{CC} = max. V _{IN} = OPEN	115	mA
I _{CCL}	Low-Level Supply Current	V _{CC} = max. V _{IN} = 0	115	mA
T _{RO}	Output Rise Time		4	nS
N _H	Fanout High-Level Output	V _{CC} = max. V _{OH} = 2.7V	20	TTL LOAD
N _L	Fanout Low-Level Output	V _{CC} = max. V _{OL} = 0.5V	10	TTL LOAD

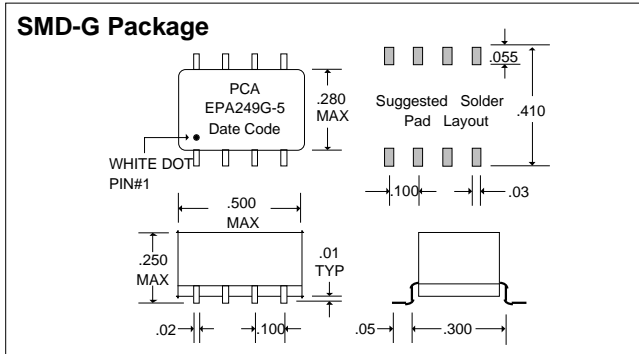

Recommended Operating Conditions

*These two values are inter-dependent.

Parameter	Min	Max	Unit
V _{CC}	4.75	5.25	V
V _{IH}	2.0		V
V _{IL}		0.8	V
I _{IK}		-18	mA
I _{OH}		-1.0	mA
I _{OL}		20	mA
PW*	40		%
d*		40	%
T _A	0	+70	°C

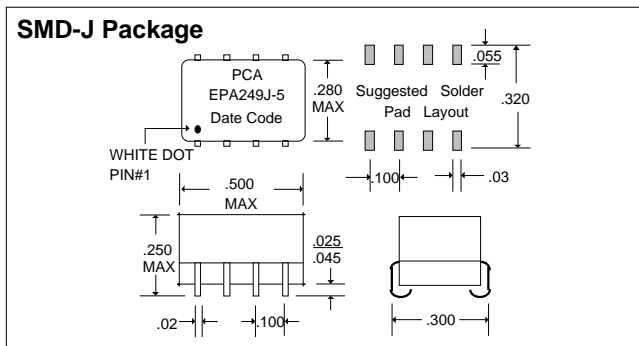

Input Pulse Test Conditions @ 25° C

Parameter	Unit
E _{IN}	3.2 Volts
PW	110 %
T _{RI}	2.0 nS
PRR	1.0 MHz
V _{CC}	5.0 Volts

