

Compensated High Current Choke, 3-phase



**Description**

- Current compensated choke
- 3-phase choke
- THT-terminals
- Flange for mounting onto printed circuit board
- Fully potted resin

**Standards**

- EN 60938
- IEC 60950
- EN 55011/55014
- VDE 0871/0875

**Applications**

- Placed in front of frequency converter
- Stepper motor drives
- UPS-systems
- Inverter

**References**

[General Product Information](#)

**Weblinks**

[Approvals](#), [RoHS](#), [CHINA-RoHS](#), [e-Store](#), [Distributor-Stock-Check](#)

**Technical Data**

Rated voltage	up to 540 VAC
Rated voltage	up to 760 VDC
Rated Current	10 - 20A @ Ta 40 °C
Rated inductance	0.6 - 5 mH, Tol. -30% +50%
Power Operating Frequency	50 - 400Hz
Terminal technic	THT
Weight	146 - 517g
Material: Housing	UL 94V-0
Sealing Compound	UL 94V-0

Test Voltage	2.5 kV, 50Hz, 2 sec, winding to winding
Isolation Voltage	2.5 kV eff., 50Hz, 2 sec, winding to ambient
Climatic Category	25/100/21 acc. to IEC 60068-1
Allowable Operation Temp.	-25 °C to 100 °C

**Dimensions**

Case 31-3P

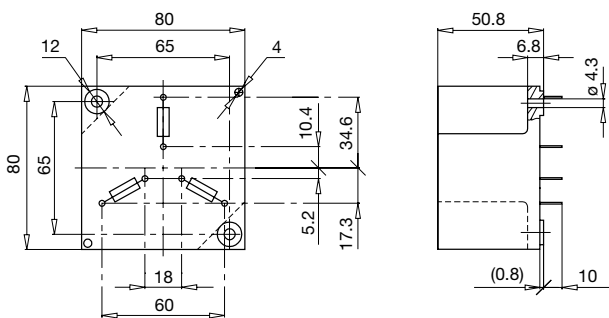

Case 46-3P

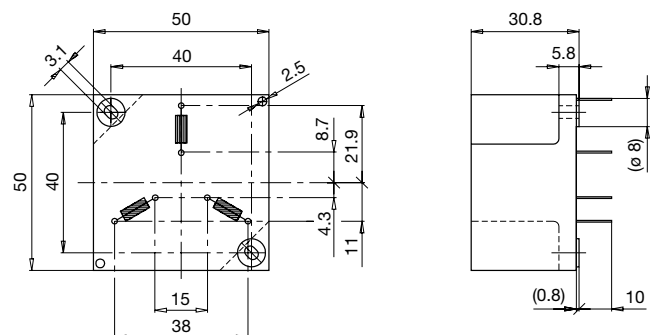

## Variants

$I_n$ [A]	$L_n$ [mH]	$R_{cu}$ [mΩ]	Tripped Power Dissipation [W]	$f_{RES}$ [MHz]	Copper ø [mm]	Weight [g]	Housing	Packing unit [pcs.]	Order Number
10	5	32	9.6	0.22	1.25	501	31-3P	2	DKIL-0331-1005
15	2	13	8.8	0.44	1.6	497	31-3P	2	DKIL-0331-1502
20	1	8	9.6	0.68	1.8	517	31-3P	2	DKIL-0331-2001
10	2.5	15	4.5	0.5	1.25	146	46-3P	10	DKIL-0346-1002
15	1	7	4.7	0.6	1.6	148	46-3P	10	DKIL-0346-1501
20	0.6	5	6	2.6	1.8	155	46-3P	10	DKIL-0346-20D6