

Memory FRAM

CMOS

256 K (32 K × 8) Bit SPI

MB85RS256

■ DESCRIPTION

MB85RS256 is a FRAM (Ferroelectric Random Access Memory) chip in a configuration of 32,768 words × 8 bits, using the ferroelectric process and silicon gate CMOS process technologies for forming the nonvolatile memory cells.

MB85RS256 adopts the Serial Peripheral Interface (SPI).

Unlike SRAM, MB85RS256 is able to retain data without back-up battery.

The memory cells used for the MB85RS256 has improved at least 10^{10} times of read/write operation significantly outperforming Flash memory and E²PROM in the number.

MB85RS256 does not take long time to write data unlike Flash memories nor E²PROM, and MB85RS256 takes no wait time.

■ FEATURES

- Bit configuration : 32,768 × 8 bits
- Operating power supply voltage : 3.0 V to 3.6 V
- Operating frequency : 15 MHz (Max)
- Serial Peripheral Interface : SPI (Serial Peripheral Interface)
Correspondent to SPI mode 0 (0, 0) and mode 3 (1, 1)
- Operating temperature range : -20 °C to +85 °C
- Data retention : 10 years (+55 °C)
- High endurance 10 Billion Read/writes (Min)
- Package : 8-pin plastic SOP (FPT-8P-M02)

MB85RS256

■ PIN ASSIGNMENT

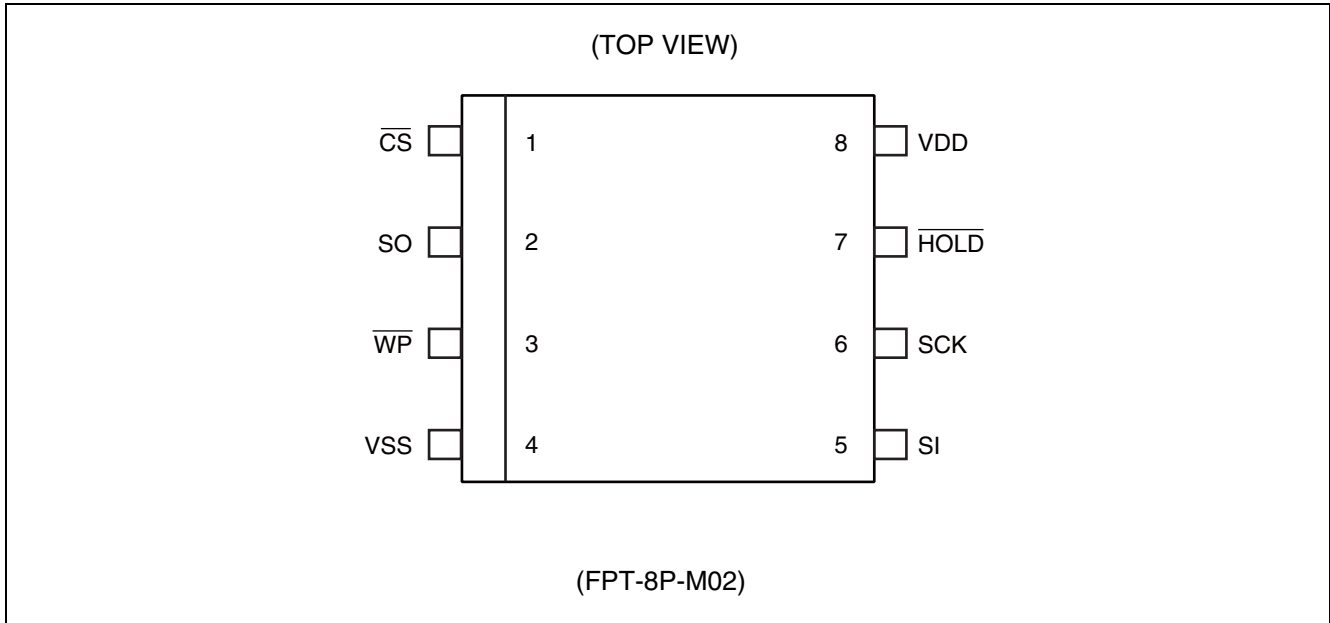

■ PIN FUNCTIONAL DESCRIPTIONS

Pin No.	Pin Name	Functional description
1	\overline{CS}	Chip Select This is an input pin to make chips select. When \overline{CS} is "H", device is in deselect (standby) status as long as device is not write status internally, and SO becomes High-Z. Other inputs from pins are ignored for this time. When \overline{CS} is "L", device is in select (active) status. \overline{CS} has to be "L" before inputting op-code.
3	\overline{WP}	Write Protect This is a pin to control writing to a status register. When \overline{WP} is "L", writing to a status register is not operated.
7	\overline{HOLD}	Hold This pin is used to interrupt serial input/output without making chips deselect. When \overline{HOLD} is "L", hold operation is activated, SO becomes High-Z, SCK and SI become don't care. While the hold operation, \overline{CS} has to be retained "L".
6	SCK	Serial Clock This is a clock input pin to input/output serial data. SI is loaded synchronously to a rising edge, SO is output synchronously to a falling edge.
5	SI	Serial Data Input This is an input pin of serial data. This inputs op-code, address, and writing data.
2	SO	Serial Data Output This is an output pin of serial data. Reading data of FRAM memory cell array and status register data are output. This is High-Z during standby.
8	VDD	Supply Voltage
4	VSS	Ground

■ BLOCK DIAGRAM

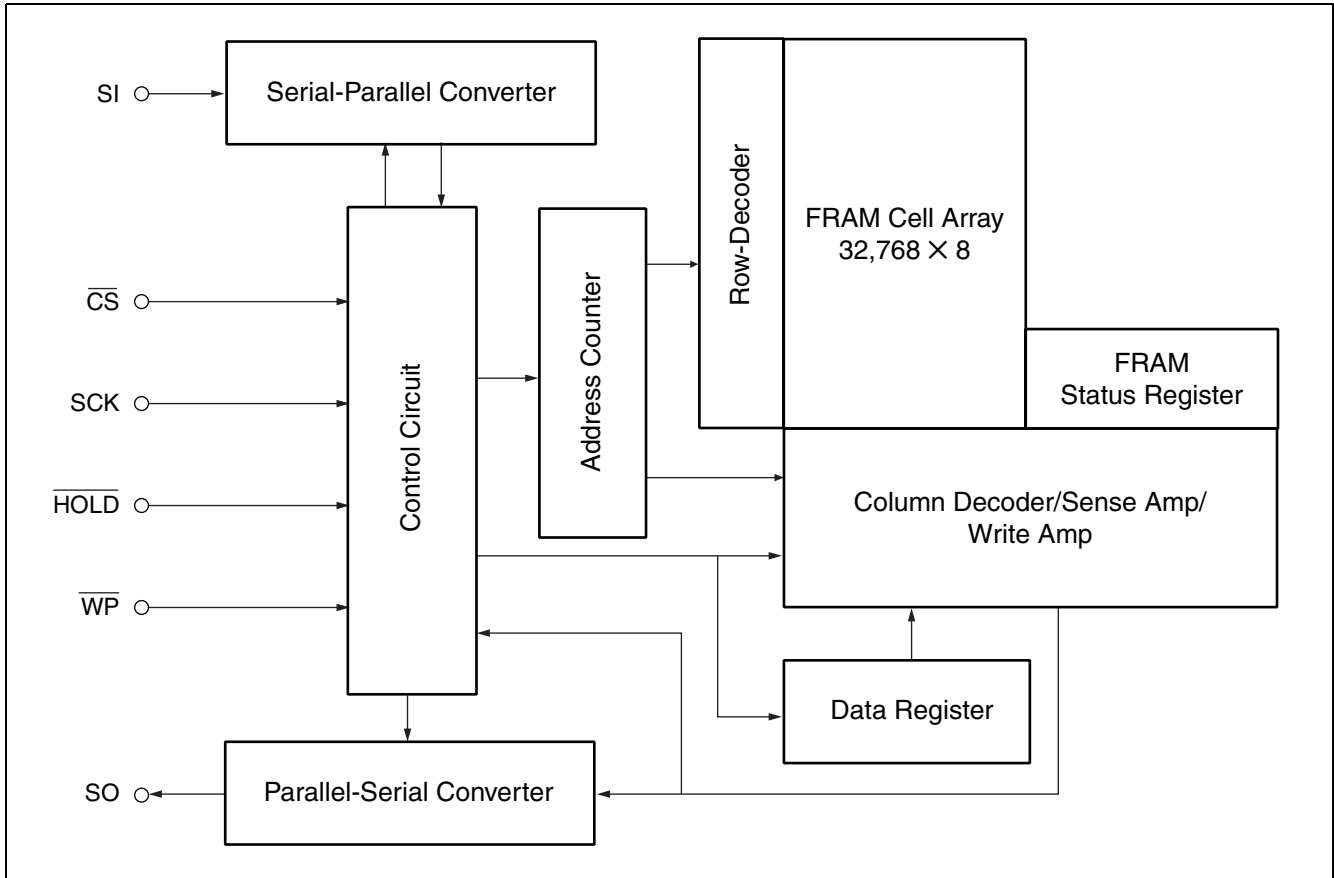

MB85RS256

■ SPI MODE

MB85RS256 is corresponding to the SPI mode 0 (CPOL = 0, CPHA = 0), and SPI mode 3 (CPOL = 1, CPHA = 1).

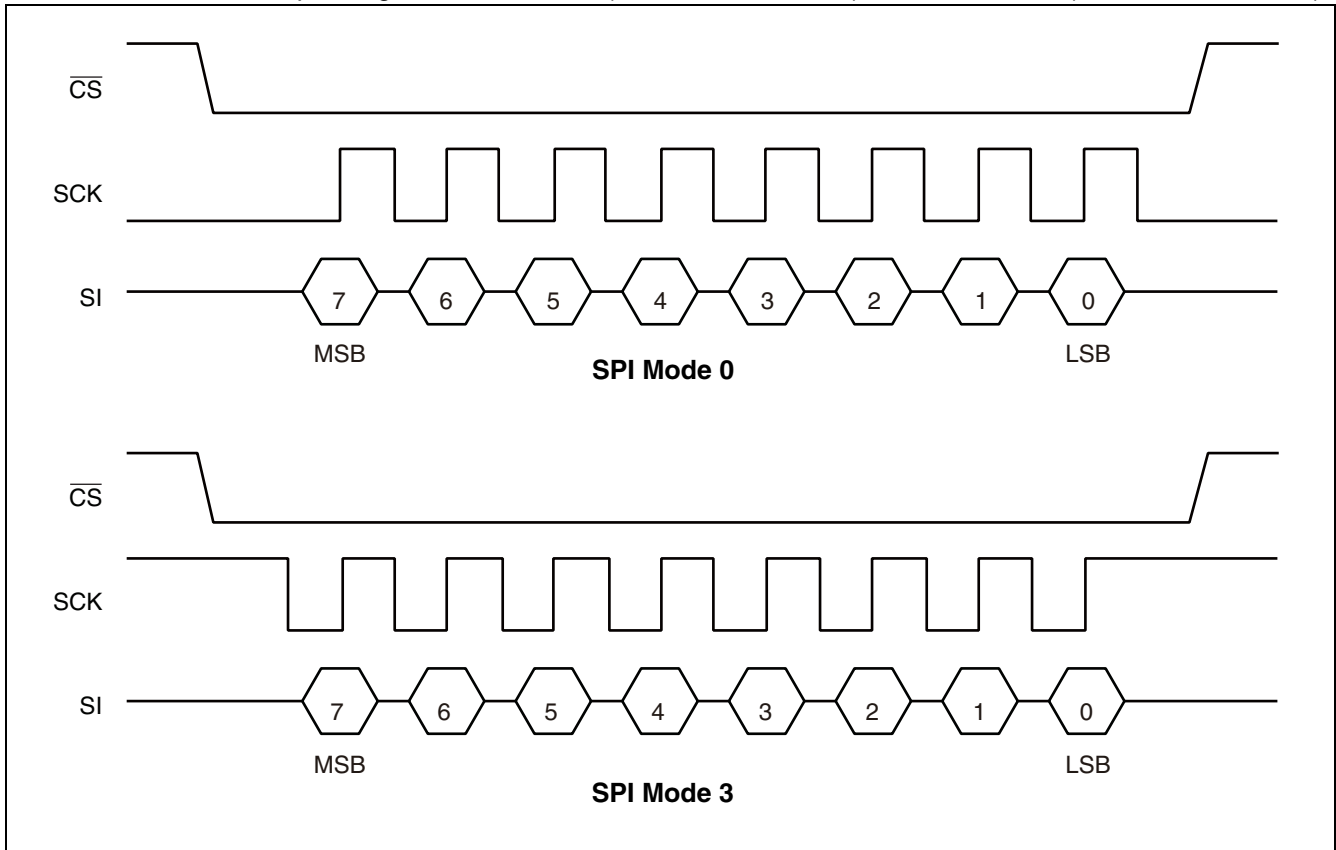

■ SERIAL PERIPHERAL INTERFACE (SPI)

MB85RS256 works as a slave of SPI. More than 2 devices can be connected by using microcontroller equipped with SPI port. By using a microcontroller not equipped with SPI port, SI and SO can be bus connected to use.

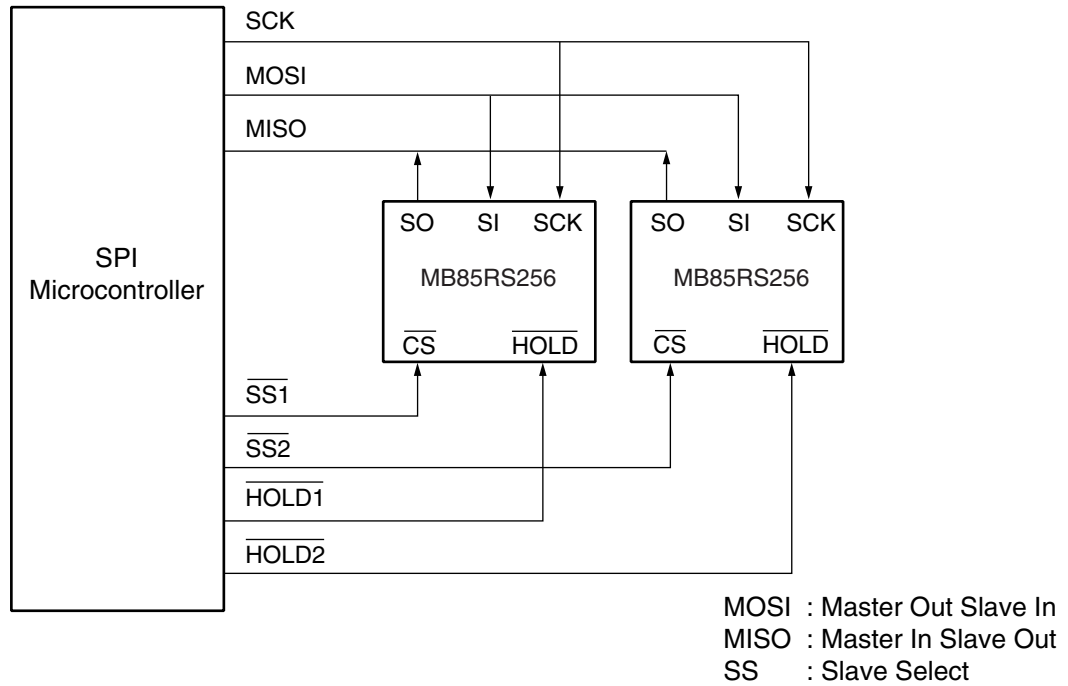

System Configuration with SPI Port

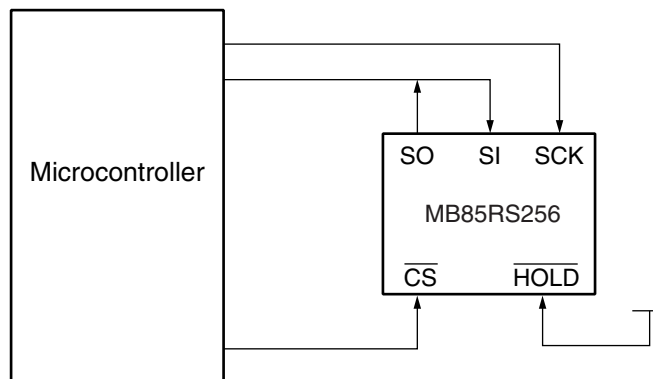

System Configuration without SPI Port

MB85RS256

■ STATUS REGISTER

Bit No.	Bit Name	Function
7	WPEN	Status Register Write Protect This is a bit composed of nonvolatile memories (FRAM). WPEN is related to \overline{WP} input to protect writing to a status register (refer to “■ WRITING PROTECT”). Writing with the WRSR command and reading with the RDSR command are possible.
6 to 4	—	Not Used Bits These are bits composed of nonvolatile memories, writing with the WRSR command is possible, and “000” is written before shipment. These bits are not used but they are read with the RDSR command.
3	BP1	Block Protect This is a bit composed of nonvolatile memory (FRAM). This defines block size for writing protect with the WRITE command (refer to “■ BLOCK PROTECT”). Writing with the WRSR command and reading with the RDSR command are possible.
2	BP0	
1	WEL	Write Enable Latch This indicates FRAM memory and status register are writable. The WREN command is for setting, and the WRDI command is for resetting. With the RDSR command, reading is possible but writing is not possible with the WRSR command. WEL is reset after the following operations. The time when power is up. The time when the WRDI command is input. The time when the WRSR command is input. The time when the WRITE command is input.
0	0	This is a bit fixed to “0”.

■ OP-CODE

MB85RS256 accepts 6 kinds of command specified in op-code. Op-code is a code composed of 8 bits shown in the table below. When invalid codes other than codes below are input, they are ignored. If \overline{CS} is risen while inputting op-code, the command are not performed.

Name	Description	Op-code
WREN	Set Write Enable Latch	0000 0110 _B
WRDI	Reset Write Enable Latch	0000 0100 _B
RDSR	Read Status Register	0000 0101 _B
WRSR	Write Status Register	0000 0001 _B
READ	Read Memory Code	0000 0011 _B
WRITE	Write Memory Code	0000 0010 _B

■ COMMAND

• WREN

The WREN command sets WEL (Write Enable Latch) . WEL has to be set with the WREN command before writing operation (WRSR command and WRITE command) .

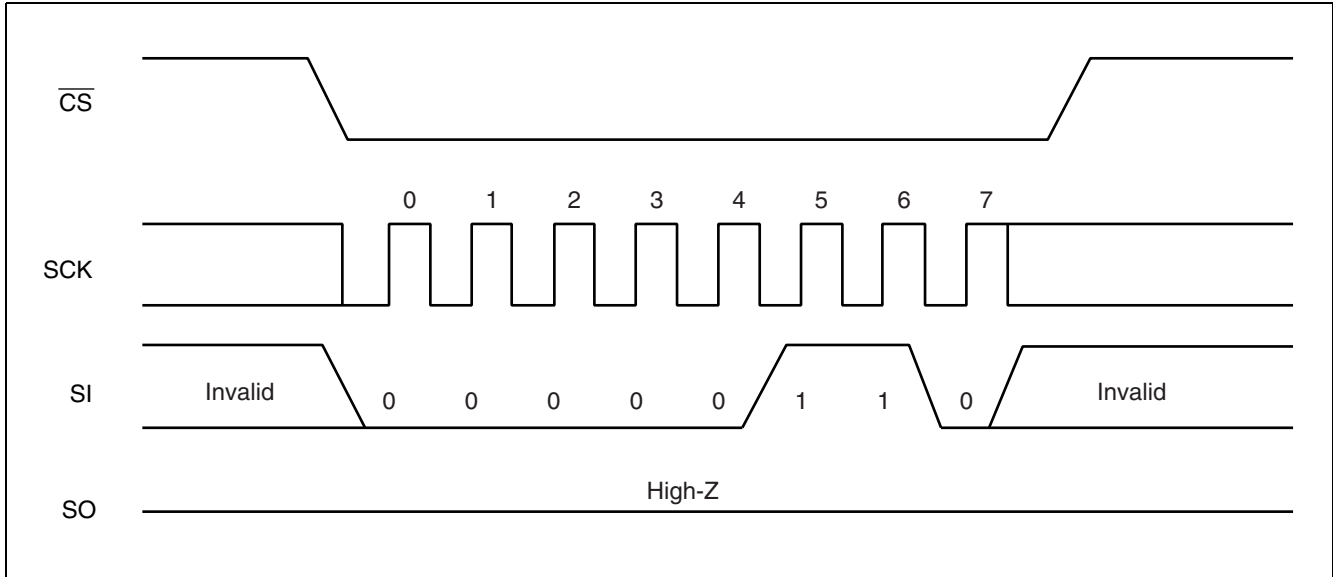

• WRDI

The WRDI command resets WEL (Write Enable Latch) . Writing operation (WRITE command and WRSR command) are not performed when WEL is reset.

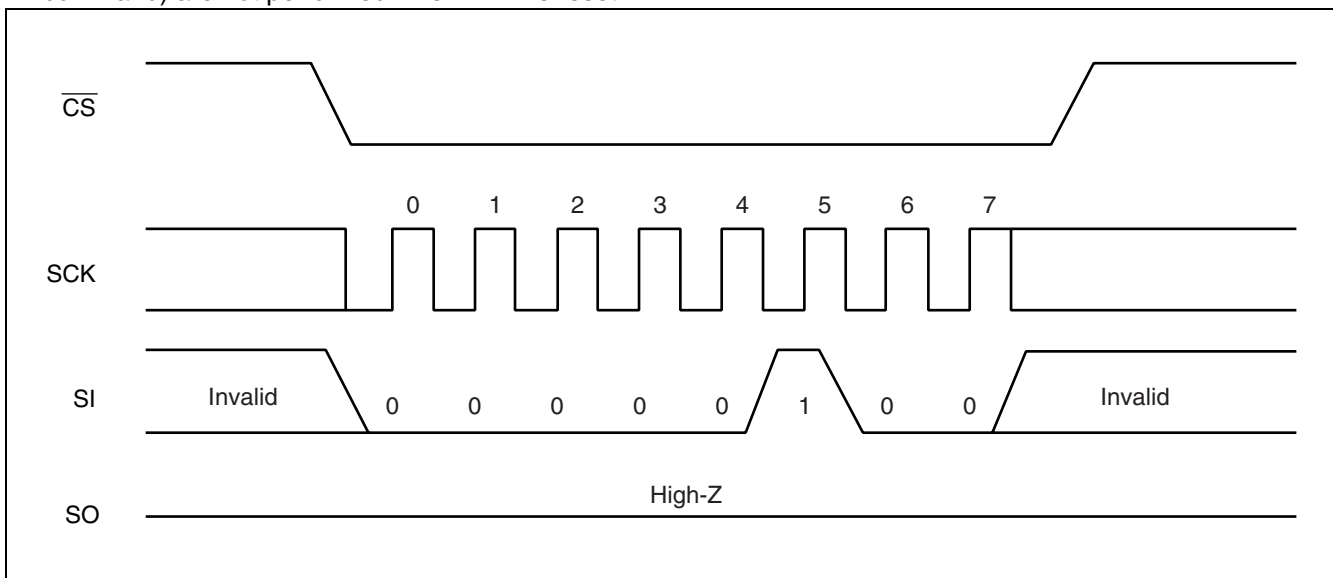

MB85RS256

• RDSR

The RDSR command reads status register data. After op-code of RDSR is input to SI, 8-cycle clock is input to SCK. The SI value is invalid for this time. SO is output synchronously to a falling edge of SCK. Continuously reading status register is enabled by keep on sending SCK before rising \overline{CS} with the RDSR command.

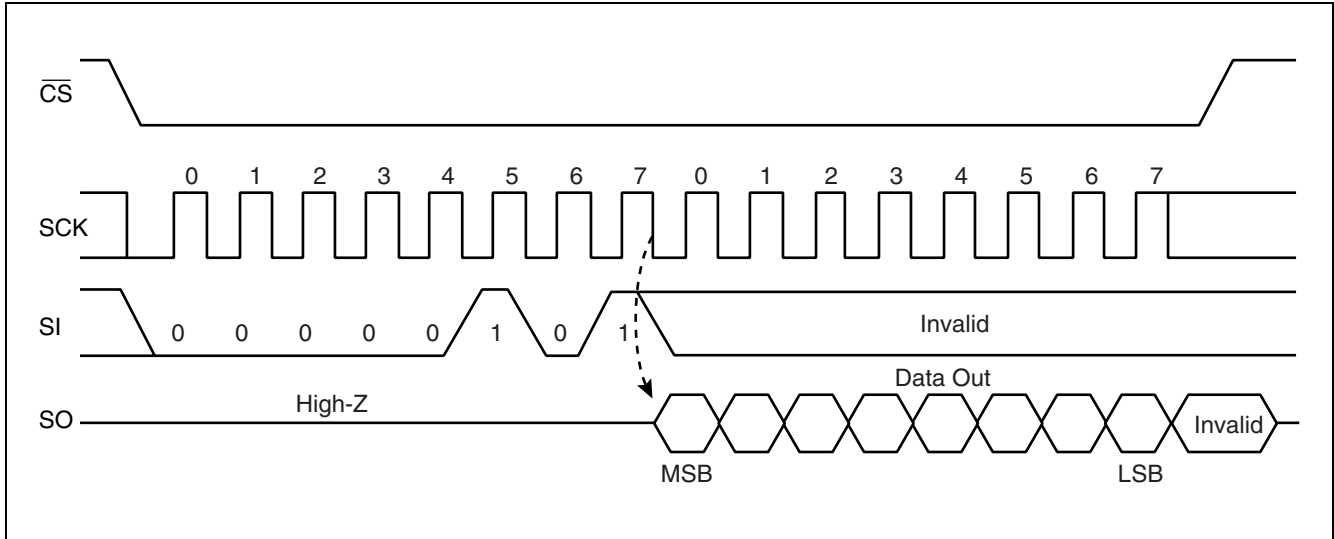

• WRSR

The WRSR command writes data to the nonvolatile memory bit of status register. After performing WRSR op-code to a SI pin, 8 bits writing data is input. WEL (Write Enable Latch) is not able to be written with WRSR command. a SI value correspondent to bit 1 is ignored. Bit 0 of the status register is fixed to "0" and cannot be written. The SI value corresponding to bit 0 is ignored.

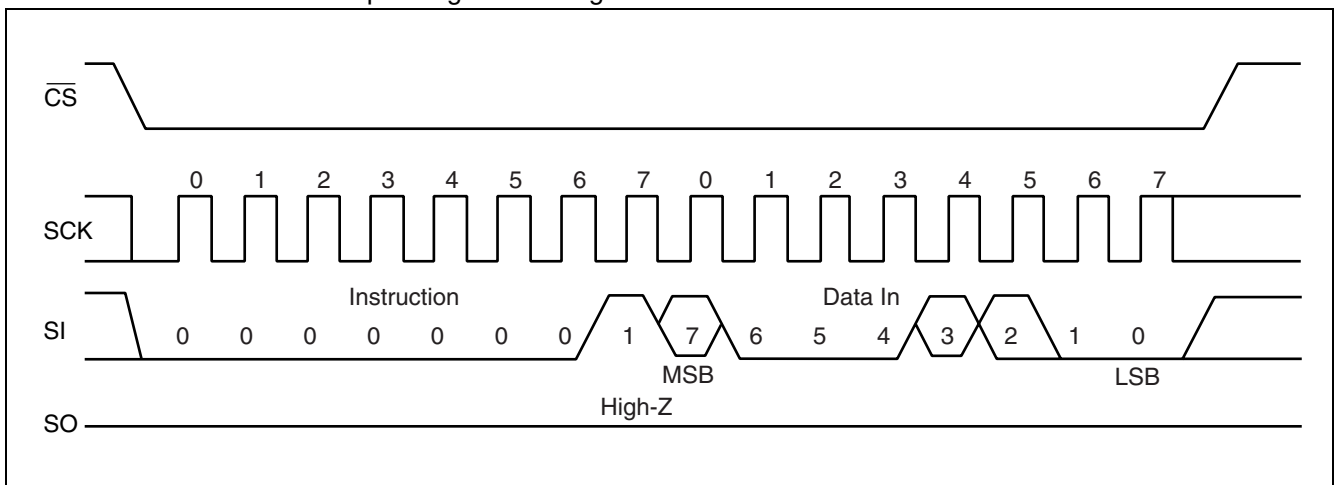

• READ

The READ command reads FRAM memory cell array data. Arbitrary 16 bits address and op-code of READ are input to SI. The most significant address bit is invalid. Then, 8-cycle clock is input to SCK. SO is output synchronously to the falling edge of SCK. While reading, the SI value is invalid. When \overline{CS} is risen, the READ command is completed, but keep on reading address with automatic increment is enabled by continuously sending clock for 8 cycles each to SCK before \overline{CS} is risen. When it reaches the most significant address, it rolls over to come back to the starting address, and reading cycle keeps on infinitely.

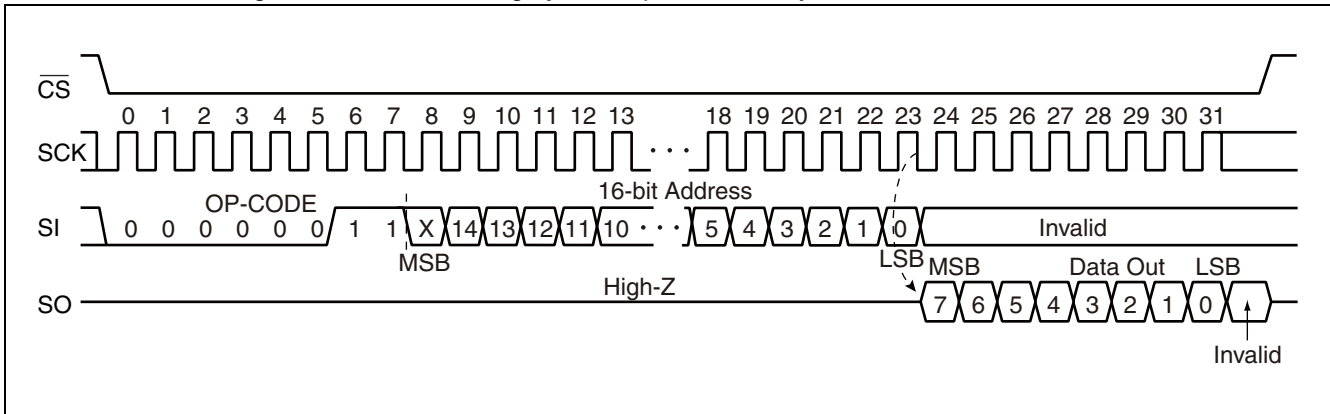

• WRITE

The WRITE command writes data to FRAM memory cell array. WRITE op-code, arbitrary 16 bits of address and 8 bits of writing data are input to SI. The most significant address bit is invalid. When 8 bits of writing data is input, data is written to FRAM memory cell array. Risen \overline{CS} will terminate the WRITE command, but if you continue sending the writing data for 8 bits each before \overline{CS} is risen, it is possible to continue writing with automatic address increment. When it reaches the most significant address, it rolls over, comes back to the starting address, and writing cycle can be continued infinitely.

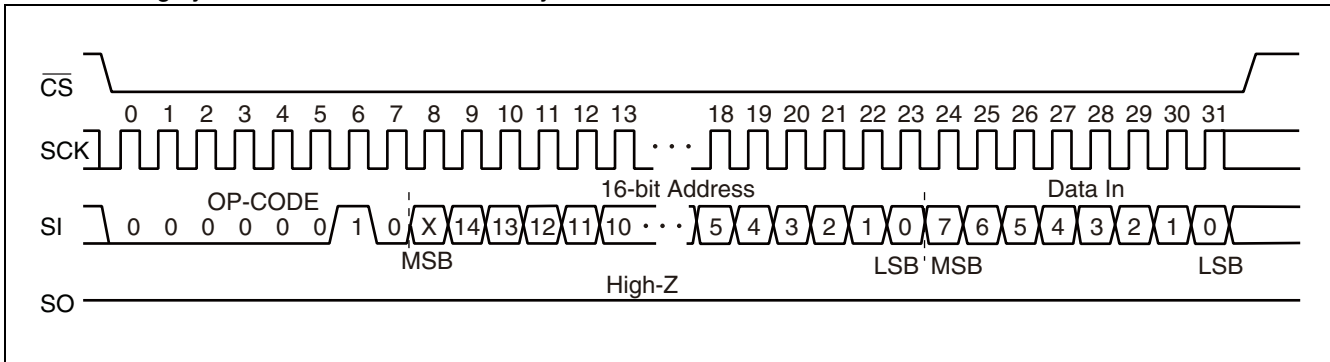

MB85RS256

■ BLOCK PROTECT

Writing protect block is configured by the WRITE command with BP1, BP0 value of the status register.

BP1	BP0	Protected Block
0	0	None
0	1	6000 _H to 7FFF _H (upper 1/4)
1	0	4000 _H to 7FFF _H (upper 1/2)
1	1	0000 _H to 7FFF _H (all)

■ WRITING PROTECT

Writing operation of the WRITE command and the WRSR command are protected with the value of WEL, WPEN, \overline{WP} as shown in the table.

WEL	WPEN	\overline{WP}	Protected Blocks	Unprotected Blocks	Status Register
0	X	X	Protected	Protected	Protected
1	0	X	Protected	Unprotected	Unprotected
1	1	0	Protected	Unprotected	Protected
1	1	1	Protected	Unprotected	Unprotected

■ HOLD OPERATION

Hold status is retained without aborting a command if \overline{HOLD} is "L" while \overline{CS} is "L". The timing for starting and ending hold status depends on the SCK to be "H" or "L" when a \overline{HOLD} pin input is transited as shown in the diagram below. Arbitrary command operation is interrupted in hold status, SCK and SI inputs become don't care. And, SO becomes High-Z while reading command (RDSR, READ). If \overline{CS} is risen with hold status, a command is aborted and device is reset.

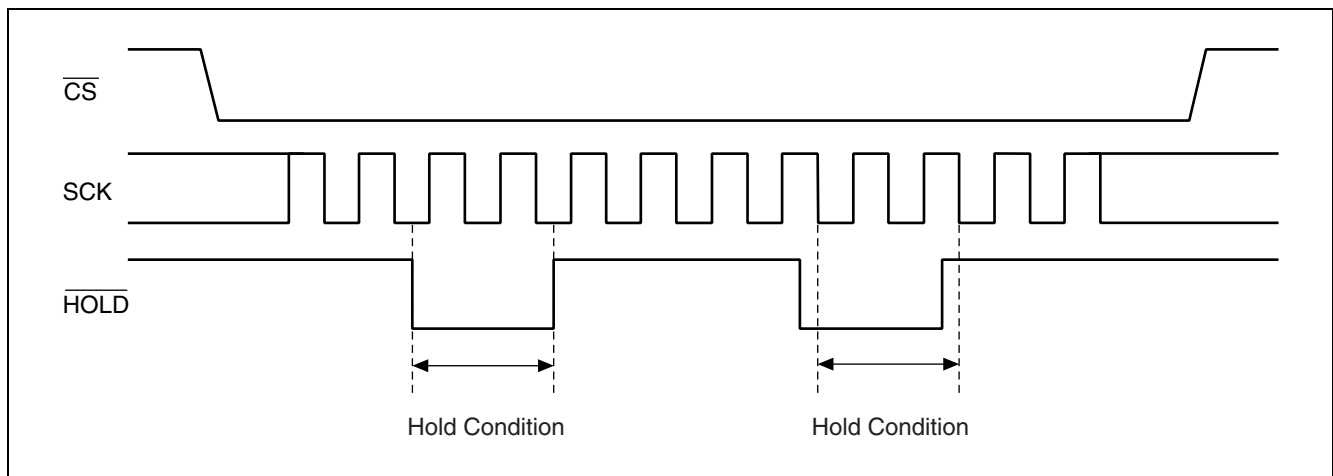

■ ABSOLUTE MAXIMUM RATINGS

Parameter	Symbol	Rating		Unit
		Min	Max	
Power supply voltage	V_{DD}	- 0.5	+ 4.0	V
Input voltage	V_{IN}	- 0.5	$V_{DD} + 0.5$	V
Output voltage	V_{OUT}	- 0.5	$V_{DD} + 0.5$	V
Operating temperature	T_A	- 20	+ 85	°C
Storage temperature	T_{stg}	- 20	+ 85	°C

WARNING: Semiconductor devices can be permanently damaged by application of stress (voltage, current, temperature, etc.) in excess of absolute maximum ratings. Do not exceed these ratings.

■ RECOMMENDED OPERATING CONDITIONS

Parameter	Symbol	Value			Unit
		Min	Typ	Max	
Power supply voltage	V_{DD}	3.0	3.3	3.6	V
Input high voltage	V_{IH}	$0.8 \times V_{DD}$	—	$V_{DD} + 0.5$	V
Input low voltage	V_{IL}	- 0.5	—	+ 0.6	V
Operating temperature	T_A	- 20	—	+ 85	°C

WARNING: The recommended operating conditions are required in order to ensure the normal operation of the semiconductor device. All of the device's electrical characteristics are warranted when the device is operated within these ranges.

Always use semiconductor devices within their recommended operating condition ranges. Operation outside these ranges may adversely affect reliability and could result in device failure.

No warranty is made with respect to uses, operating conditions, or combinations not represented on the data sheet. Users considering application outside the listed conditions are advised to contact their FUJITSU representatives beforehand.

MB85RS256

■ ELECTRICAL CHARACTERISTICS

1. DC Characteristics

(within recommended operating conditions)

Parameter	Symbol	Condition	Value			Unit
			Min	Typ	Max	
Input leakage current	I_{LI}	$V_{IN} = 0\text{ V to }V_{DD}$	—	—	10	μA
Output leakage current	I_{LO}	$V_{OUT} = 0\text{ V to }V_{DD}$	—	—	10	μA
Operating power supply current	I_{DD}	SCK = 15 MHz	—	5	10	mA
Standby current	I_{SB}	All inputs V_{SS} or SCK = SI = \overline{CS} = V_{DD}	—	3	50	μA
Output high voltage	V_{OH}	$I_{OH} = -0.1\text{ mA}$	$V_{DD} \times 0.8$	—	—	V
Output low voltage	V_{OL}	$I_{OL} = 2\text{ mA}$	—	—	0.4	V

2. AC Characteristics

(within recommended operating conditions)

Parameter	Symbol	Value		Unit
		Min	Max	
SCK clock frequency	f _{CK}	0	15	MHz
Clock high time	t _{CH}	30	—	ns
Clock low time	t _{CL}	30	—	ns
Chip select set up time	t _{CSU}	10	—	ns
Chip select hold time	t _{CSH}	10	—	ns
Output disable time	t _{OD}	—	20	ns
Output data valid time	t _{ODV}	—	35	ns
Output hold time	t _{OH}	0	—	ns
Deselect time	t _D	60	—	ns
Data in rise time	t _R	—	50	ns
Data fall time	t _F	—	50	ns
Data set up time	t _{SU}	5	—	ns
Data hold time	t _H	5	—	ns
$\overline{\text{HOLD}}$ set up time	t _{HS}	10	—	ns
$\overline{\text{HOLD}}$ hold time	t _{HH}	10	—	ns
$\overline{\text{HOLD}}$ output floating time	t _{HZ}	—	20	ns
$\overline{\text{HOLD}}$ output active time	t _{LZ}	—	20	ns

AC Test Condition

Power supply voltage : 3.0 V to 3.6 V
 Operation temperature : -20 °C to +85 °C
 Input voltage magnitude : 0.3 V to 2.7 V
 Input rise time : 5 ns
 Input fall time : 5 ns
 Input judge level : V_{DD}/2
 Output judge level : V_{DD}/2

MB85RS256

AC Load Equivalent Circuit

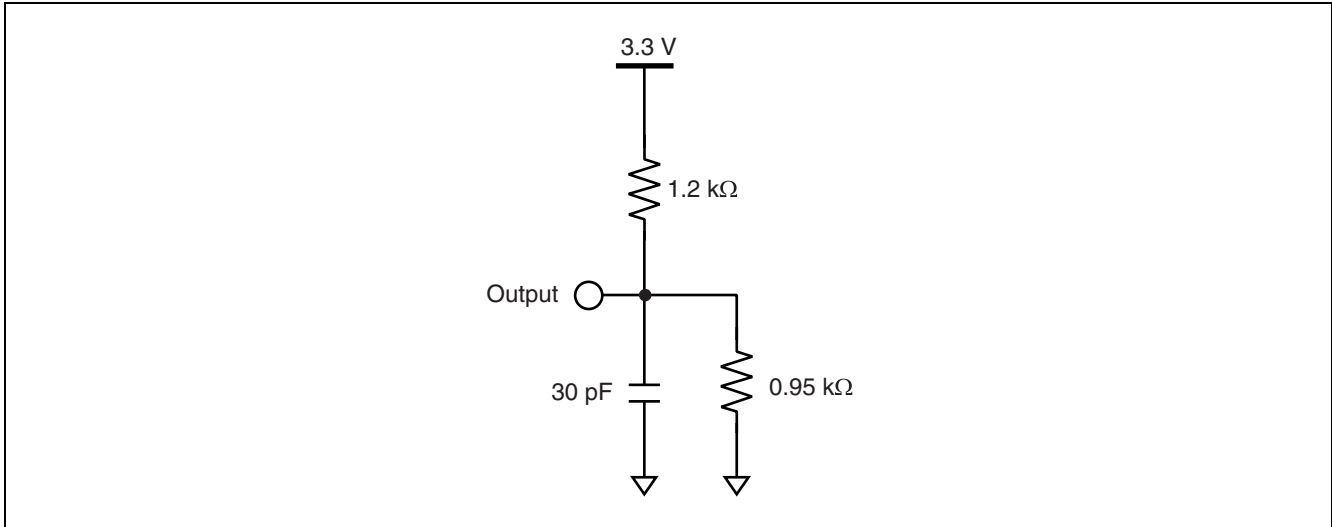

3. Pin Capacitance

Parameter	Symbol	Value		Unit
		Min	Max	
Output capacitance	C_o	—	10	pF
Input capacitance	C_i	—	10	pF

■ TIMING DIAGRAM

• Serial Data Timing

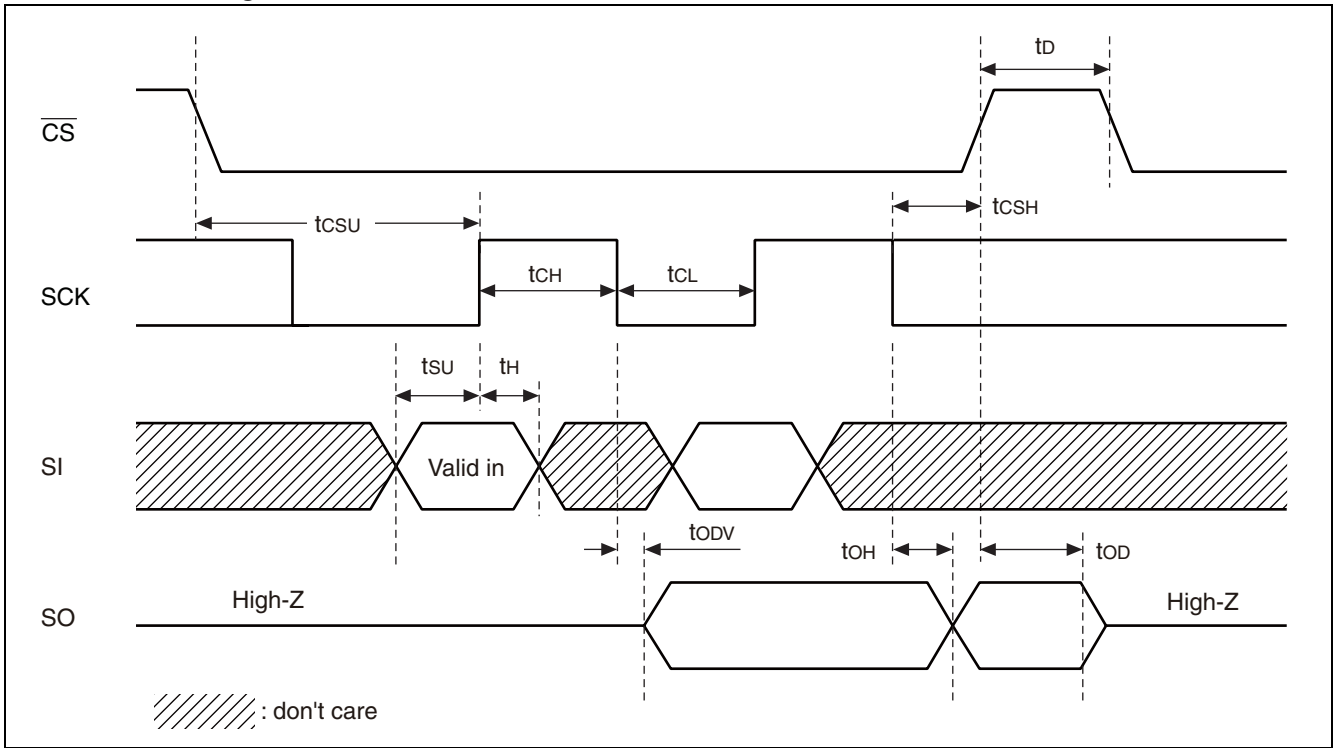

• Hold Timing

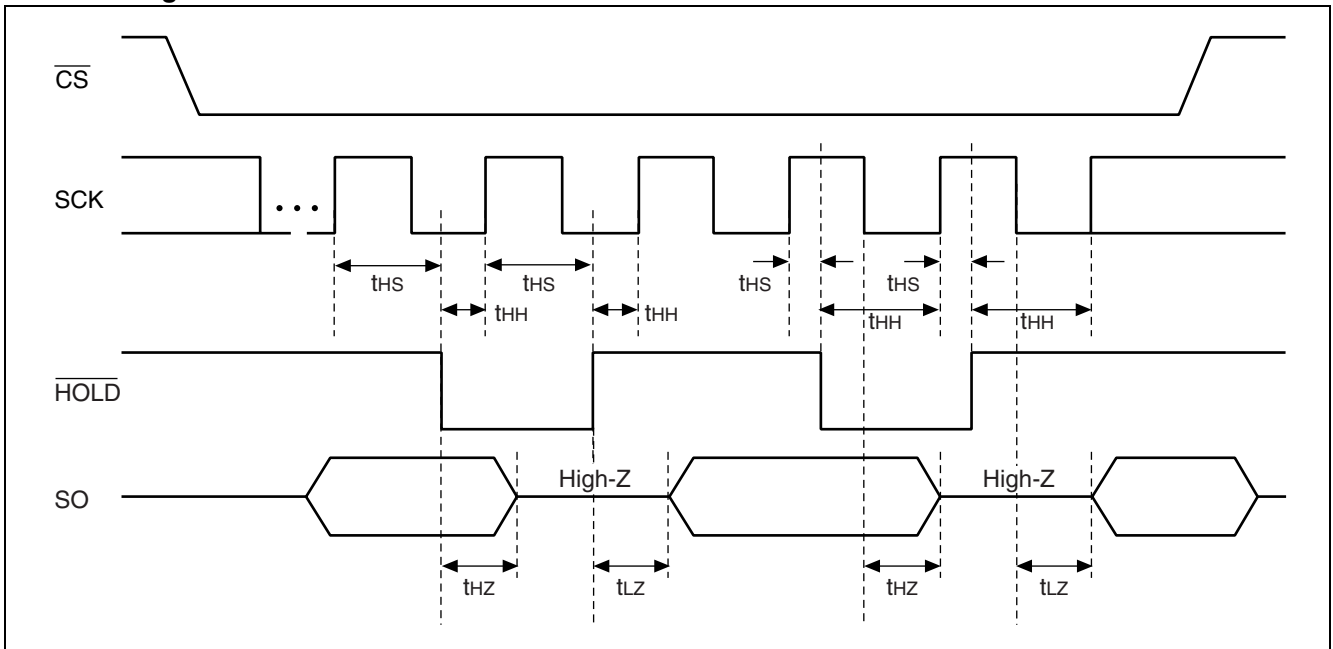

MB85RS256

POWER ON/OFF SEQUENCE

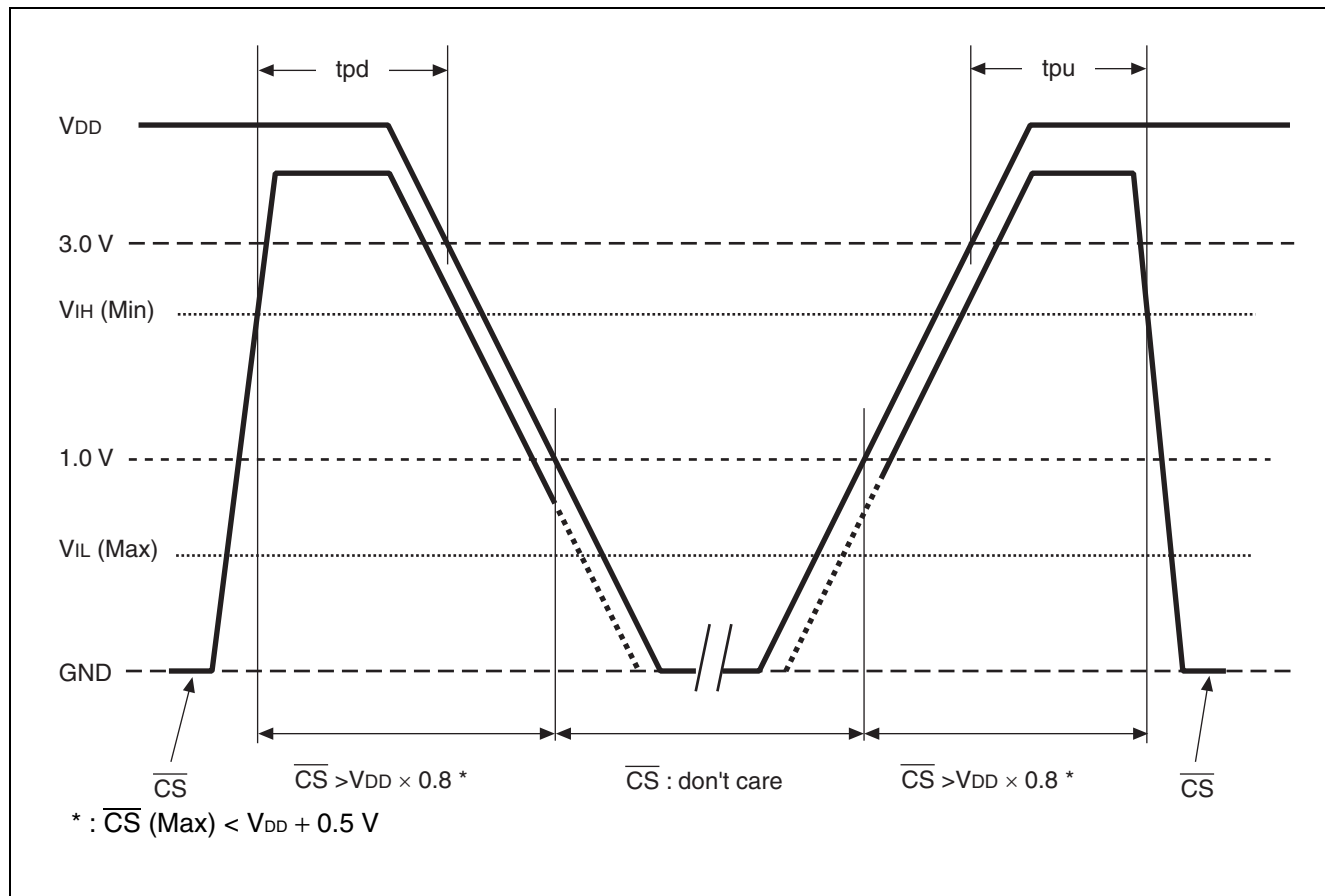

Parameter	Symbol	Value		Unit
		Min	Max	
\overline{CS} level hold time at power OFF	tpd	85	—	ns
\overline{CS} level hold time at power ON	tpu	85	—	ns

NOTES ON USE

After IR reflow, the hold of data that was written before IR reflow is not guaranteed.

■ ORDERING INFORMATION

Part number	Package
MB85RS256PNF-G-JNE1	8-pin plastic SOP (FPT-8P-M02)

MB85RS256

PACKAGE DIMENSION

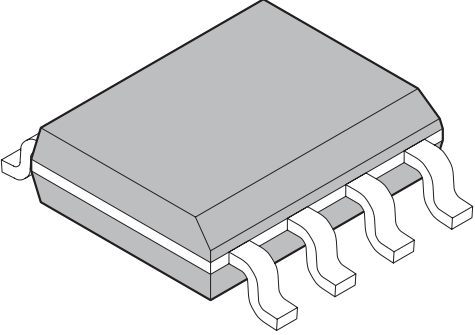
<p style="text-align: center;">8-pin plastic SOP</p>  <p style="text-align: center;">(FPT-8P-M02)</p>	Lead pitch	1.27 mm
	Package width × package length	3.9 × 5.05 mm
	Lead shape	Gullwing
	Sealing method	Plastic mold
	Mounting height	1.75 mm MAX
	Weight	0.06 g

8-pin plastic SOP
(FPT-8P-M02)

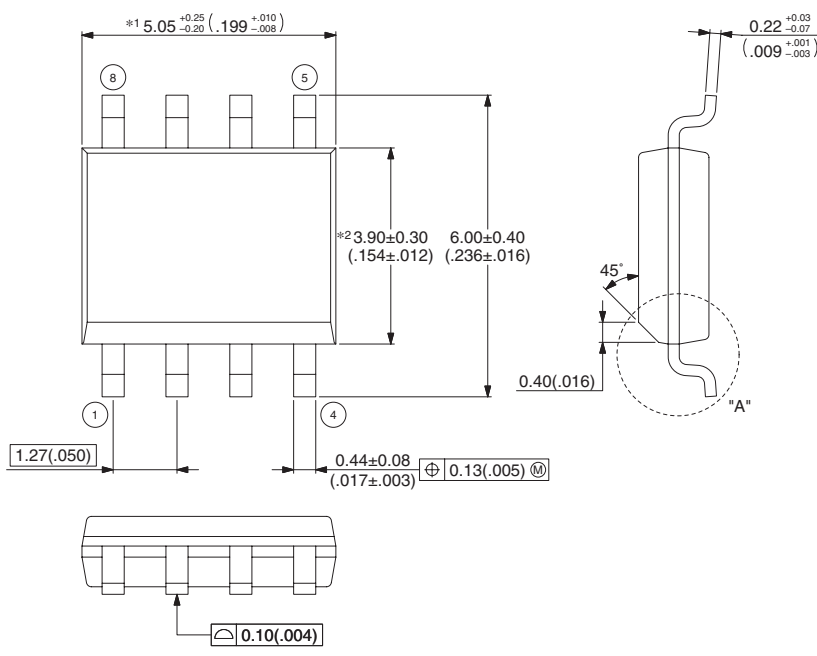

Top view dimensions:
 *1 5.05^{+0.25}/_{-0.20} (.199^{+0.10}/_{-0.08})
 *2 3.90±0.30 (.154±.012) 6.00±0.40 (.236±.016)
 1.27(.050)
 0.44±0.08 (.017±.003) 0.13(.005) ⊕
 0.10(.004)

Lead detail dimensions:
 0.22^{+0.03}/_{-0.07} (.009^{+0.001}/_{-0.003})
 45°
 0.40(.016)

Details of "A" part:
 1.55±0.20 (.061±.008) (Mounting height)
 0.25(.010)
 0-8°
 0.50±0.20 (.020±.008)
 0.60±0.15 (.024±.006)
 0.15±0.10 (.006±.004) (Stand off)

Note 1) *1 : These dimensions include resin protrusion.
 Note 2) *2 : These dimensions do not include resin protrusion.
 Note 3) Pins width and pins thickness include plating thickness.
 Note 4) Pins width do not include tie bar cutting remainder.

© 2002 FUJITSU LIMITED F08004S-c-4-7

Dimensions in mm (inches).
Note: The values in parentheses are reference values.

Please confirm the latest Package dimension by following URL.
<http://edevic.e.fujitsu.com/fj/DATASHEET/ef-ovpklv.html>

FUJITSU LIMITED

All Rights Reserved.

The contents of this document are subject to change without notice. Customers are advised to consult with FUJITSU sales representatives before ordering.

The information, such as descriptions of function and application circuit examples, in this document are presented solely for the purpose of reference to show examples of operations and uses of Fujitsu semiconductor device; Fujitsu does not warrant proper operation of the device with respect to use based on such information. When you develop equipment incorporating the device based on such information, you must assume any responsibility arising out of such use of the information. Fujitsu assumes no liability for any damages whatsoever arising out of the use of the information.

Any information in this document, including descriptions of function and schematic diagrams, shall not be construed as license of the use or exercise of any intellectual property right, such as patent right or copyright, or any other right of Fujitsu or any third party or does Fujitsu warrant non-infringement of any third-party's intellectual property right or other right by using such information. Fujitsu assumes no liability for any infringement of the intellectual property rights or other rights of third parties which would result from the use of information contained herein.

The products described in this document are designed, developed and manufactured as contemplated for general use, including without limitation, ordinary industrial use, general office use, personal use, and household use, but are not designed, developed and manufactured as contemplated (1) for use accompanying fatal risks or dangers that, unless extremely high safety is secured, could have a serious effect to the public, and could lead directly to death, personal injury, severe physical damage or other loss (i.e., nuclear reaction control in nuclear facility, aircraft flight control, air traffic control, mass transport control, medical life support system, missile launch control in weapon system), or (2) for use requiring extremely high reliability (i.e., submersible repeater and artificial satellite).

Please note that Fujitsu will not be liable against you and/or any third party for any claims or damages arising in connection with above-mentioned uses of the products.

Any semiconductor devices have an inherent chance of failure. You must protect against injury, damage or loss from such failures by incorporating safety design measures into your facility and equipment such as redundancy, fire protection, and prevention of over-current levels and other abnormal operating conditions.

If any products described in this document represent goods or technologies subject to certain restrictions on export under the Foreign Exchange and Foreign Trade Law of Japan, the prior authorization by Japanese government will be required for export of those products from Japan.

The company names and brand names herein are the trademarks or registered trademarks of their respective owners.

Edited Business Promotion Dept.