

## 7.92 mm Contact Pitch, High-Current Connectors for Internal Power Supplies (UL, C-UL and TÜV Listed)

### DF22 Series

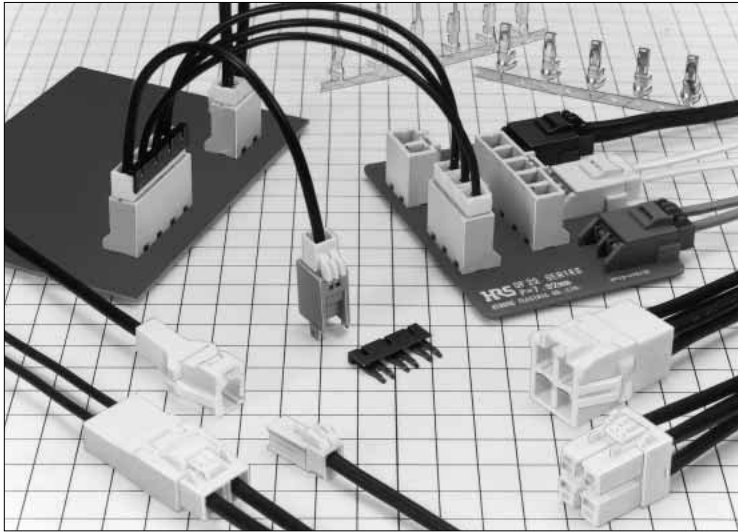

#### Complete Locking Function

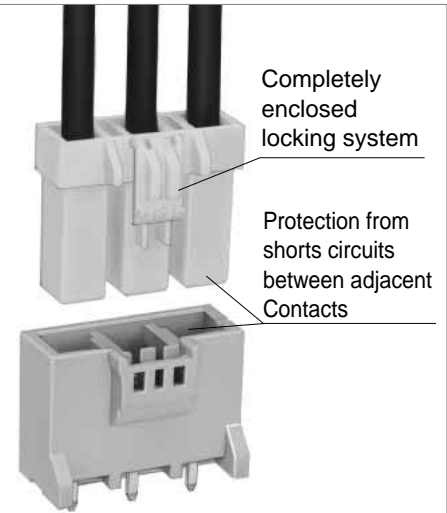

#### ■ Features

##### 1. 30 A maximum current

Single position connector can carry current of 30 A with #10 AWG conductor. Please refer to Table #1 for current ratings for multi-position connectors using other conductor sizes.

##### 2. Complete Locking Function

Reliable interior lock protects mated connectors from accidental disconnection.

##### 3. Prevention of Incorrect Connections

To prevent incorrect connection when using multiple connectors having the same Number of contacts, 3 product types having different mating configurations are available.

##### 4. Molded-in contact retention tabs

Handling of terminated contacts during the crimping is easier and avoids entangling of wires, since there are no protruding metal tabs.

##### 5. Prevention of incorrect board placement

Built-in posts assure correct connector placement and orientation on the board.

##### 6. Supports encapsulation

Connectors can be encapsulated up to 10 mm without affecting the performance.

##### 7. Prevention of Short Circuits Between Adjacent Contacts

Each Contact is completely surrounded by the insulator housing electrically isolating it from adjacent contacts.

##### 8. Increased Retention Force of Crimped Contacts and confirmation of complete contact insertion

Separate contact retainers are provided for applications where extreme pull-out forces may be applied against the wire or when a visual confirmation of the full contact insertion is required.

##### 9. Full Line of Crimp Socket Contacts

Realizing the market needs for multitude of different applications, Hirose has developed several variants of crimp socket contacts and housings. Continuous development is adding different variations. Contact your nearest Hirose Electric representative for latest developments.

##### 10. In-line Connections

Connectors can be ordered for in-line cable connections. In addition, assemblies can be placed next to each other allowing 4 position total (2 × 2) in a small space.

##### 11. Listed by UL, C-UL, and TÜV.

#### Prevention of Incorrect Connections

##### ● R Type (Guide key: right side, Color: black)

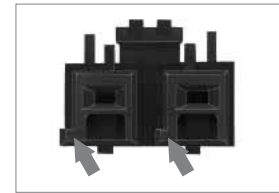

##### ● Standard Type (Guide key: inside, Color: natural)

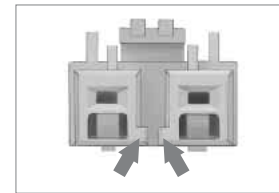

##### ● L Type (Guide key: left side, Color: red)

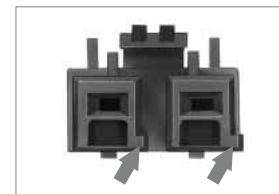

\*The photographs on the left show header (the board dip side), the photographs on the right show the socket (cable side).

\*The guide key position is indicated in position facing the mating surface of the header.

#### ■ Applications

Office equipment, power supplies for industrial, medical and instrumentation applications, variety of consumer electronic, and electrical applications.

**DF22 Series 7.92 mm Contact Pitch, High-Current Connectors for Internal Power Supplies (UL, C-UL and TÜV Listed)**

**Product Specifications**

Ratings	Current rating	Number of contacts	AWG10	AWG12	AWG14	AWG16	Operating temperature range	-35°C to 85°C (Note 1)	
		1	30A	25A	20A	15A	Operating humidity range	20% to 80%	
		2	25A	20A	18A	15A	Storage temperature range	-10°C to 60°C (Note 2)	
		3	25A	20A	18A	15A			
		4	22A	18A	15A	13A			
	5	22A	18A	15A	13A	Storage humidity range	40% to 70% (Note 2)		
	Voltage rating	Specification		AC/DC		1000V	UL/C-UL/TÜV	File No. and Recognition No.	
		UL/C-UL		AC/DC		600V		UL	: E52653
		TÜV		AC/DC		600V		C-UL	: E52653
							TÜV	: R9950703	

Item	Specification	Condition
1. Contact resistance	Contact resistance(Initial value): 5 m ohms max.	20mV max., 1mA
2. Insulator resistance	1000 M ohms min.	1000 V DC
3. Withstanding voltage	No flashover or Insulator breakdown	2500 V AC for 1 minute
4. Insertion-Extraction force (per contact)	0.3N min., 5N max.	Measured with a steel pin of 1.6 x 0.8 ± 0.002 thickness
5. Durability (mating/unmating)	Contact resistance of 10 m ohms max.	30 cycles
6. Vibration	No electrical discontinuity of 1 μs. min.	Frequency 10 to 55 Hz, single amplitude of 0.75 mm, 3 axis, duration of 2 hours
7. Shock	No electrical discontinuity of 1 μs. min.	Acceleration of 490 m/s <sup>2</sup> , 11 ms duration, sine half-wave waveform, 3 cycles in each of the 3 axis.
8. Humidity	Contact resistance 10 m ohms max.	Temperature 40°C ± 2°C, 90% to 95% RH, 96 hours
9. Temperature cycle	Contact resistance of 10 m ohms max.	(-55°C: 30 minutes→5 to 35°C: 5 minutes→85°C: 30 minutes→5 to 35°C: 5 minutes) for 5 cycles
10. Resistance to Soldering heat	No deformation of the insulator parts affecting performance	Flow solder temperature 250°C, for 10 seconds Manual soldering: Soldering iron temperature 300°C, 3 seconds

Note 1: Current rating of header is 30A (1 pos.) and 25A (2 to 5 pos.)

Note 2: Includes temperature rise caused by the current flow.

Note 3: The term "storage" refers to products stored for long period of time prior to mounting and use. Operating Temperature Range and Humidity range covers non- conducting condition of installed connectors in storage, shipment or during transportation.

Note 4: Information contained in this catalog represents general requirements for this Series. Contact us for the drawings and specifications for a specific part number shown.

**Materials**

Product	Part	Material	Finish	Remarks
Sockets	Insulator	Polyamide	Color: Natural white (Note)	UL94V-0
Crimp contacts	Contacts	High conductivity copper alloy	Tin-lead plated	—
Headers	Insulator	Polyamide (Glass reinforced)	Color: Natural beige (Note)	UL94V-0
	Contacts	High conductivity copper alloy	Tin-copper plated	—

Note : Standard Color, colors of the differing coupling forms are black for DF22R and red for DF22L.

**Ordering Information**

**Socket, Header**

**DF22 B L - 2 S - 7.92 C**

① ② ③ ④ ⑤ ⑥ ⑦

**Contacts**

**DF22 A - 1416 SCF**

① ⑧ ⑨ ⑩

① Series name: DF22	④ Number of contacts : 1 to 5	⑧ Applicable Cable Blank : UL1430 A : UL1015
② Form Type Sockets Blank : Standard height, standard lock (Type I) B : Long type, standard lock (Type III) C : Long type, ergonomic lock (Type IV) In-line Plugs Blank : With panel stop A : Without panel stop	⑤ Connector type S : Socket DS : Double-row socket P : Header EP : In-line plug DEP : Double-row in-line plug RS/P : Retainer	
③ Guide key type Blank : Inside (Color: natural) R : Right side (Color: black) L : Left side (Color: red)	⑥ Contact pitch : 7.92 mm	⑩ Packaging SCF : Socket contacts / Reel SC : Socket contacts / Bag PCF : In-line plug contacts / Reel PC : In-line plug contacts / Bag
	⑦ Type of housing C : Crimp housing DSA : Straight header DS : Right-angle header No letter : Retainer	

**DF22 Series 7.92 mm Contact Pitch, High-Current Connectors for Internal Power Supplies (UL, C-UL and FCC Listed)**

**■ Crimp Sockets (Standard Type)**

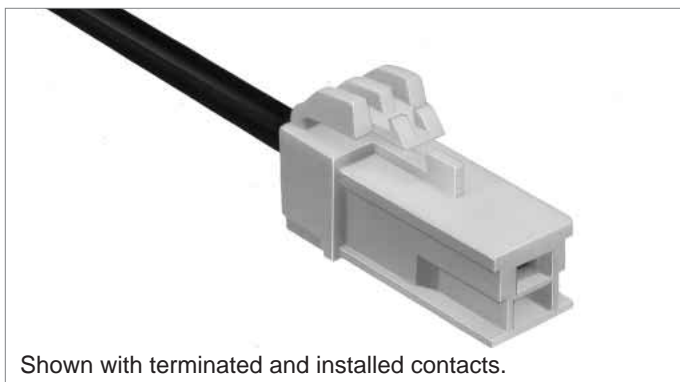

Shown with terminated and installed contacts.

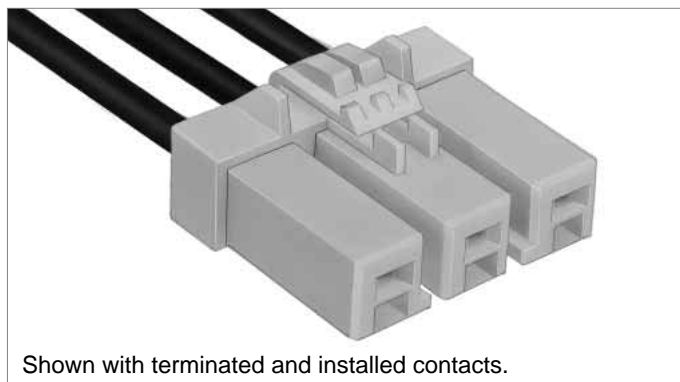

Shown with terminated and installed contacts.

**1 Pos.**

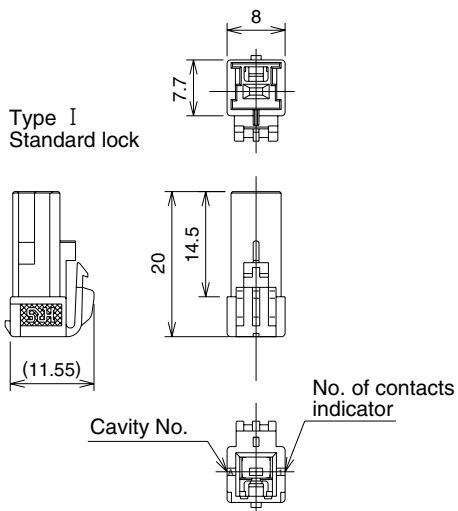

**2 to 5 Pos.**

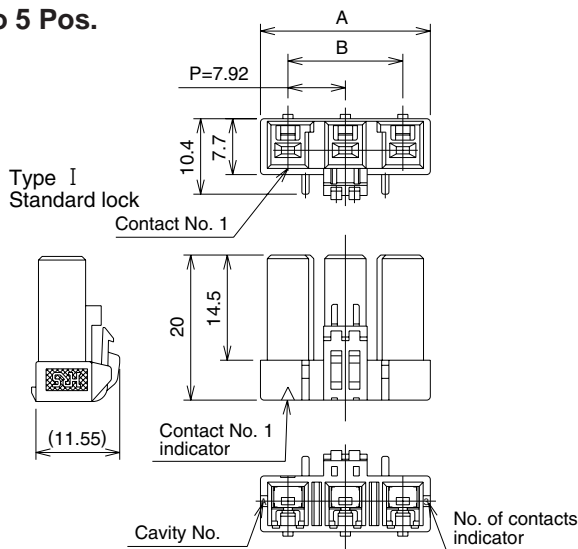

**■ Type I**

**Height: Standard type, Standard lock**

Note: The part number and CL No. have changed to accommodate the product form change of the 2 to 5 pos. types.

**Standard Type (Guide Key: Inside, Color: White)**

Part Number	CL No.	Number of contacts	A	B	RoHS
DF22-1S-7.92C(28)	680-1012-2-28	1	8.00	—	YES
DF22-2S-7.92C(28)	680-1004-4-28	2	15.50	7.92	
DF22-3S-7.92C(28)	680-1005-7-28	3	23.42	15.84	
DF22-4S-7.92C(28)	680-1006-0-28	4	31.34	23.76	
DF22-5S-7.92C(28)	680-1007-2-28	5	39.26	31.68	

**R Type (Guide Key: Right Side, Color: Black)**

Part Number	CL No.	Number of contacts	A	B	RoHS
DF22R-1S-7.92C(28)	680-1026-7-28	1	8.00	—	YES
DF22R-2S-7.92C(28)	680-1027-0-28	2	15.50	7.92	
DF22R-3S-7.92C(28)	680-1028-2-28	3	23.42	15.84	
DF22R-4S-7.92C(28)	680-1029-5-28	4	31.34	23.76	
DF22R-5S-7.92C(28)	680-1030-4-28	5	39.26	31.68	

**L Type (Guide Key: Left Side, Color: Red)**

Part Number	CL No.	Number of contacts	A	B	RoHS
DF22L-1S-7.92C(28)	680-1031-7-28	1	8.00	—	YES
DF22L-2S-7.92C(28)	680-1032-0-28	2	15.50	7.92	
DF22L-3S-7.92C(28)	680-1033-2-28	3	23.42	15.84	
DF22L-4S-7.92C(28)	680-1034-5-28	4	31.34	23.76	
DF22L-5S-7.92C(28)	680-1035-8-28	5	39.26	31.68	

Note: Bag packaging (100 pieces/bag). Order by number of bags.

**DF22 Series 7.92 mm Contact Pitch, High Current Connectors for Internal Power Supplies (UL, C-UL and TUV Listed)**

**■ Crimp Sockets (Height, Long Type)**

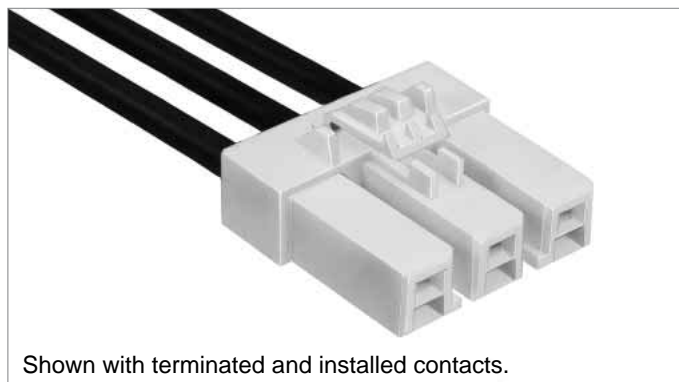
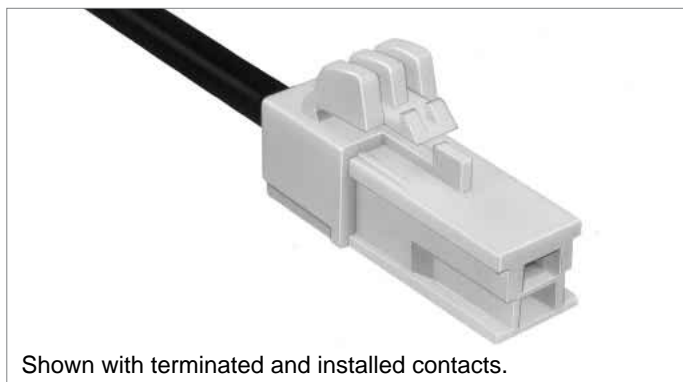

**1 Pos.**

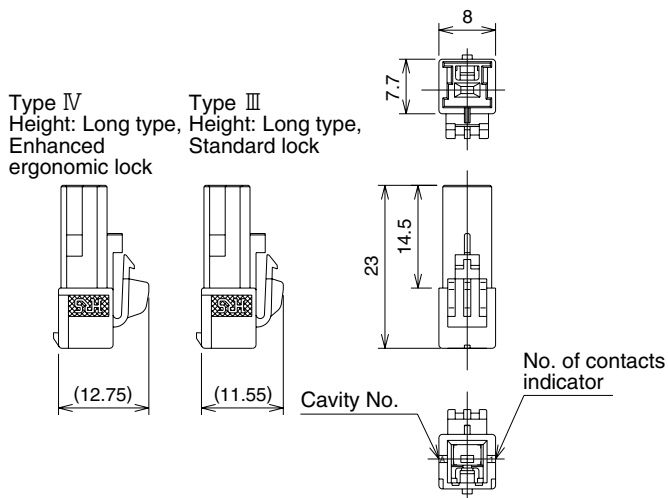

**2 to 5 Pos.**

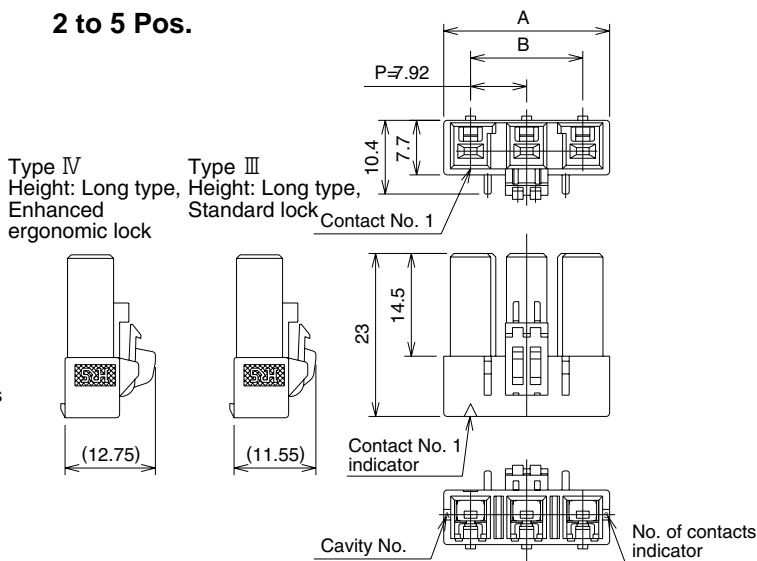

**■ Type III**

Height: Long type, Standard lock

**Standard Type (Guide Key: Inside, Color: White)**

Part Number	CL No.	Number of contacts	A	B	RoHS
DF22B-2S-7.92C	680-1097-5	2	15.50	7.92	YES
DF22B-3S-7.92C	680-1098-8	3	23.42	15.84	
DF22B-4S-7.92C	680-1099-0	4	31.34	23.76	
DF22B-5S-7.92C	680-1100-8	5	39.26	31.68	

Note: Bag packaging (100 pieces/bag). Order by number of bags.

**■ Type IV**

Height: Long type, Enhanced ergonomic lock

**Standard Type (Guide Key: Inside, Color: White)**

Part Number	CL No.	Number of contacts	A	B	RoHS
DF22C-1S-7.92C	680-1101-0	1	8.00	—	YES
DF22C-2S-7.92C	680-1102-3	2	15.50	7.92	
DF22C-3S-7.92C	680-1103-6	3	23.42	15.84	
DF22C-4S-7.92C	680-1104-9	4	31.34	23.76	

**R Type (Guide Key: Right Side, Color: Black)**

Part Number	CL No.	Number of contacts	A	B	RoHS
DF22CR-3S-7.92C	680-1130-9	3	23.42	15.84	YES

**L Type (Guide Key: Left Side, Color: Red)**

Part Number	CL No.	Number of contacts	A	B	RoHS
DF22CL-1S-7.92C	680-1133-7	1	8.00	—	YES
DF22CL-3S-7.92C	680-1135-2	3	23.42	15.84	

Note: Bag packaging (100 pieces/bag). Order by number of bags.

**DF22 Series 7.92 mm Contact Pitch, High-Current Connectors for Internal Power Supplies (UL, C-UL and FCC Listed)**

**■ Straight header**

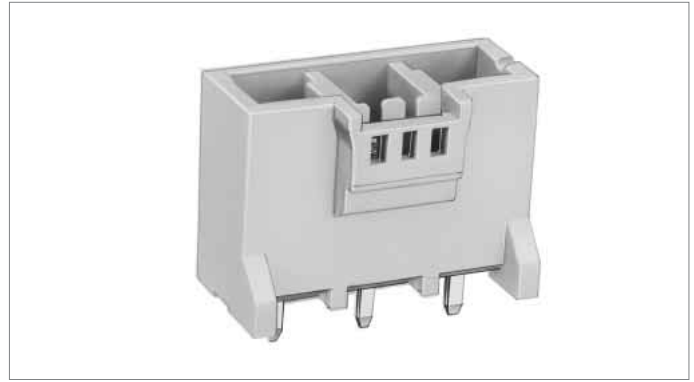
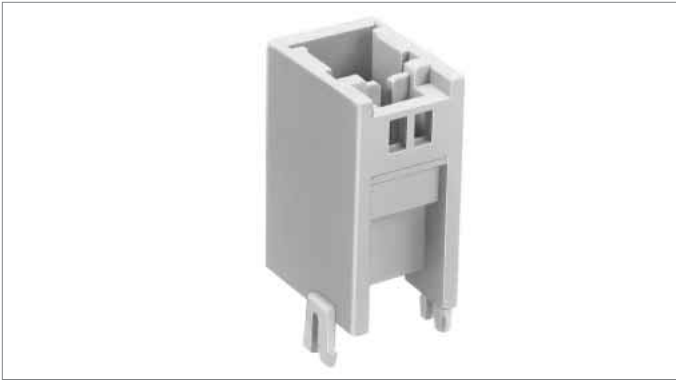

**1 Pos.**

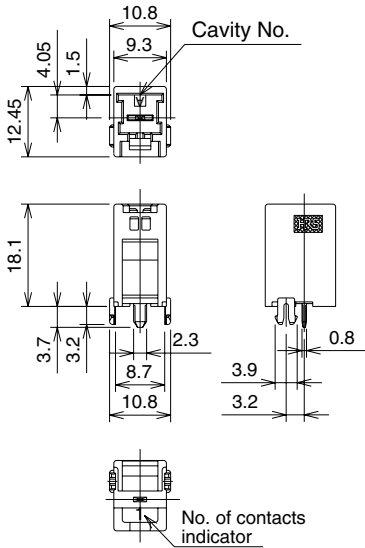

**2 to 5 Pos.**

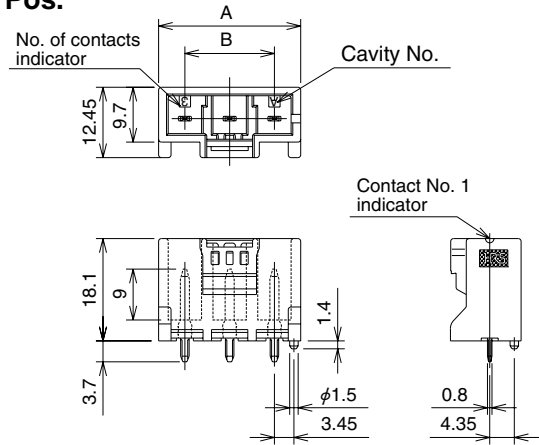

[Specification number]  
 (05) : Tin-copperplated bag packaging  
 (25) : Tin-copperplated tray packaging

**Standard Type (Guide Key: Inside, Color: Natural Beige)**

Part Number	CL No.	Number of contacts	A	B	Bag Packaging	Tray Packaging	RoHS
DF22-1P-7.92DSA(**)	680-1013-5-**-	1	10.08	—	—	✓	YES
DF22-2P-7.92DSA(**)	680-1014-8-**-	2	17.22	7.92	✓	—	
DF22-3P-7.92DSA(**)	680-1015-0-**-	3	25.14	15.84	✓	—	
DF22-4P-7.92DSA(**)	680-1016-3-**-	4	33.06	23.76	✓	—	
DF22-5P-7.92DSA(**)	680-1017-6-**-	5	40.98	31.68	✓	—	

**R Type (Guide Key: Right Side, Color: Black)**

Part Number	CL No.	Number of contacts	A	B	Bag Packaging	Tray Packaging	RoHS
DF22R-1P-7.92DSA(**)	680-1036-0-**-	1	10.08	—	—	✓	YES
DF22R-2P-7.92DSA(**)	680-1037-3-**-	2	17.22	7.92	✓	—	
DF22R-3P-7.92DSA(**)	680-1038-6-**-	3	25.14	15.84	✓	—	
DF22R-4P-7.92DSA(**)	680-1039-9-**-	4	33.06	23.76	✓	—	
DF22R-5P-7.92DSA(**)	680-1040-8-**-	5	40.98	31.68	✓	—	

**L Type (Guide Key: Left Side, Color: Red)**

Part Number	CL No.	Number of contacts	A	B	Bag Packaging	Tray Packaging	RoHS
DF22L-1P-7.92DSA(**)	680-1041-0-**-	1	10.08	—	—	✓	YES
DF22L-2P-7.92DSA(**)	680-1042-3-**-	2	17.22	7.92	✓	—	
DF22L-3P-7.92DSA(**)	680-1043-6-**-	3	25.14	15.84	✓	—	
DF22L-4P-7.92DSA(**)	680-1044-9-**-	4	33.06	23.76	✓	—	
DF22L-5P-7.92DSA(**)	680-1045-1-**-	5	40.98	31.68	✓	—	

Note 1: Bag packaging (100 pieces/bag). Order by number of bags.  
 Note 2: Tray packaging (150 pieces/tray). Order by number of 150.

**◆ PCB mounting pattern (Board thickness: 1.6±0.1)**

**1 Pos.**

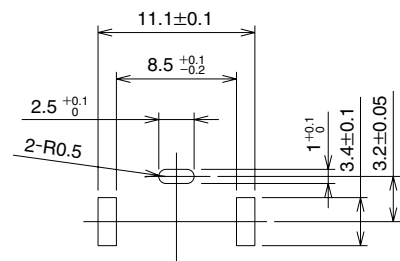

**2 to 5 Pos.**

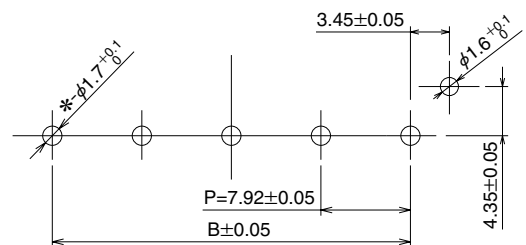

**DF22 Series 7.92 mm Contact Pitch, High-Current Connectors for Internal Power Supplies (UL, C-UL and TUV Listed)**

**Right angle header**

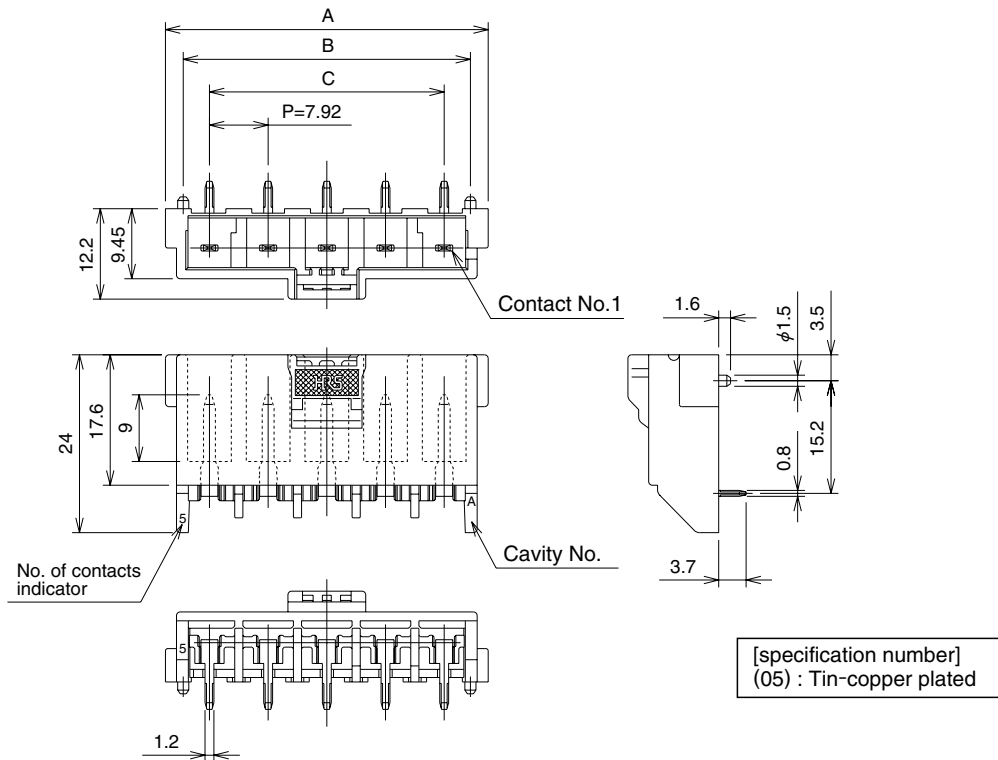
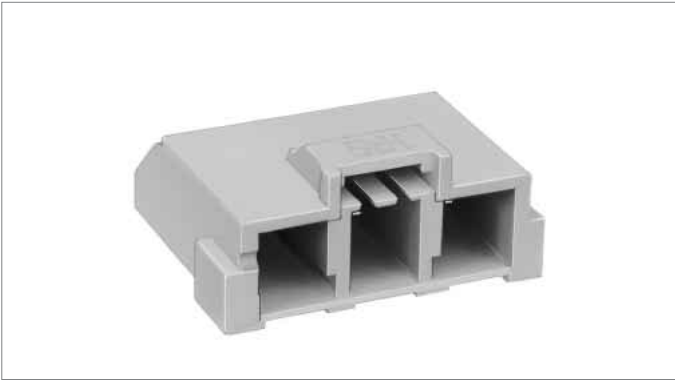

**Standard Type (Guide Key: Inside, Color: Natural Beige)**

Part Number	CL No.	Number of contacts	A	B	C	RoHS
DF22-2P-7.92DS(05)	680-1008-5-05	2	19.80	15.00	7.92	YES
DF22-3P-7.92DS(05)	680-1009-8-05	3	27.72	22.92	15.84	
DF22-4P-7.92DS(05)	680-1010-7-05	4	35.64	30.84	23.76	
DF22-5P-7.92DS(05)	680-1011-0-05	5	43.56	38.76	31.68	

**R Type (Guide Key: Right Side, Color: Black)**

Part Number	CL No.	Number of contacts	A	B	C	RoHS
DF22R-2P-7.92DS(05)	680-1018-9-05	2	19.80	15.00	7.92	YES
DF22R-3P-7.92DS(05)	680-1019-1-05	3	27.72	22.92	15.84	
DF22R-4P-7.92DS(05)	680-1020-0-05	4	35.64	30.84	23.76	
DF22R-5P-7.92DS(05)	680-1021-3-05	5	43.56	38.76	31.68	

**L Type (Guide Key: Left Side, Color: Red)**

Part Number	CL No.	Number of contacts	A	B	C	RoHS
DF22L-2P-7.92DS(05)	680-1022-6-05	2	19.80	15.00	7.92	YES
DF22L-3P-7.92DS(05)	680-1023-9-05	3	27.72	22.92	15.84	
DF22L-4P-7.92DS(05)	680-1024-1-05	4	35.64	30.84	23.76	
DF22L-5P-7.92DS(05)	680-1025-4-05	5	43.56	38.76	31.68	

Note: Bag packaging (100 pieces/bag). Order by number of bags.

**PCB mounting pattern (Board thickness: 1.6±0.1)**

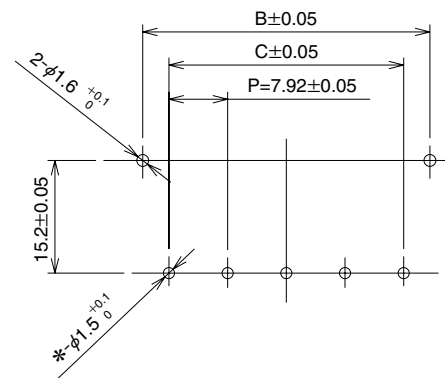



**DF22 Series 7.92 mm Contact Pitch, High-Current Connectors for Internal Power Supplies (UL, C-UL and FCC Listed)**

**■ In-line plug (Panel lock type)**

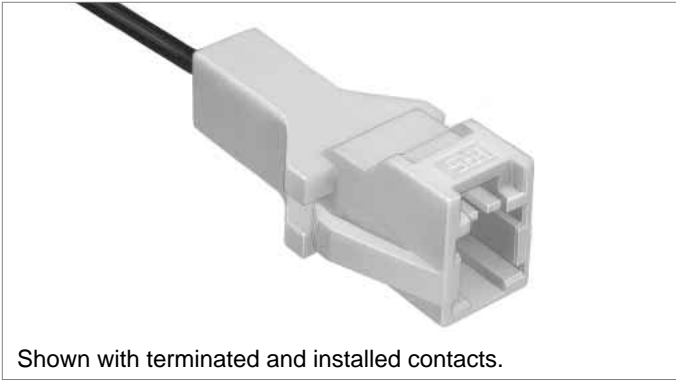

**1 Pos.**

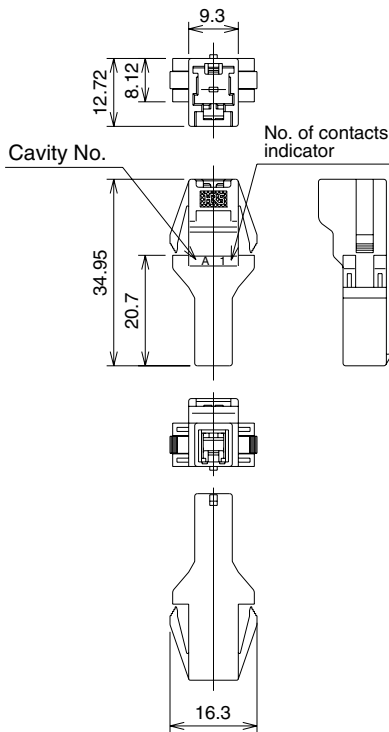

**2, 3 Pos.**

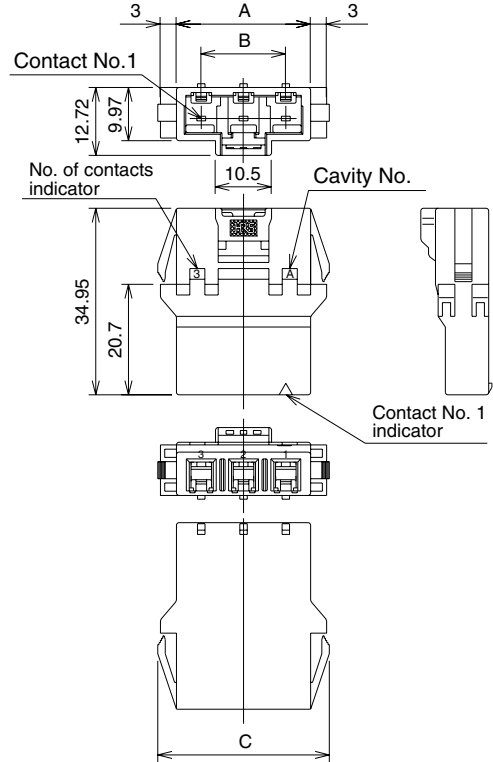

**Standard Type (Guide Key: Inside, Color: White)**

Part Number	CL No.	Number of contacts	A	B	C	RoHS
DF22-1EP-7.92C	680-1048-0	1	9.30	—	16.30	
DF22-2EP-7.92C	680-1049-2	2	17.22	7.92	24.22	YES
DF22-3EP-7.92C	680-1050-1	3	25.14	15.84	32.14	

**R Type (Guide Key: Right Side, Color: Black)**

Part Number	CL No.	Number of contacts	A	B	C	RoHS
DF22R-2EP-7.92C	680-1059-6	2	17.22	7.92	24.22	YES
DF22R-3EP-7.92C	680-1060-5	3	25.14	15.84	32.14	

**L Type (Guide Key: Left Side, Color: Red)**

Part Number	CL No.	Number of contacts	A	B	C	RoHS
DF22L-1EP-7.92C	680-1063-3	1	9.30	—	16.30	YES
DF22L-2EP-7.92C	680-1064-6	2	17.22	7.92	24.22	

Note: Bag packaging (100 pieces/bag). Order by number of bags.

**◆ Panel Cutout**

**1 Pos.**

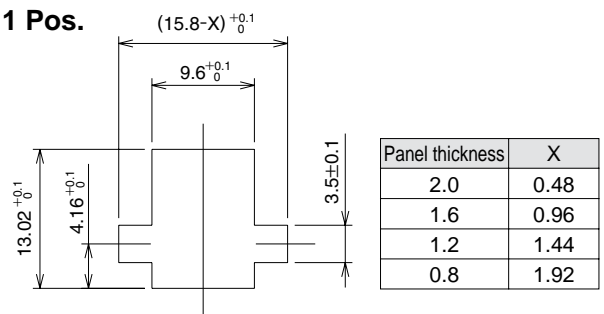

**2, 3 Pos.**

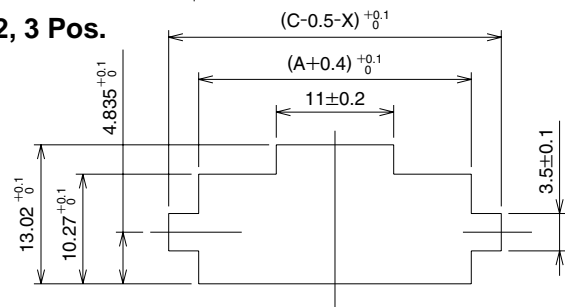

**DF22 Series 7.92 mm Contact Pitch, High-Current Connectors for Internal Power Supplies (UL, C-UL and TUV Listed)**

**In-line Plug**

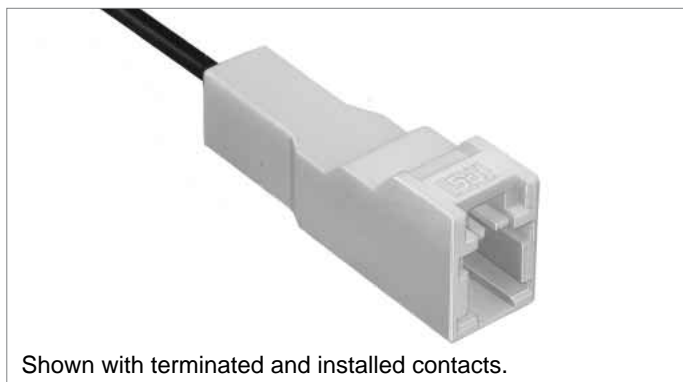

Shown with terminated and installed contacts.

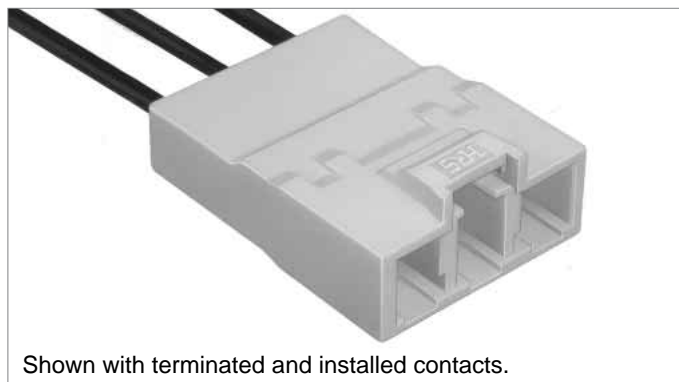

Shown with terminated and installed contacts.

**1 Pos.**

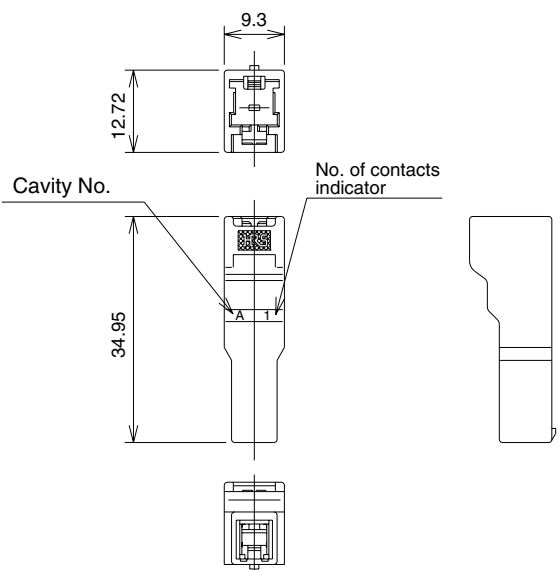

**2, 3 Pos.**

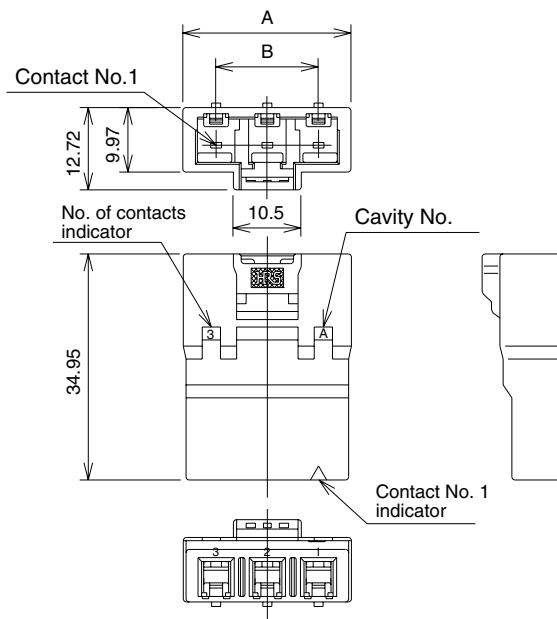

**Standard Type (Guide Key: Inside, Color: Natural Beige)**

Part Number	CL No.	Number of contacts	A	B	RoHS
DF22A-1EP-7.92C	680-1053-0	1	9.30	—	
DF22A-2EP-7.92C	680-1054-2	2	18.00	7.92	YES
DF22A-3EP-7.92C	680-1055-5	3	26.00	15.84	

**R Type (Guide Key: Right Side, Color: Black)**

Part Number	CL No.	Number of contacts	A	B	RoHS
DF22AR-2EP-7.92C	680-1069-0	2	18.00	7.92	
DF22AR-3EP-7.92C	680-1070-9	3	26.00	15.84	YES

**L Type (Guide Key: Left Side, Color: Red)**

Part Number	CL No.	Number of contacts	A	B	RoHS
DF22AL-2EP-7.92C	680-1074-0	2	18.00	7.92	YES

Note: Bag packaging (100 pieces/bag). Order by number of bags.



**DF22 Series 7.92 mm Contact Pitch, High-Current Connectors for Internal Power Supplies (UL, C-UL and FCC Listed)**

**In-line Double-row socket**

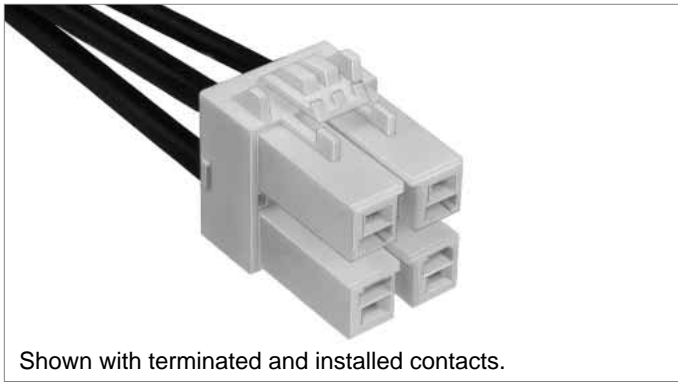

Shown with terminated and installed contacts.

**Standard Type (Guide Key: Inside, Color: White)**

Part Number	CL No.	Number of contacts	Lock type	RoHS
DF22B-4DS-7.92C	680-1142-8	4	Standard lock	YES

**R Type (Guide Key: Right Side, Color: Black)**

Part Number	CL No.	Number of contacts	Lock type	RoHS
DF22BR-4DS-7.92C	680-1156-2	4	Standard lock	YES

**L Type (Guide Key: Left Side, Color: Red)**

Part Number	CL No.	Number of contacts	Lock type	RoHS
DF22BL-4DS-7.92C	680-1161-2	4	Standard lock	YES

Note: Bag packaging (100 pieces/bag). Order by number of bags.

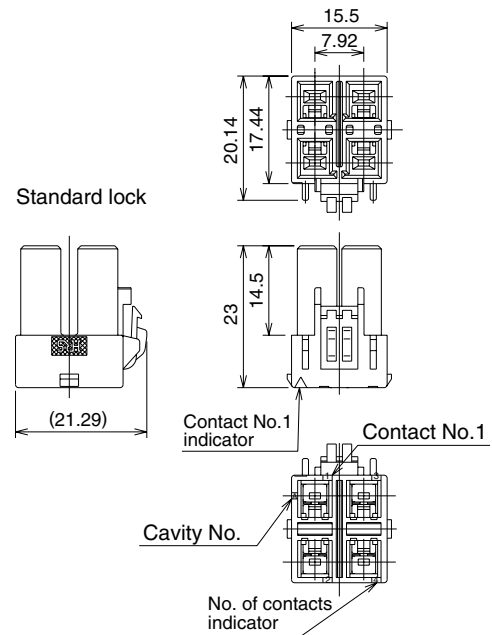

**In-line Double-row Plug**

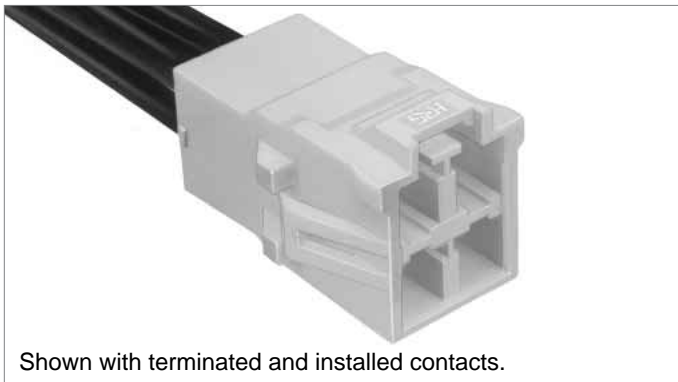

Shown with terminated and installed contacts.

**Standard Type (Guide Key: Inside, Color: White)**

Part Number	CL No.	Number of contacts	Connector type	RoHS
DF22-4DEP-7.92C	680-1051-4	4	With snap-in tabs	YES
DF22A-4DEP-7.92C	680-1056-8	4	Without snap-in tabs	

**R Type (Guide Key: Right Side, Color: Black)**

Part Number	CL No.	Number of contacts	Connector type	RoHS
DF22R-4DEP-7.92C	680-1170-3	4	With snap-in tabs	YES
DF22AR-4DEP-7.92C	680-1184-8	4	Without snap-in tabs	

**L Type (Guide Key: Left Side, Color: Red)**

Part Number	CL No.	Number of contacts	Connector type	RoHS
DF22L-4DEP-7.92C	680-1175-7	4	With snap-in tabs	YES
DF22AL-4DEP-7.92C	680-1189-1	4	Without snap-in tabs	

Note: Bag packaging (100 pieces/bag). Order by number of bags.

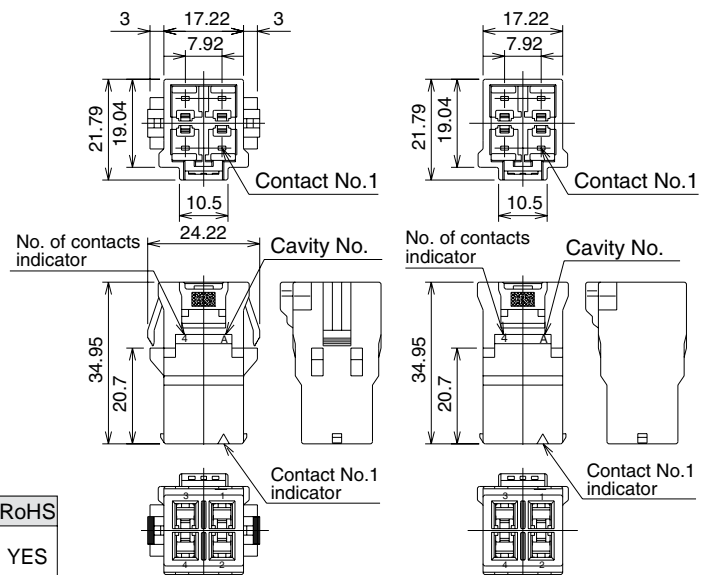

**Panel Cutout (Panel mount type)**

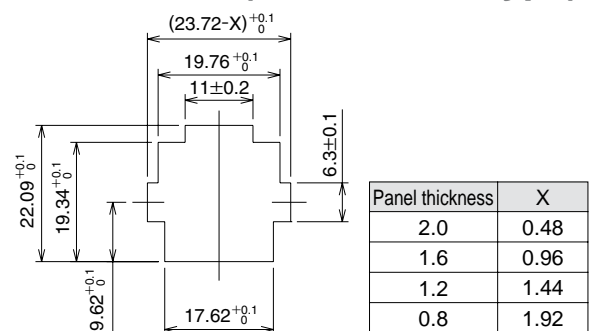

**DF22 Series 7.92 mm Contact Pitch, High-Current Connectors for Internal Power Supplies (UL, C-UL and TUV Listed)**

**Retainer**

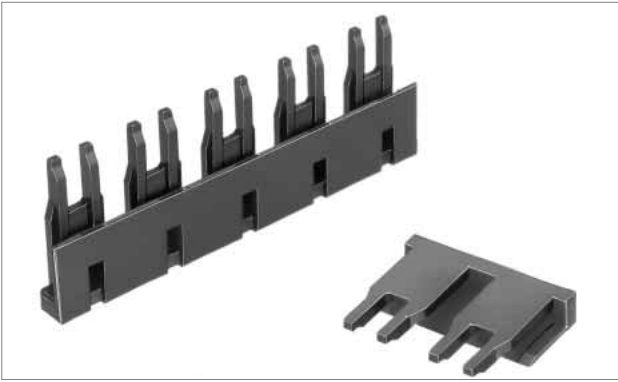

**For Standard height, standard lock (Type I)**

**For Long type, standard lock (Type III)  
 Long type, enhanced ergonomic lock (Type IV)**

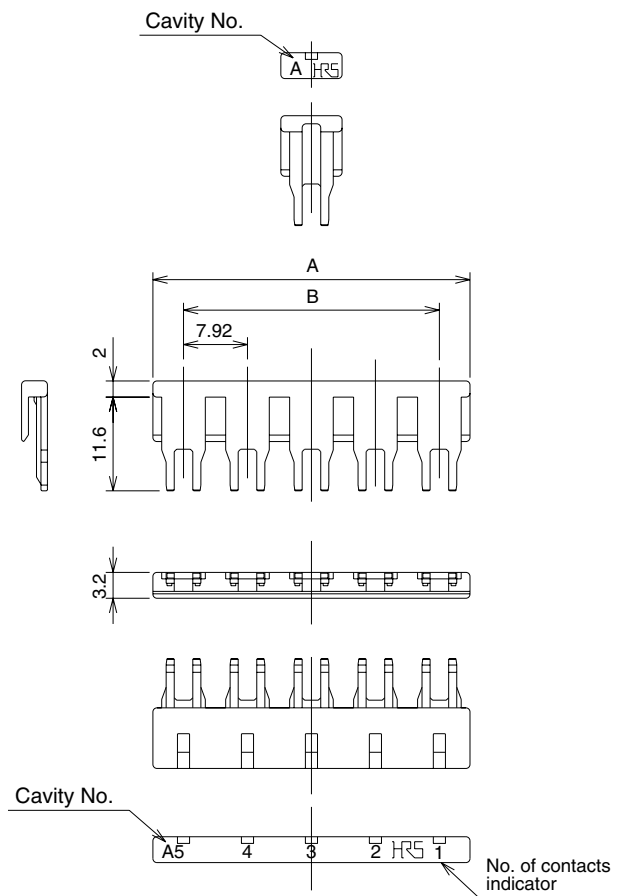
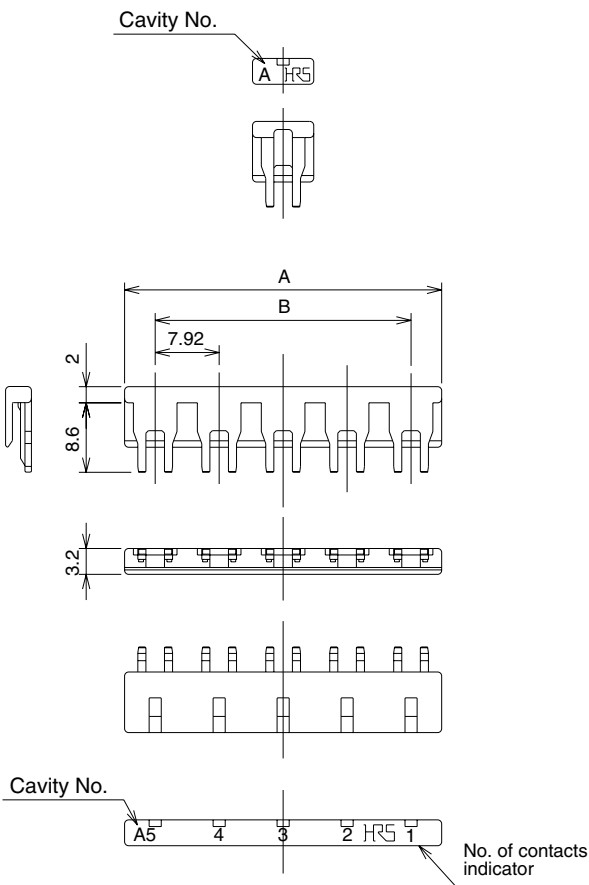

Part Number	CL No.	Number of contacts	A	B	RoHS
DF22-2RS/P-7.92	680-1209-7	2	15.50	7.92	YES
DF22-3RS/P-7.92	680-1210-6	3	23.42	15.84	
DF22-4RS/P-7.92	680-1211-9	4	31.34	23.76	
DF22-5RS/P-7.92	680-1212-1	5	39.26	31.68	
Applicable Socket	DF22-*S-7.92C For Standard height, standard lock (Type I) * indicates number of contacts.				

Note: Bag packaging (100 pieces/bag). Order by number of bags.

Part Number	CL No.	Number of contacts	A	B	RoHS
DF22B/C-2RS/P-7.92	680-1200-2	2	15.50	7.92	YES
DF22B/C-3RS/P-7.92	680-1201-5	3	23.42	15.84	
DF22B/C-4RS/P-7.92	680-1202-8	4	31.34	23.76	
DF22B/C-5RS/P-7.92	680-1203-0	5	39.26	31.68	
Applicable Socket	DF22B-*S-7.92C For Long type, standard lock (Type III) DF22C-*S-7.92C Long type, enhanced ergonomic lock (Type IV) DF22-*EP-7.92C DF22A-*EP-7.92C * indicates number of contacts.				

Note: Bag packaging (100 pieces/bag). Order by number of bags.

**DF22 Series 7.92 mm Contact Pitch, High-Current Connectors for Internal Power Supplies (UL, C-UL and FCC Listed)**

**■Crimp Contact for socket**

**For AWG# 14 to 16**

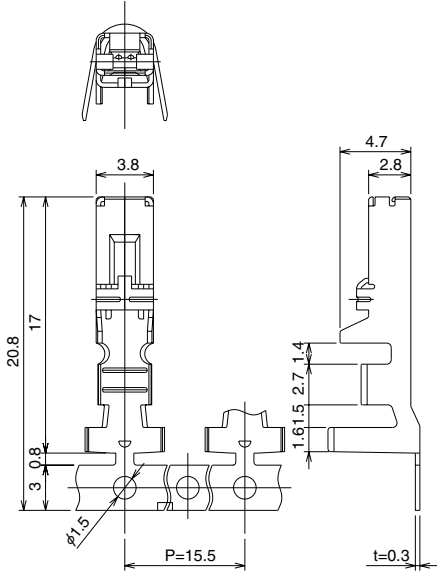

**For AWG# 10 to 12**

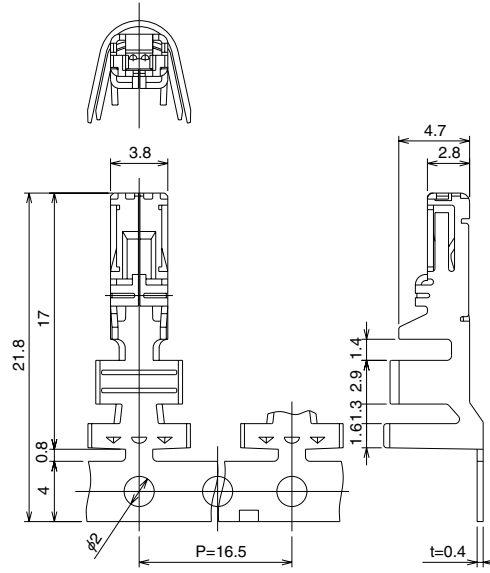

Part Number	CL No.	Applicable cable				Packaging	Quantity	RoHS
		UL style	Jacket diameter	Wire size	Stranded wire conductor			
DF22-1416SCF	680-1000-3	1430	2.4 to 3.0	AWG#16	26/0.254	Reel	2,500	YES
DF22-1416SC	680-1001-6			AWG#14	41/0.26	Bag	100	
DF22A-1416SCF	680-1002-9	1015	3.0 to 3.8	AWG#12	65/0.26	Reel	2,000	
DF22A-1416SC	680-1003-1					Bag	100	
DF22A-1012SCF	680-1089-7	1015	3.6 to 4.9	AWG#10	104/0.26	Reel	2,000	
DF22A-1012SC	680-1090-6					Bag	100	

Note 1: Applicable wire with tin plated solid soft conductor.

Note 2: When using other than the recommended wire, contact your nearest Hirose representative.

Note 3: Strip length: 3.5 to 4.5mm

**■Crimp Contact for In-line Plug**

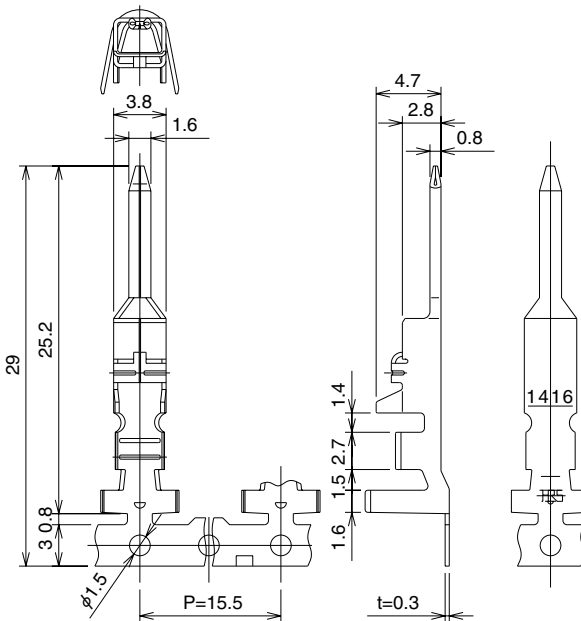

Part Number	CL No.	Applicable cable				Packaging	Quantity	RoHS
		UL style	Jacket diameter	Wire size	Stranded wire conductor			
DF22-1416PCF	680-1078-0	1430	2.4 to 3.0	AWG#16	26/0.254	Reel	2,500	YES
DF22-1416PC	680-1080-2			AWG#14	41/0.26	Bag	100	
DF22A-1416PCF	680-1079-3	1015	3.0 to 3.8	AWG#12	65/0.26	Reel	2,000	
DF22A-1416PC	680-1081-5					Bag	100	

Note 1: Applicable wire with tin plated solid soft conductor.

Note 2: When using other than the recommended wire, contact your nearest Hirose representative.

Note 3: Strip length: 3.5 to 4.5mm

**DF22 Series 7.92 mm Contact Pitch, High-Current Connectors for Internal Power Supplies (UL, C-UL and TUV Listed)**

**◆ Mating Dimensions**

**● Socket to Straight Header Connection**

**1 Pos.**

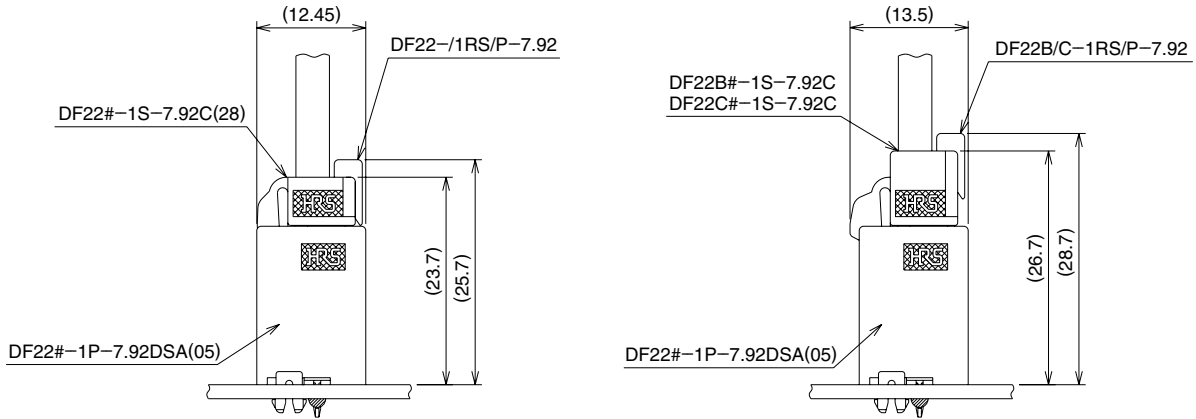

**2 to 5 Pos.**

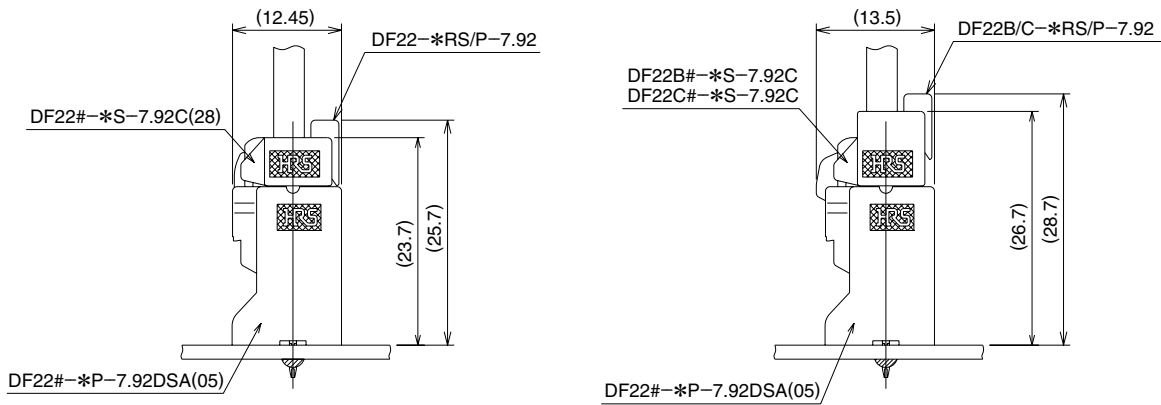

**● Socket to Right angle Header Connection**

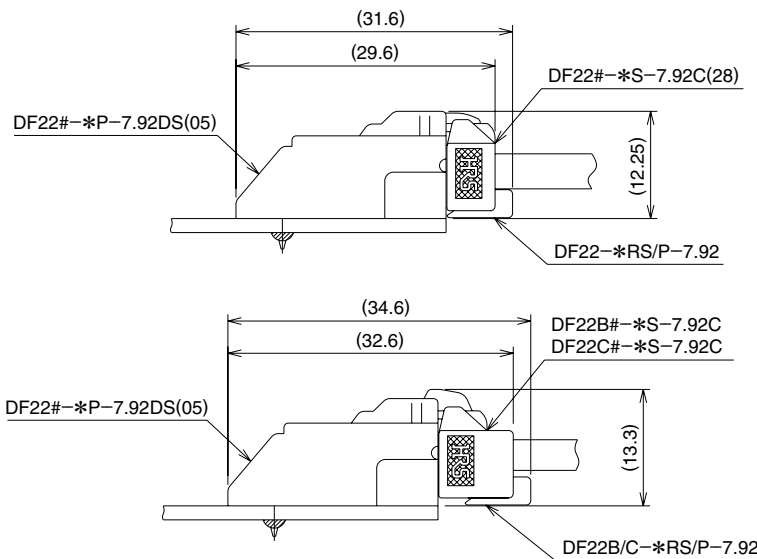

**DF22 Series 7.92 mm Contact Pitch, High-Current Connectors for Internal Power Supplies (UL, C-UL and FCC Listed)**

**●Socket to In-line Plug (Panel mount type) Connection**

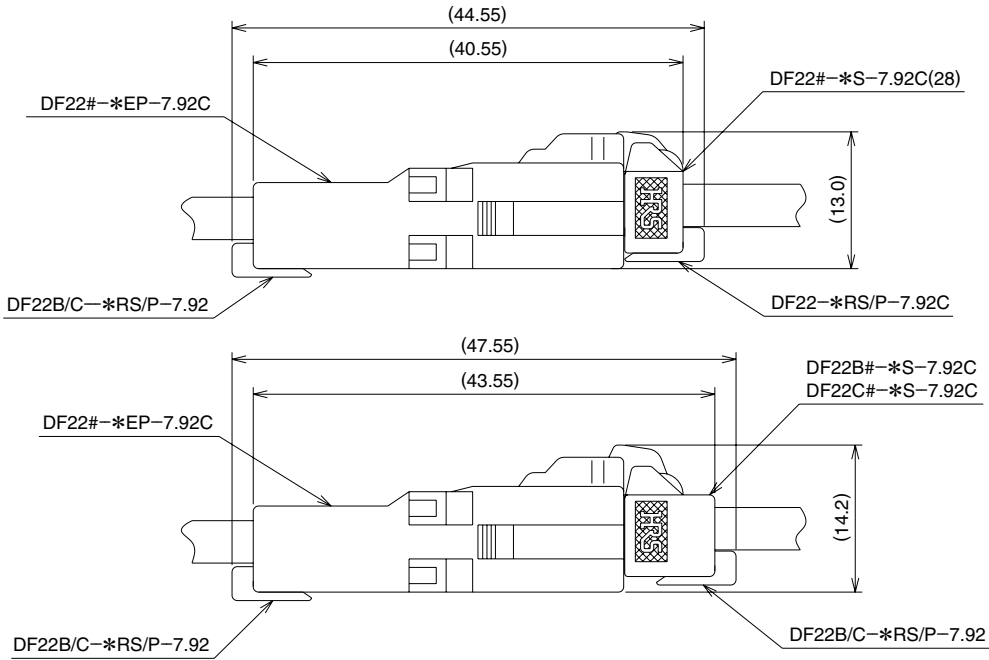

**●Socket to In-line Plug Connection**

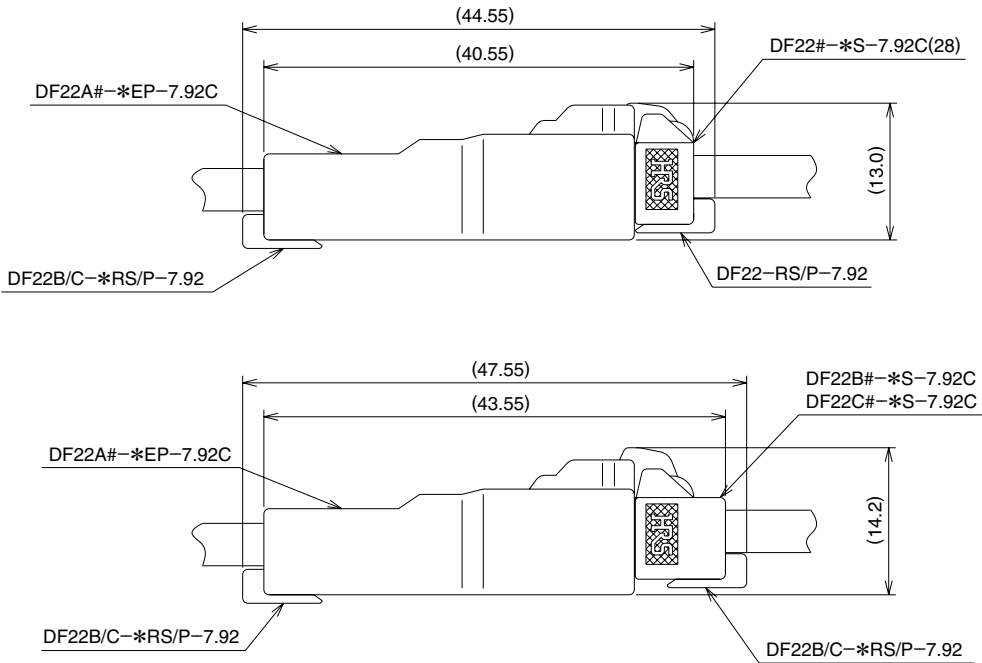

**DF22 Series 7.92 mm Contact Pitch, High Current Connectors for Internal Power Supplies (UL, C-UL and TUV Listed)**

**● In-line Double-row socket to In-line Double-row Plug (Panel mount type) Connection**

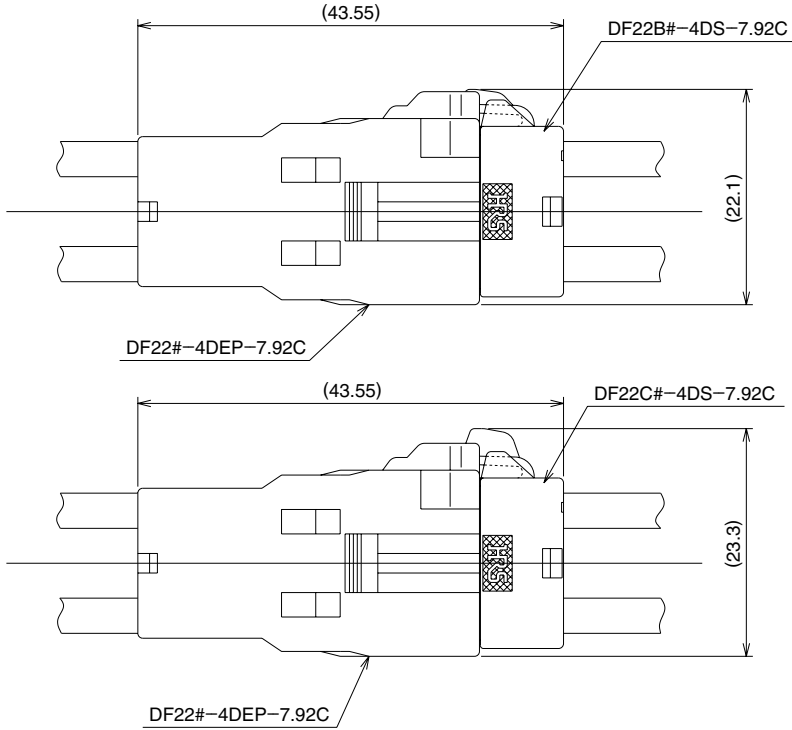

**● In-line Double-row socket to In-line Double-row Plug Connection**

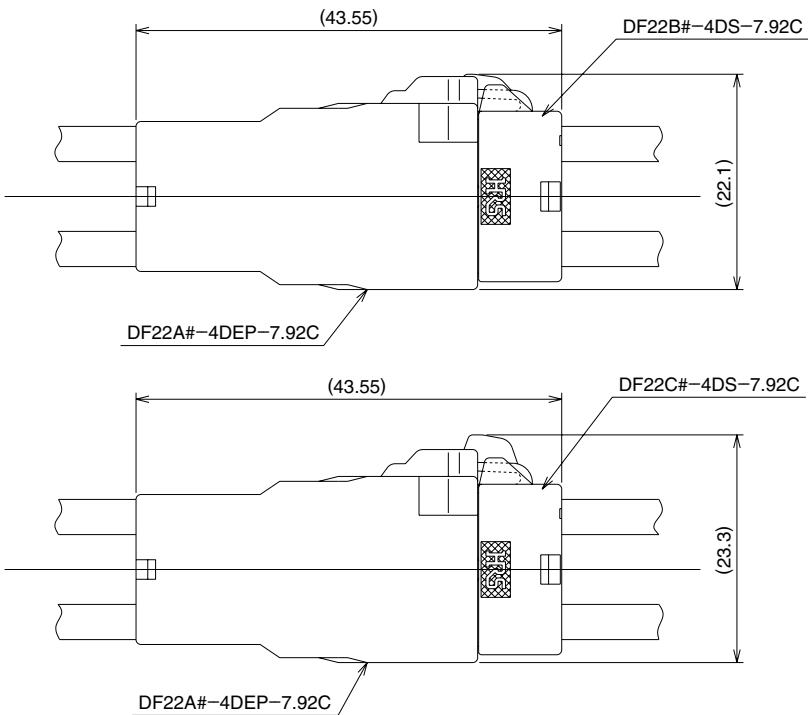



## ◆ Tools

Type	Item	Part Number	CL No.	Applicable Contacts
Automatic	Press unit	CM-105	901-0005-4	DF22/DF22A-1416SCF/PCF
	Applicators are used in automatic crimping machines manufactured by Hirose Electric	AP105-DF22-1416	901-4576-7	DF22-1416SCF/PCF
		AP105-DF22A-1416	901-4578-2	DF22A-1416SCF/PCF
		AP109A-DF22-1416	901-4579-5	DF22-1416SCF/PCF
	Applicators are used in automatic crimping machines manufactured by other companies	AP109A-DF22A-1416	901-4580-4	DF22A-1416SCF/PCF
		AP109A-DF22A-1012	901-4582-0	DF22A-1012SCF
Manual		Crimp tools	HT104/DF22-1416	550-0285-0
	HT104/DF22A-1416		550-0286-2	DF22A-1416SC/PC
	HT103/DF22A-1012		550-0288-8	DF22A-1012SC

Note 1: When crimping contact DF22A-1012SCF use a press with 3.5 ton min.

Note 2: AP109A type applicators cannot be used with the CM-105 press.

## ◆ Contact Extraction

■ Contact extraction tool: Flat-bladed screwdriver, 1.4 mm blade width

■ Intended crimp Contacts: DF22-1416SC(F), DF22A-1416SC(F), DF22A-1012SC(F), DF22-1416PC(F), and DF22A-1416PC(F)

■ Work Method

### Housing Cross-Sectional Diagram

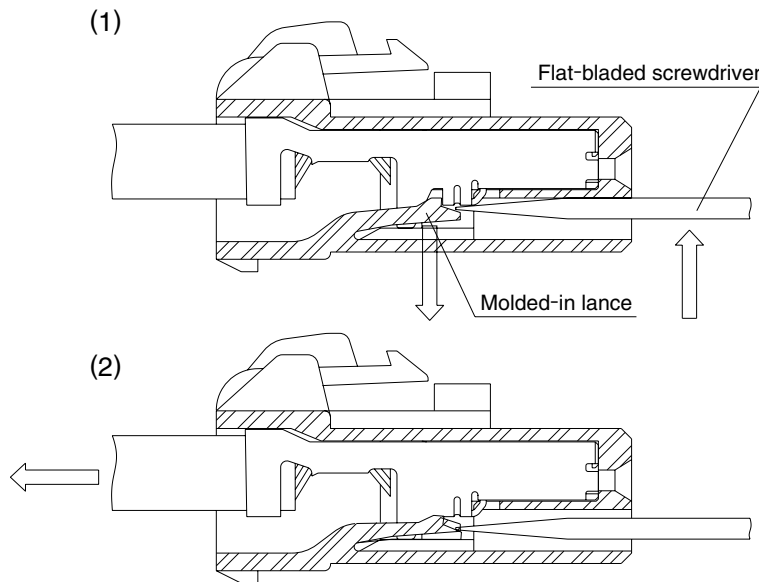

1. Refer to the drawing No. 1. Insert correct size screwdriver in the insulator against the molded-in lance. Deflect the lance as shown.

2. Assure that the lance is deflected to release the contact and pull-out wire with the terminated contact.

## ◆ Precautions

● Make sure that the lock is fully depressed before un-mating the connectors.

● Use correct size of the wires. Do NOT forcefully twist or deform wires, as this may affect the crimped contact connection.

## ◆ Current Ratings

The current rating listed in the catalog indicates the allowable current per contact. However, in applications requiring current transmission through all the contacts, about one-third of the listed rating should be applied. When the current rating for the connector is 3 A, and the allowable current of the conductor being used is 1 A, then rating of 1 A will be used for the entire assembly.

The connectors should not be mating / unmating when the electrical current is being applied.

Hot swap should not be performed.

## ◆ Usage Environment

Please contact us about use in equipment that is subjected to repetitive high temperature and low temperature environmental conditions.