

METALLIZED POLYESTER FILM CAPACITOR – MINI BOX

Suntan®

NON – INDUCTIVE, PLASTIC CASE AND EPOXY RESIN

TS05

FEATURES

- High reliability
- Box type provides the identical outer appearance

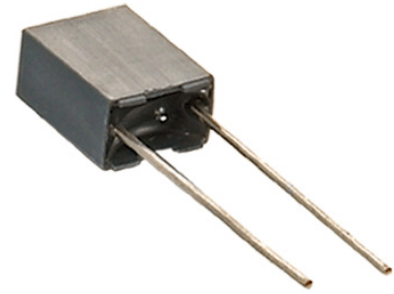

SPECIFICATIONS			
Reference Standard	GB7332 (IEC 60384-2)		
Climatic Category	55/100/56		
Rated Temperature	85°C		
Operating Temperature Range	-55°C~105°C (+85°C to +105°C : decreasing factor 1.25% per °C for V _R (DC))		
Rated Voltage	50V/63V, 100V, 250V, 400V, 500V, 630V		
Capacitance Range	0.0010μF ~ 1.5μF		
Capacitance Tolerance	±5%(J), ±10%(K), ±20%(M)		
Voltage Proof	Type A: 1.6U _R (5s) ; Type B: 1.4U _R (5s)		
Dissipation Factor	Frequency	C _R ≤ 0.1μF	C _R > 0.1μF
	1kHz	≤ 1.0%	≤ 1.0%
	10kHz	≤ 1.5%	≤ 1.5%
	100kHz	≤ 3.0%	--
Insulation Resistance	U _R > 100V	≥ 30 000MΩ, C _R ≤ 0.33μF (20°C, 100V, 1min)	
	U _R ≤ 100V	≥ 15 000MΩ, C _R ≤ 0.33μF	(20°C, 10V, 1min)
If the working voltage (U) is lower than the rated voltage (U _R), the capacitor can be worked at a higher dv / dt. In this case, the maximum allowed dv / dt is obtain by multiplying the right value with U _R / U	U _R (V)	dv / dt (V / μs)	
	50/63	250	
	100	300	
	250	400	
	400	600	
	500	700	
	630	800	

Outline Drawing

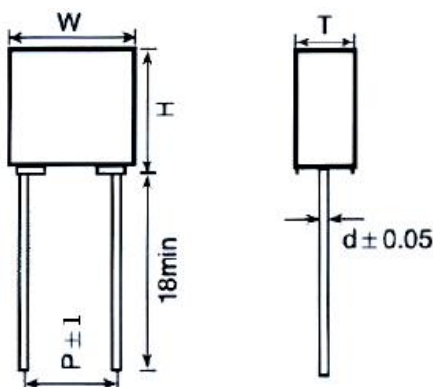

Dimensions (mm)

(Capacitor Thickness) T	≤ 3.5	> 3.5
(Lead Wire Diz.) d ± 0.05	0.5	0.6
(Dimension Tolerance: W, H, T)	± 0.2	± 0.4

METALLIZED POLYESTER FILM CAPACITOR – MINI BOX

Suntan®

NON – INDUCTIVE, PLASTIC CASE AND EPOXY RESIN

TS05

Type A (P:5mm)

(μF)	50/63VDC			100VDC			250VDC			400VDC			500VDC			630VDC		
	W	H	T	W	H	T	W	H	T	W	H	T	W	H	T	W	H	T
0.0010	7.2	6.5	2.5	7.2	6.5	2.5	7.2	6.5	2.5	7.2	6.5	2.5	7.2	6.5	2.5	7.2	6.5	2.5
0.0012	7.2	6.5	2.5	7.2	6.5	2.5	7.2	6.5	2.5	7.2	6.5	2.5	7.2	6.5	2.5	7.2	6.5	2.5
0.0015	7.2	6.5	2.5	7.2	6.5	2.5	7.2	6.5	2.5	7.2	6.5	2.5	7.2	6.5	2.5	7.2	6.5	2.5
0.0018	7.2	6.5	2.5	7.2	6.5	2.5	7.2	6.5	2.5	7.2	6.5	2.5	7.2	6.5	2.5	7.2	7.5	3.5
0.0022	7.2	6.5	2.5	7.2	6.5	2.5	7.2	6.5	2.5	7.2	6.5	2.5	7.2	6.5	2.5	7.2	7.5	3.5
0.0027	7.2	6.5	2.5	7.2	6.5	2.5	7.2	6.5	2.5	7.2	6.5	2.5	7.2	6.5	2.5	7.2	7.5	3.5
0.0033	7.2	6.5	2.5	7.2	6.5	2.5	7.2	6.5	2.5	7.2	6.5	2.5	7.2	7.5	3.5	7.2	7.5	3.5
0.0039	7.2	6.5	2.5	7.2	6.5	2.5	7.2	6.5	2.5	7.2	6.5	2.5	7.2	7.5	3.5	7.2	7.5	3.5
0.0047	7.2	6.5	2.5	7.2	6.5	2.5	7.2	6.5	2.5	7.2	6.5	2.5	7.2	7.5	3.5	7.2	9.5	4.5
0.0056	7.2	6.5	2.5	7.2	6.5	2.5	7.2	6.5	2.5	7.2	7.5	3.5	7.2	7.5	3.5	7.2	9.5	4.5
0.0068	7.2	6.5	2.5	7.2	6.5	2.5	7.2	6.5	2.5	7.2	7.5	3.5	7.2	9.5	4.5	7.2	9.5	4.5
0.0082	7.2	6.5	2.5	7.2	6.5	2.5	7.2	6.5	2.5	7.2	7.5	3.5	7.2	9.5	4.5	7.2	9.5	4.5
0.010	7.2	6.5	2.5	7.2	6.5	2.5	7.2	6.5	2.5	7.2	7.5	3.5	7.2	9.5	4.5	7.2	10.0	5.0
0.012	7.2	6.5	2.5	7.2	6.5	2.5	7.2	6.5	2.5	7.2	9.5	4.5	7.2	9.5	4.5	7.2	11.0	6.0
0.015	7.2	6.5	2.5	7.2	6.5	2.5	7.2	6.5	2.5	7.2	9.5	4.5	7.2	10.0	5.0	7.2	11.0	6.0
0.018	7.2	6.5	2.5	7.2	6.5	2.5	7.2	6.5	2.5	7.2	9.5	4.5	7.2	11.0	6.0	7.2	11.0	6.0
0.022	7.2	6.5	2.5	7.2	6.5	2.5	7.2	7.5	3.5	7.2	10.0	5.0	7.2	11.0	6.0	--	--	--
0.027	7.2	6.5	2.5	7.2	6.5	2.5	7.2	7.5	3.5	7.2	11.0	6.0	7.2	11.0	6.0	--	--	--
0.033	7.2	6.5	2.5	7.2	6.5	2.5	7.2	7.5	3.5	7.2	11.0	6.0	--	--	--	--	--	--
0.039	7.2	6.5	2.5	7.2	6.5	2.5	7.2	7.5	3.5	7.2	11.0	6.0	--	--	--	--	--	--
0.047	7.2	6.5	2.5	7.2	6.5	2.5	7.2	9.5	4.5	7.2	11.0	6.0	--	--	--	--	--	--
0.056	7.2	6.5	2.5	7.2	6.5	2.5	7.2	9.5	4.5	--	--	--	--	--	--	--	--	--
0.068	7.2	6.5	2.5	7.2	6.5	2.5	7.2	9.5	4.5	--	--	--	--	--	--	--	--	--
0.082	7.2	6.5	2.5	7.2	6.5	2.5	7.2	10.0	5.0	--	--	--	--	--	--	--	--	--
0.10	7.2	6.5	2.5	7.2	7.5	3.5	7.2	10.0	5.0	--	--	--	--	--	--	--	--	--
0.12	7.2	6.5	2.5	7.2	9.5	4.5	7.2	11.0	6.0	--	--	--	--	--	--	--	--	--
0.15	7.2	7.5	3.5	7.2	9.5	4.5	7.2	11.0	6.0	--	--	--	--	--	--	--	--	--
0.18	7.2	7.5	3.5	7.2	9.5	4.5	--	--	--	--	--	--	--	--	--	--	--	--
0.22	7.2	7.5	3.5	7.2	10.0	5.0	--	--	--	--	--	--	--	--	--	--	--	--
0.27	7.2	9.5	4.5	7.2	10.0	5.0	--	--	--	--	--	--	--	--	--	--	--	--
0.33	7.2	9.5	4.5	7.2	11.0	6.0	--	--	--	--	--	--	--	--	--	--	--	--
0.39	7.2	9.5	4.5	7.2	11.0	6.0	--	--	--	--	--	--	--	--	--	--	--	--
0.47	7.2	10.0	5.0	7.2	11.0	6.0	--	--	--	--	--	--	--	--	--	--	--	--
0.56	7.2	10.0	5.0	7.2	11.0	6.0	--	--	--	--	--	--	--	--	--	--	--	--
0.68	7.2	11.0	6.0	--	--	--	--	--	--	--	--	--	--	--	--	--	--	--
0.82	7.2	11.0	6.0	--	--	--	--	--	--	--	--	--	--	--	--	--	--	--
1.0	7.2	11.0	6.0	--	--	--	--	--	--	--	--	--	--	--	--	--	--	--

Type B (P:5mm)

(μF)	50/63VDC			100VDC			(μF)	50/63VDC			100VDC		
	W	H	T	W	H	T		W	H	T	W	H	T
0.10	--	--	--	7.2	6.5	2.5	0.39	7.2	7.5	3.5	7.2	9.5	4.5
0.12	--	--	--	7.2	6.5	2.5	0.47	7.2	7.5	3.5	7.2	10.0	5.0
0.15	7.2	6.5	2.5	7.2	7.5	3.5	0.56	7.2	9.5	4.5	7.2	10.0	5.0
0.18	7.2	6.5	2.5	7.2	7.5	3.5	0.68	7.2	9.5	4.5	7.2	11.0	6.0
0.22	7.2	6.5	2.5	7.2	7.5	3.5	0.82	7.2	9.5	4.5	7.2	11.0	6.0
0.27	7.2	6.5	2.5	7.2	9.5	4.5	1.0	7.2	10.0	5.0	7.2	11.0	6.0
0.33	7.2	7.5	3.5	7.2	9.5	4.5	1.5	7.2	11.0	6.0	--	--	--

Note: Specification are subject to change without notice. For more detail and update, please visit our website.