

POWER RELAY

1 POLE - 16A Silver Nickel Contact

FTR-K1 Series

RoHS compliant

■ FEATURES

- Suitable for low current load (silver nickel)
- Low profile (height: 15.7mm)
- HIGH ISOLATION
Insulation Distance (between coil and contacts): 10mm min.
Dielectric strength: 5KV
Surge strength: 10KV
- Low coil power (400mW)
- SAFETY STANDARDS
UL, CSA, VDE, SEMKO approved
UL, CSA TV-5 rating approved (1 form A type)
- RoHS Compliant
- UL F class isolation
- VDE Glow-wire ignitability test 775 (IEC60335-1) approved



■ ORDERING INFORMATION

[Example] FTR-K1 C K 005 W
 (a) (b) (c) (d) (e)

(a)	Series Name	FTR-K1: FTR-K1 Series			
(b)	Contact Arrangement	A	: 1 form A (SPST-NO)		
		C	: 1 form C (SPDT)		
(c)	Coil Type / Enclosure	K	: Standard (400 mW) / flux free		
(d)	Nominal Voltage	005	: 5 VDC,	006 : 6VDC,	009 : 9VDC
		018	: 18 VDC	022 : 022VDC	024 : 24VDC,
		048	: 48VDC	028	: 28VDC
(e)	Contact Material	E	: AgNi		

Actual marking does not carry the type name : "FTR"

E.g.: Ordering code: FTR-K1CK012W

Actual marking: K1CK012W

FTR-K1 SERIES

■ PART NUMBERS

400mW type

Ordering Part Number	Series	Contact	Coil Power	Coil Voltage	Contact Material
FTR-K1AK005E	FTR-K1	A: 1 form A	K: 400 mW	5	E: AgNi
FTR-K1AK006E				6	
FTR-K1AK009E				9	
FTR-K1AK012E				12	
FTR-K1AK018E				18	
FTR-K1AK022E				22	
FTR-K1AK024E				24	
FTR-K1AK028E				28	
FTR-K1AK048E				K: 430 mW	
FTR-K1CK005E		C: 1 form C	K: 400 mW	5	
FTR-K1CK006E				6	
FTR-K1CK009E				9	
FTR-K1CK012E				12	
FTR-K1CK018E				18	
FTR-K1CK022E				22	
FTR-K1CK024E				24	
FTR-K1CK028E				28	
FTR-K1CK048E				K: 430 mW	

■ COIL DATA CHART

Coil Voltage	Nominal Voltage (VDC)	Max. Coil Voltage*1	Coil Resistance (±10%)	Must Operate Voltage*2	Must Release Voltage*2	Nominal Power (mW)
005	5	12.2 VDC	62 Ω	3.5 VDC	0.5 VDC	400
006	6	14.7 VDC	90 Ω	4.2 VDC	0.6 VDC	
009	9	22.0 VDC	202 Ω	6.3 VDC	0.9 VDC	
012	12	29.4 VDC	360 Ω	8.4 VDC	1.2 VDC	
018	18	44.1 VDC	810 Ω	12.6 VDC	1.8 VDC	
022	22	53.9 VDC	1,210 Ω	15.4 VDC	2.2 VDC	
024	24	58.8 VDC	1,440 Ω	16.8 VDC	2.4 VDC	
028	28	68.6 VDC	1,960 Ω	19.6 VDC	2.8 VDC	
048	48	117.6 VDC	5,360 Ω	33.6 VDC	4.8 VDC	430

Note: All values in the table are measured at 20°C.

*1: No contact current at 20°C

*2: Specified values are subject to pulse wave voltage

FTR-K1 SERIES

■ SPECIFICATIONS

Item		FTR-K1 AK () E	FTR-K1 CK () E	
Contact	Arrangement	1 form A	1 form C	
	Material	AgNi		
	Resistance (initial)	Maximum 100 mΩ at 1 A, 6 VDC		
	Rating	16 A, 250 VAC / 24 VDC		
	Maximum Carrying Current*1	20 A		
	Maximum Switching Rating	4,000 VA / 384W		
	Maximum Switching Voltage	440 VAC / 300VDC		
	Minimum Switching Load*2	10 mA 5 VDC		
Coil	Nominal Power (at 20°C)	400mW (at 430mW 48V coil)		
	Operate Power (at 20°C)	200 mW (210mW at 48V coil)		
	Operating Temperature	-40°C to +85°C (no frost)		
Time Value	Operate (without diode)	Maximum 15ms (at nominal voltage, no bounce)		
	Release (without diode)	Maximum 5ms (at nominal voltage, no bounce)		
Life	Mechanical	20 x 10 ⁶ operations minimum		
	Electrical	AC Contact rating	100 x 10 ³ operations min.	50 x 10 ³ operations min.
		DC contact rating	100 x 10 ³ operations min.	30 x 10 ³ operations min.
Other	Vibration Resistance	Misoperation	10 to 55 Hz, at double amplitude of 0.7 mm	
		Endurance	10-55Hz, at double amplitude of 1.5 mm	
	Shock Resistance	Misoperation	Min. 100m/s ² (11±1ms)	
		Endurance	Min. 1,000m/s ² (6±1ms)	
	Weight	Approximately 13g		

*1 Need to consider the heat from PCB when max. current is more than 10A.

*2 Minimum switching loads mentioned above are reference values. Please perform the confirmation test with the actual load before production since reference values may vary according to switching frequencies, environmental conditions and expected reliability levels.

FTR-K1 SERIES

■ INSULATION

Item	FTR-K1	Note
Resistance (initial)	Minimum 1,000 MΩ 1 min.	at 500 VDC
Dielectric Strength	open contacts	1,000 VAC (50/60 Hz) 1 min.
	coil and contacts	5,000 VAC (50/60 Hz) 1 min.
Surge Voltage (coil and contact)	10,000 V	1.2 x 50µs standard wave
Clearance/Creepage	10 mm / 10 mm	
Insulation (DIN EN61810-1 VDE0435)		
Voltage	250 V	
Pollution	3	
Isolation material group	IIIa	
Isolation category / Reference voltage (VDE0110b)	C / 250 V	

■ SAFETY STANDARDS

Type	Compliance	Contact rating	
		FTR-K1CK () E	FTR-K1AK () E
UL	UL 508	Flammability: UL 94-V0 (plastics)	
	E63614	16A, 277VAC/24VDC (resistive) 20A, 277VAC (resistive) 1 HP, 277VAC 1/2 HP, 125VAC 1/8 HP, 125VAC Pilot duty: B300	16A, 277VAC/24 VDC (resistive) 20A, 277 VAC (resistive) 1 HP, 277VAC 1/2 HP, 125VAC Pilot duty: A300
CSA	C22.2 No. 14 LR 40304	16A, 277VAC/24VDC (resistive) 1 HP, 277VAC 1/2 HP, 125VAC 1/8 HP, 125VAC Pilot duty: B300	16A, 277VAC/24 VDC (resistive) 1 HP, 277VAC 1/2 HP, 125VAC Pilot duty: A300
VDE	0435, 0631, 0700, 0860, 40013848	16A, 250 VAC (cosØ=1), 85°C 3.5A, 250 VAC (cosØ=0.4), 85°C 16 A 24VDC (0ms), 85°C	
SEMKO	EN 61058-1:1992 and A1 EN 61095:1993 and A1+A11	250VAC, 16 (3)A 40T85	

Complies with NEMKO, DEMKO, FIMKO

FTR-K1 SERIES

CHARACTERISTIC DATA

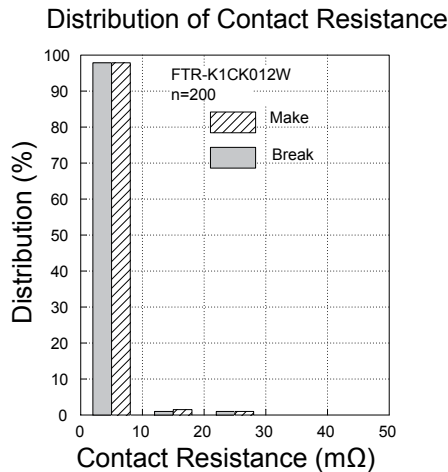
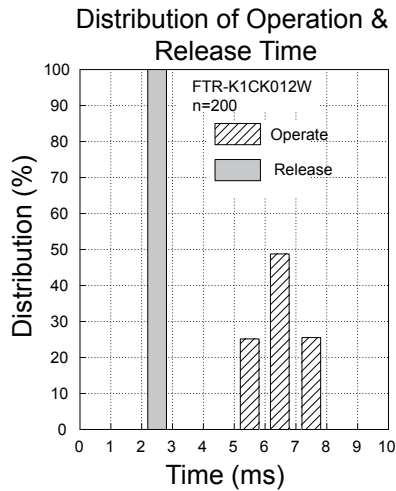
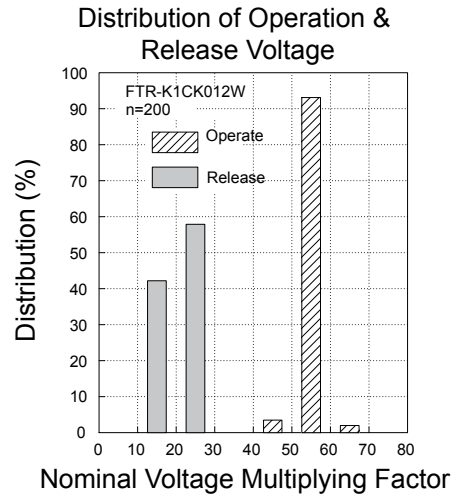
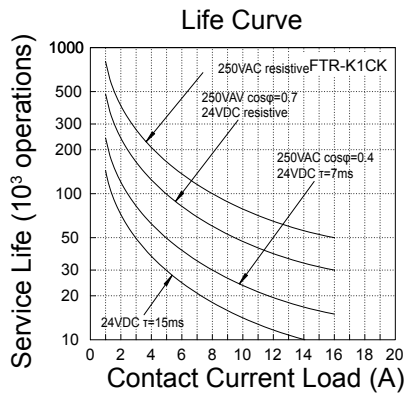
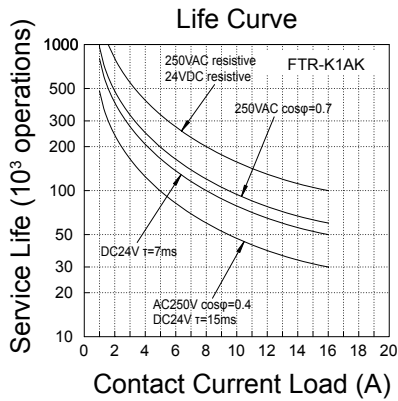
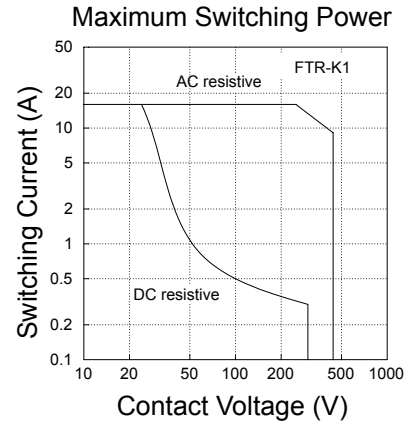
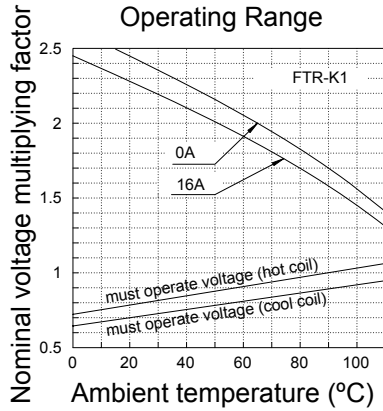
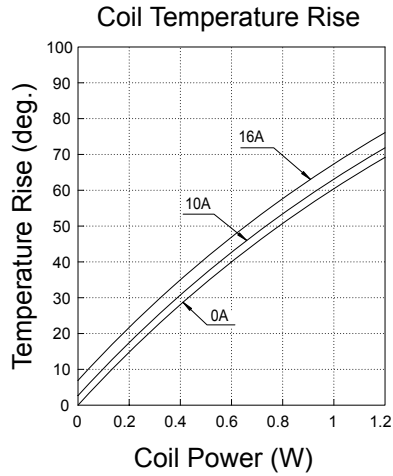

FTR-K1 SERIES

■ DIMENSIONS

● Dimensions

FTR-K1AK () E

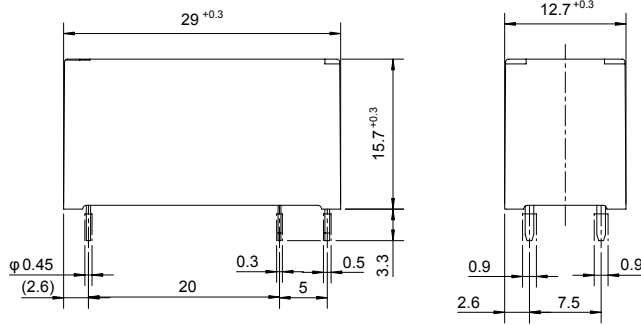

● Schematics (BOTTOM VIEW)

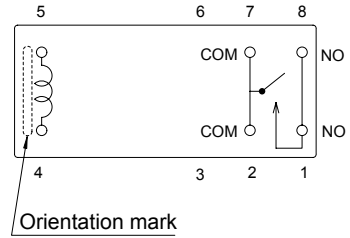

● PC board mounting hole layout (BOTTOM VIEW)

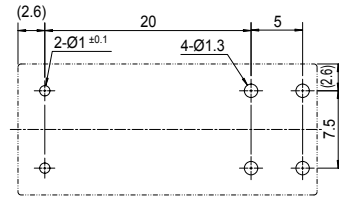

● Dimensions

FTR-K1CK () E

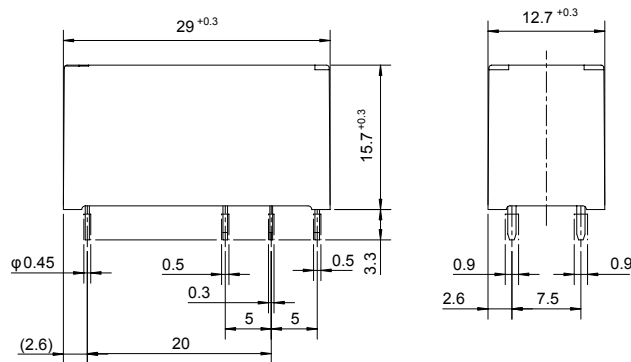

● Schematics (BOTTOM VIEW)

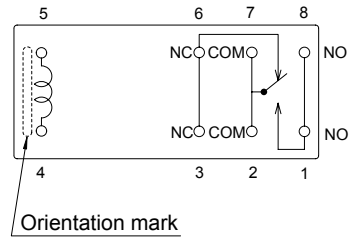

● PC board mounting hole layout (BOTTOM VIEW)

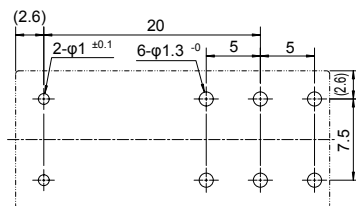

Unit: mm

RoHS Compliance and Lead Free Relay Information

1. General Information

- Relays produced after the specific date code that is indicated on each data sheet are lead-free now. All of our signal and power relays are lead-free. Please refer to Lead-Free Status Info. (<http://www.fujitsu.com/us/downloads/MICRO/fcai/relays/lead-free-letter.pdf>)
 - Lead free solder paste currently used in relays is Sn-3.0Ag-0.5Cu.
 - All signal and power relays also comply with RoHS. Please refer to individual data sheets. Relays that are RoHS compliant do not contain the 5 hazardous materials that are restricted by RoHS directive (lead, mercury, chromium IV, PBB, PBDE, DecaBDE).
 - It has been verified that using lead-free relays in leaded assembly process will not cause any problems (compatible).
 - "LF" is marked on each outer and inner carton. (No marking on individual relays).
- Note: Cadmium was exempted from RoHS on October 21, 2005. (Amendment to Directive 2002/95/EC)

2. Recommended Lead Free Solder Profile

- Recommended solder paste Sn-3.0Ag-0.5Cu.

Solder condition

Flow Solder condition:

Pre-heating: maximum 120°C
Soldering: dip within 5 sec. at
260°C solder bath

Solder by Soldering Iron:

Soldering Iron
Temperature: maximum 360°C
Duration: maximum 3 sec.

We highly recommend that you confirm your actual solder conditions

3. Moisture Sensitivity

- Moisture Sensitivity Level standard is not applicable to electromechanical relays.

4. Tin Whisker

- Dipped SnAgCu solder is known as low risk tin whisker. No considerable length whisker was found by our in house test.

Fujitsu Components International Headquarter Offices

Japan

Fujitsu Component Limited
Gotanda-Chuo Building
3-5, Higashigotanda 2-chome, Shinagawa-ku
Tokyo 141, Japan
Tel: (81-3) 5449-7010
Fax: (81-3) 5449-2626
Email: promothq@ft.ed.fujitsu.com
Web: www.fcl.fujitsu.com

North and South America

Fujitsu Components America, Inc.
250 E. Caribbean Drive
Sunnyvale, CA 94089 U.S.A.
Tel: (1-408) 745-4900
Fax: (1-408) 745-4970
Email: components@us.fujitsu.com
Web: <http://www.fujitsu.com/us/services/edevices/components/>

Europe

Fujitsu Components Europe B.V.
Diamantlaan 25
2132 WV Hoofddorp
Netherlands
Tel: (31-23) 5560910
Fax: (31-23) 5560950
Email: info@fceu.fujitsu.com
Web: emea.fujitsu.com/components/

Asia Pacific

Fujitsu Components Asia Ltd.
102E Pasir Panjang Road
#01-01 Citilink Warehouse Complex
Singapore 118529
Tel: (65) 6375-8560
Fax: (65) 6273-3021
Email: fcal@fcal.fujitsu.com
Web: <http://www.fujitsu.com/sg/services/micro/components/>

©2009 Fujitsu Components America, Inc. All rights reserved. All trademarks or registered trademarks are the property of their respective owners.

Fujitsu Components America or its affiliates do not warrant that the content of datasheet is error free. In a continuing effort to improve our products Fujitsu Components America, Inc. or its affiliates reserve the right to change specifications/datasheets without prior notice.
Rev. January 30, 2009.