

TS128M~2GMMC

MultiMediaCard

Description

TS128MMC ~ TS2GMMC is a 128MB ~ 2GB MultiMediaCard. It's a highly integrated with flash memory, and is accessed via a dedicated serial interface optimized for fast and reliable data transmission. It is designed to provide an inexpensive, mechanically robust storage medium in card form for multimedia consumer applications and mobile devices (handheld PCs, digital cameras, MP3 players, etc.) to store, copy, and move information like a small hard drive.

Placement



Front

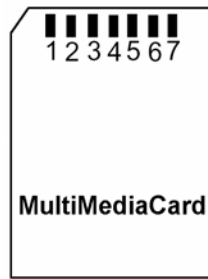

Back

Features

- Storage Capacity: 128MB ~ 2GB
- Operating Voltage: 2.7 ~ 3.6V
- Operating Temperature: -25°C ~ 85°C
- Fully compatible with MultiMediaCard system specification version 3.x
- Embedded data error correction
- Low power consumption
- Form Factor: 32mm x 24mm x 1.4mm

Pin Definition

Pin No.	MMC Mode			SPI Mode		
	Name	Type	Description	Name	Type	Description
1	RSV	NC	Reserved	CS	I	Chip select
2	CMD	I/O/PP/OD	Command/Response	DI	I/PP	Data in
3	VSS1	S	Ground	VSS	S	GND
4	VCC	S	Power supply	VDD	S	VCC
5	CLK	I	Clock	SCLK	I	Clock
6	VSS2	S	Ground	VSS2	S	GND
7	DAT	I/O/PP	Data	DO	O/PP	Data out

S: Power Supply; I:Input; O:Output; PP:Push-Pull; OD:Open-Drain; NC:Not Connected

TS128M~2GMMC

MultiMediaCard

MultiMediaCard Architecture

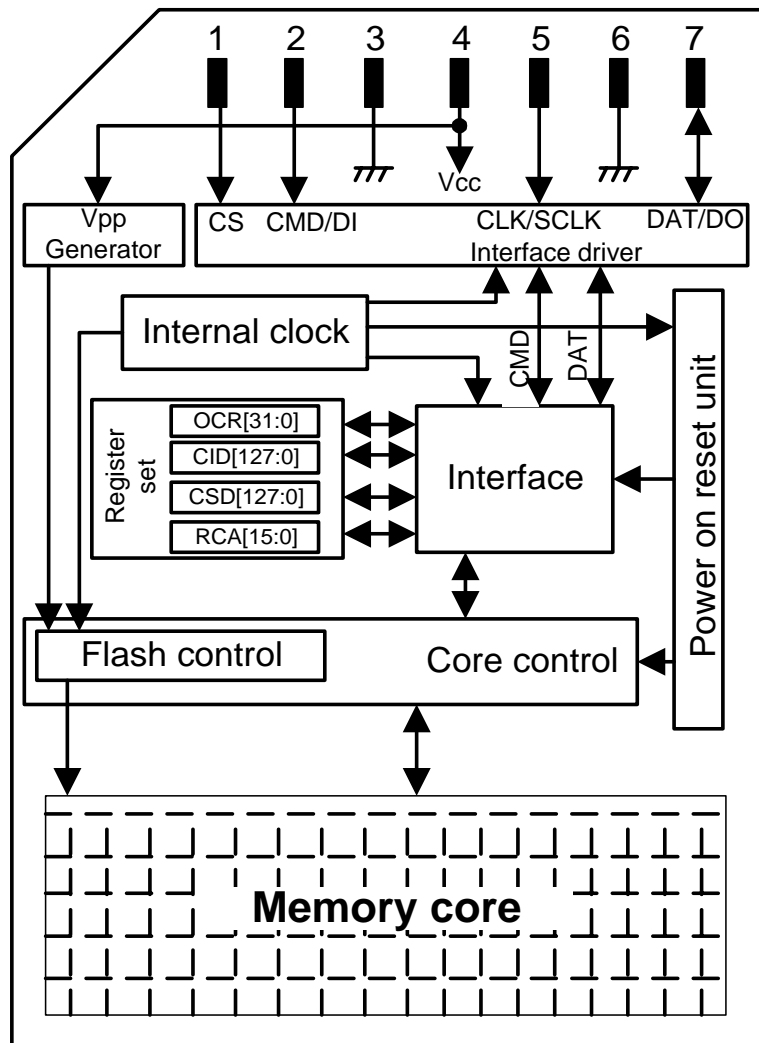

Temperature Characteristics

Parameter	Min.	Max.	Unit
Operating temperature	-25	85	°C

Electrical Characteristics

• Absolute Maximum Ratings

Parameter	Symbol	Rating	Unit
Power Supply Voltage	V_{CC}	-0.6~+4.6	V
Input Voltage	V_{IN}	-0.6~+4.6	V
Input/Output Voltage	V_{IO}	-0.6~+4.6	V

• Recommended Operation Conditions

Parameter	Symbol	Min.	Typ.	Max.	Unit
Power Supply Voltage	V_{DDH}	2.7	3.3	3.6	V

DC Characteristics

• Power Supply

(Ta=-25°C to 85°C, V_{DDH}=2.7V to 3.6V)

Parameter	Symbol	Min.	Typ.	Max.	Unit	Condition
Output Low Voltage (OD)	V _{ODOL}			0.3	V	I _{OL} = 2mA
Output High Voltage (PP)	V _{OH}	0.75* V _{DDH}			V	I _{OH} = -100uA
Output Low Voltage (PP)	V _{OL}			0.125* V _{DDH}	V	I _{OL} = 100uA
Input High Voltage	V _{IH}	0.625* V _{DDH}		V _{DDH} + 0.3	V	
Input Low Voltage	V _{IL}	-0.3		0.25* V _{DDH}	V	
Operating Current	I _{CC}			20(TBD)	mA	I _{VCCF} = 0mA
Stand-by Current	I _{SB}			400(TBD)	uA	
Input Leakage Current	I _{LI}			-10/+10	uA	V _{IN} = 0 to V _{DDH}
Output Leakage Current	I _{LO}			-10/+10	uA	V _{OUT} = 0 to V _{DDH}
Pin Capacitance	C _P			7	pF	
Power Output Voltage	V _F	1.50	1.8	1.95	V	I _F < = 240mA

AC Characteristics

• Card Interface Timing

($T_a = -25^{\circ}\text{C}$ to 85°C , $V_{DDH} = 2.7\text{V}$ to 3.6V)

Parameter	Symbol	Min.	Max.	Unit	Notes
Clock Frequency (Data Transfer Mode)	f_{pp}	0	20	MHz	
Clock Frequency (Identification Mode)	f_{OD}	0	400	KHz	
Clock Low Time	t_{WL}	10		ns	
Clock Rise Time	t_{TLH}		10	ns	
Clock Fall Time	t_{THL}		10	ns	
Input Set-up Time	t_{ISU}	3		ns	
Input Hold Time	t_{IH}	3		ns	
Output Delay Time	t_{DLY}	9.7	35	ns	$C_L \leq 30\text{pF}$

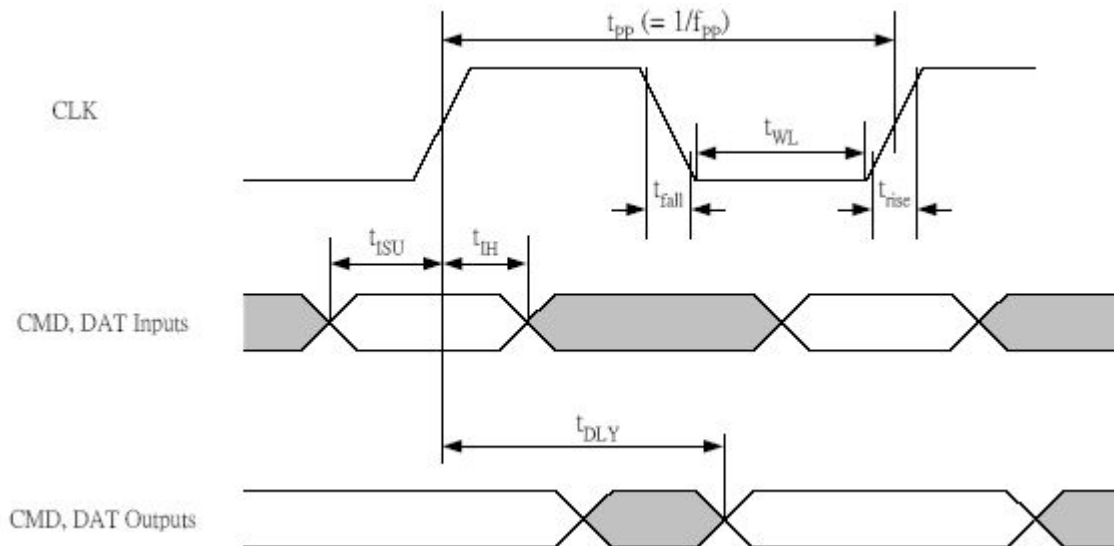

• Command Latch Cycle

Parameter	Symbol	Min.	Unit	Notes
CLE Setup Time	t_{CLS1}	30	ns	$C_L \leq 80\text{pF}$
CLE Hold Time	t_{CLH1}	15	ns	$C_L \leq 80\text{pF}$
CE Setup Time	t_{CS1}	40	ns	$C_L \leq 80\text{pF}$
CE Hold Time	t_{CH1}	90	ns	$C_L \leq 80\text{pF}$
ALE Setup Time	t_{ALS1}	90	ns	$C_L \leq 80\text{pF}$
ALE Hold Time	t_{ALH1}	75	ns	$C_L \leq 80\text{pF}$
WE Pulse Width	t_{WP1}	45	ns	$C_L \leq 80\text{pF}$
Data Setup Time	t_{DS1}	90	ns	$C_L \leq 80\text{pF}$
Data Hold Time	t_{DH1}	30	ns	$C_L \leq 80\text{pF}$

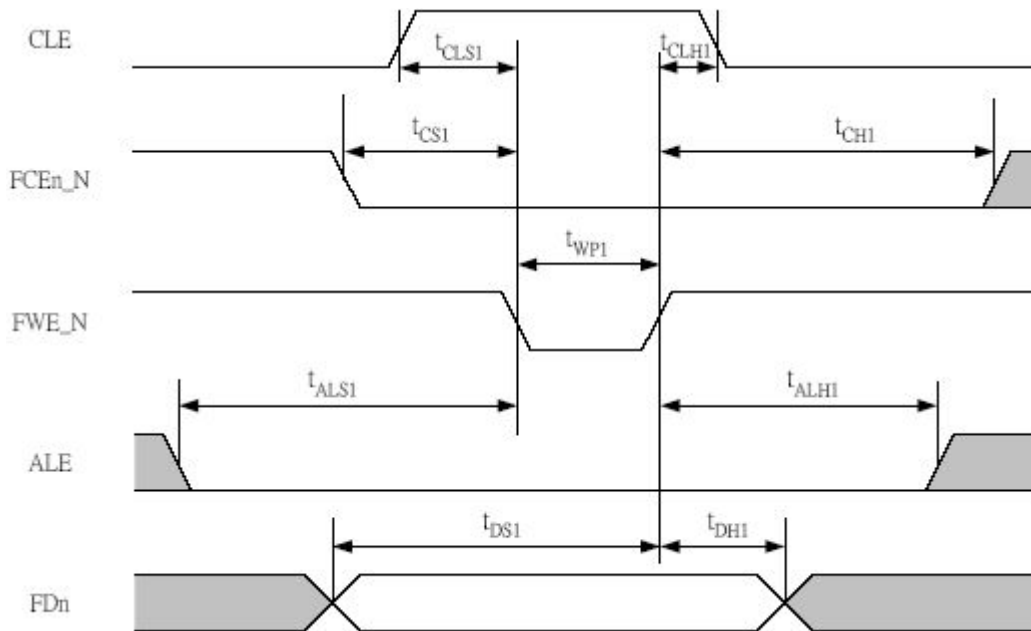

• Address Latch Cycle

Parameter	Symbol	Min.	Unit	Remark
CLE Setup Time	t_{CLS2}	90	ns	$C_L \leq 80\text{pF}$
CE Setup Time	t_{CS2}	195	ns	$C_L \leq 80\text{pF}$
ALE Setup Time	t_{ALS2}	30	ns	$C_L \leq 80\text{pF}$
ALE Hold Time	t_{ALH2}	15	ns	$C_L \leq 80\text{pF}$
Write Cycle Time	t_{WC2}	150	ns	$C_L \leq 80\text{pF}$
WE Pulse Width	t_{WP2}	45	ns	$C_L \leq 80\text{pF}$
WE High Hold Time	t_{WH2}	105	ns	$C_L \leq 80\text{pF}$
Data Setup Time	t_{DS2}	90	ns	$C_L \leq 80\text{pF}$
Data Hold Time	t_{DH2}	30	ns	$C_L \leq 80\text{pF}$

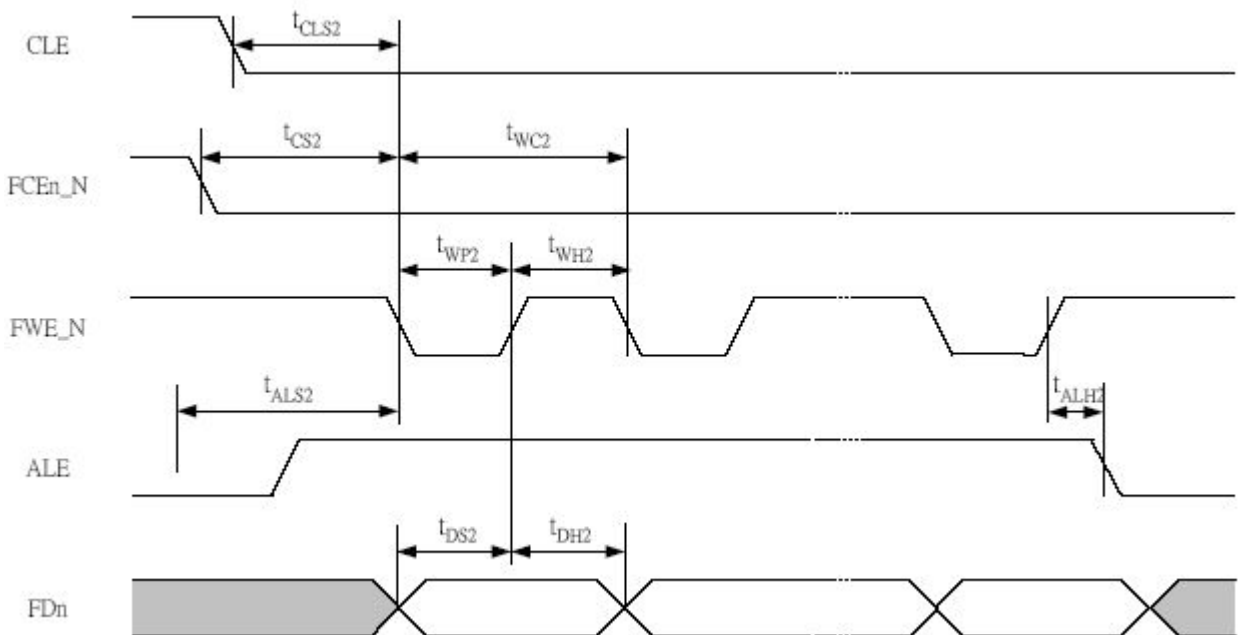

• Input Data Latch Cycle

Parameter	Symbol	Min.	Unit	Remark
CLE Hold Time	t_{CLH3}	285	ns	$C_L \leq 80\text{pF}$
CE Hold Time	t_{CH3}	195	ns	$C_L \leq 80\text{pF}$
ALE Setup Time	t_{ALS3}	90	ns	$C_L \leq 80\text{pF}$
Write Cycle Time	t_{WC3}	60	ns	$C_L \leq 80\text{pF}$
WE Pulse Width	t_{WP3}	45	ns	$C_L \leq 80\text{pF}$
WE High Hold Time	t_{WH3}	15	ns	$C_L \leq 80\text{pF}$
Data Setup Time	t_{DS3}	30	ns	$C_L \leq 80\text{pF}$
Data Hold Time	t_{DH3}	30	ns	$C_L \leq 80\text{pF}$

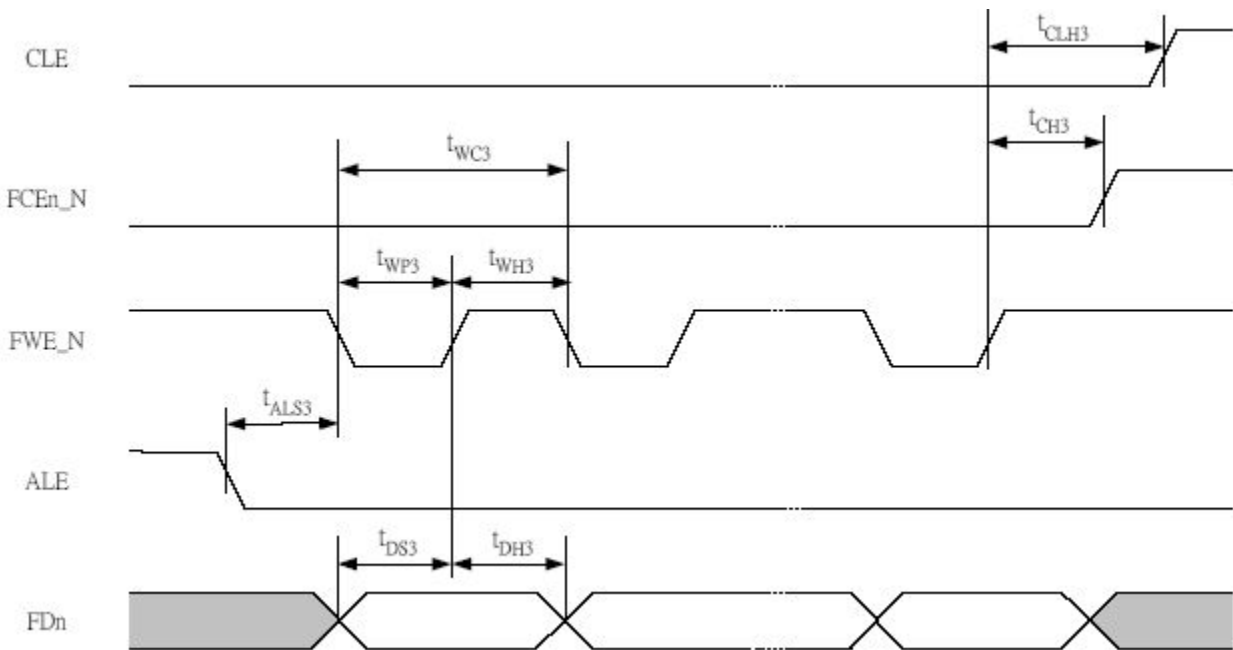

• Serial Access Cycle after Read

Parameter	Symbol	Min.	Unit	Remark
CE Access Time	t_{CEA4}	285	ns	$C_L \leq 80pF$
Read Cycle Time	t_{RC4}	60	ns	$C_L \leq 80pF$
RE Pulse Width	t_{RP4}	45	ns	$C_L \leq 80pF$
RE High Hold Time	t_{REH4}	15	ns	$C_L \leq 80pF$
Data Setup Time	t_{DS4}	5(TBD)	ns	$C_L \leq 80pF$
Data Hold Time	t_{DH4}	5(TBD)	ns	$C_L \leq 80pF$
Ready to RE Low	t_{RR4}	285	ns	$C_L \leq 80pF$

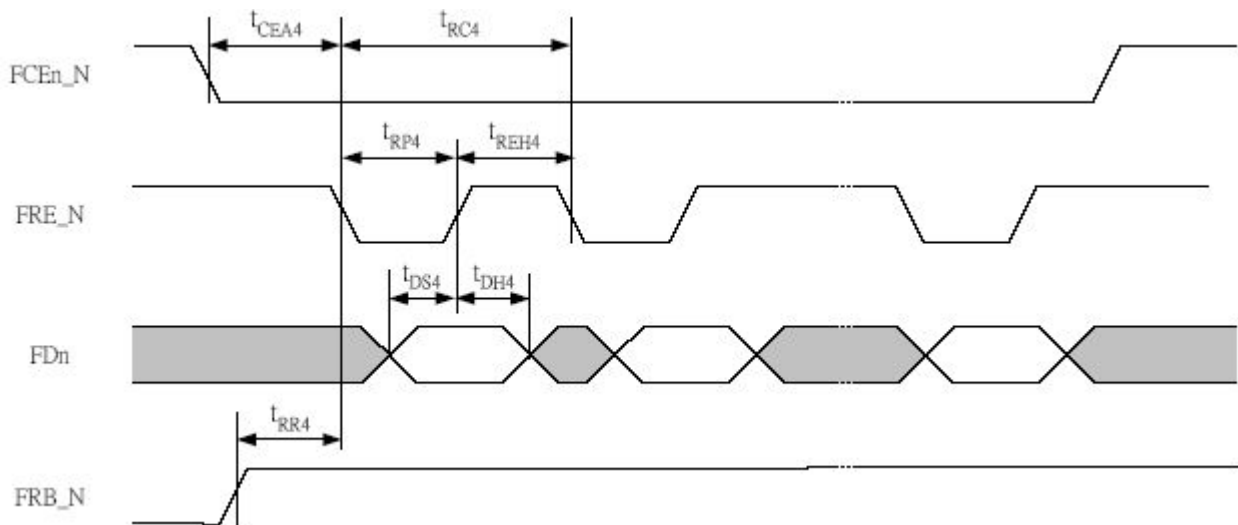

Reliability and Durability

Temperature	Operation: -25°C / 85°C Storage: -40°C (168h) / 85°C (500h) Junction temperature: max. 95°C
Moisture and corrosion	Operation: 25°C / 95% rel. humidity Stress: 40°C / 93% rel. hum./500h Salt Water Spray: 3% NaCl/35C; 24h acc. MIL STD Method 1009
ESD protection	Contact Pads: +/-4kV, Human body model according to ANSI EOS/ESD-S5.1-1998 Non Contact Pads area: +/-8kV(coupling plane discharge) +/-15kV(air discharge) Human body model according to IEC61000-4-2
Durability	10.000 mating cycles; test procedure: t.b.d.
Bending	t.b.d.
Torque	t.b.d.
Drop test	1.5m free fall
UV light exposure	UV: 200nm, 15Ws/cm ² according to ISO 7816-1
Visual inspection Shape and form	No warp page; no mold skin; complete form; no cavities surface smoothness sigma -0.1 mm/cm ² within contour; no cracks; no pollution (fat, oil dust, etc.)

Above technical information is based on MMC.3 31 standard specification and tested to be reliable. However, Transcend makes no warranty, either expressed or implied, as to its accuracy and assumes no liability in connection with the use of this product. Transcend reserves the right to make changes in specifications at any time without prior notice.