

1.5A Low Dropout Positive Regulator

FEATURES

- Dropout Voltage 1.3V at 1.5A Output Current.
- Fast Transient Response.
- Line Regulation typically at 0.015%.
- Load Regulation typically at 0.1%.
- Current Limiting and Thermal Protection.
- Adjustable Output Voltage or Fixed 1.8V, 2.5V, 2.85V, 3.3V, 5V.
- Standard 3-Pin Power Packages.

APPLICATIONS

- Post Regulator for Switching Supply.
- Battery Chargers.
- Constant-Current Regulators.
- PC Add-On Card.

DESCRIPTION

The SS6086 is a low dropout three terminal regulator with 1.5A output current capability. The output voltage is adjustable with the use of a resistor divider or fixed 1.8V, 2.5V, 2.85V, 3.3V, 5V. Dropout voltage is guaranteed to be a maximum of 1.5V with the maximum output current. Its low dropout voltage and fast transient response make it ideal for low voltage microprocessor applications. Internal current limit and thermal limit provide protection against any overload condition that would create excessive junction temperatures.

TYPICAL APPLICATION CIRCUIT

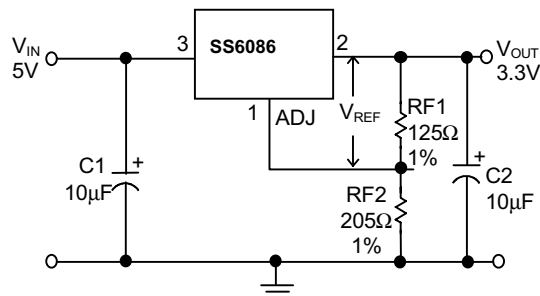

Adjustable Voltage Regulator

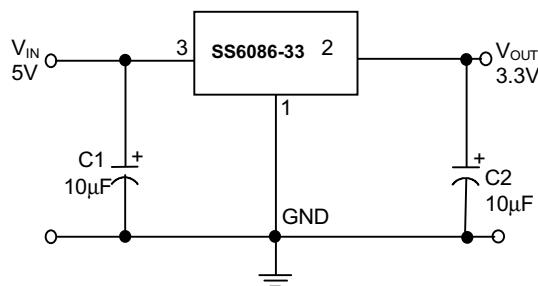

Fixed Voltage Regulator

$$V_{REF} = V_{OUT} - V_{ADJ} = 1.25V \text{ (typ.)}$$

$$V_{OUT} = V_{REF} \times (1 + RF2/RF1) + I_{ADJ} \times RF2$$

$$I_{ADJ} = 55\mu A \text{ (typ.)}$$

- (1) C1 needed if device is far away from filter capacitors.
- (2) C2 required for stability.

ORDERING INFORMATION

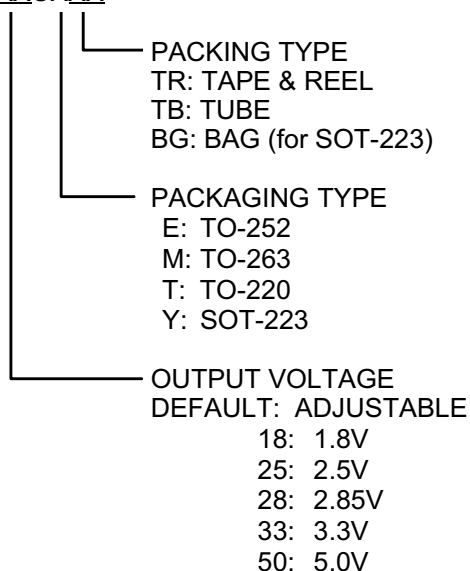
SS6086-XXCXXX

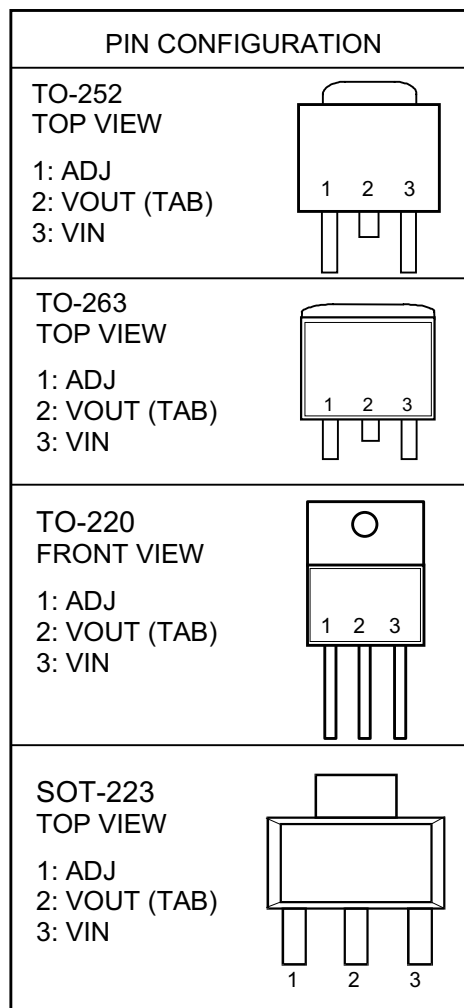
 Example: **SS6086-28CETR**

 → 2.85V version in TO-252 Package &
Taping & Reel Packing Type

ABSOLUTE MAXIMUM RATINGS

VIN pin to ADJ/ GND pin	7V
Operating Junction Temperature Range	0°C ~ 125°C
Storage Temperature Range	-65°C ~ 150°C
Thermal Resistance (Junction to Case) TO-220	3°C/W
TO-252	12.5°C/W
SOT-223	15°C/W
TO-263	3°C/W
Thermal Resistance Junction to Ambient TO-252	100°C/W
(Assume no ambient airflow, no heatsink) TO-263	60°C/W
SOT-223	155°C/W
TO-220	50°C/W
Lead Temperature (Soldering) 10 sec.	260°C

■ **ELECTRICAL CHARACTERISTICS** ($V_{IN}=5V$, $T_J=25^{\circ}C$, $I_O=10mA$, Unless otherwise specified)

PARAMETER	TEST CONDITIONS	MIN.	TYP.	MAX.	UNIT
Reference Voltage	SS6086 (Adj.) $T_J=25^{\circ}C$	1.238	1.25	1.262	V
	$0^{\circ}C \leq T_J \leq 125^{\circ}C$	1.225	1.25	1.275	
Output Voltage	SS6086-18, $V_{IN}=3.3V$	1.78	1.80	1.82	V
	SS6086-25, $V_{IN}=5V$	2.47	2.50	2.53	
	SS6086-28, $V_{IN}=5V$	2.82	2.85	2.88	
	SS6086-33, $V_{IN}=5V$	3.26	3.30	3.33	
	SS6086-50, $V_{IN}=7V$	4.95	5.00	5.05	
Line Regulation	$2.75 \leq V_{IN} \leq 7V$, $V_{OUT}=1.25V$				%
	$T_J=25^{\circ}C$		0.015	0.2	
	$0^{\circ}C \leq T_J \leq 125^{\circ}C$		0.035	0.2	
Load Regulation	$T_J=25^{\circ}C$, $I_O=10mA \sim 1.5A$ $0^{\circ}C \leq T_J \leq 125^{\circ}C$		0.1 0.2	0.3 0.4	%
Dropout Voltage	ΔV_{OUT} , $\Delta V_{REF}=1\%$ $I_O=1.5A$ $0^{\circ}C \leq T_J \leq 125^{\circ}C$		1.3	1.5	V
Current Limit	$0^{\circ}C \leq T_J \leq 125^{\circ}C$	1.5	2.0		A
Adjusted Pin Current (I_{ADJ})	$2.75 \leq V_{IN} \leq 7V$ $10mA \leq I_O \leq 1.5A$ $0^{\circ}C \leq T_J \leq 125^{\circ}C$		55	120	μA
Adjusted Pin Current Change (ΔI_{ADJ})	$2.75 \leq V_{IN} \leq 7V$ $10mA \leq I_O \leq 1.5A$ $0^{\circ}C \leq T_J \leq 125^{\circ}C$		0.2	5	μA
Temperature Stability	$I_O=0.5A$ $0^{\circ}C \leq T_J \leq 125^{\circ}C$		0.5		%
Minimum Load Current	$0^{\circ}C \leq T_J \leq 125^{\circ}C$		5	10	mA
RMS Output Noise (% of V_{OUT})	$10Hz \leq f \leq 10KHz$		0.003		%
Ripple Rejection Ratio	120Hz input ripple $C_{OUT}=25\mu F$	60	72		dB

TYPICAL PERFORMANCE CHARACTERISTICS

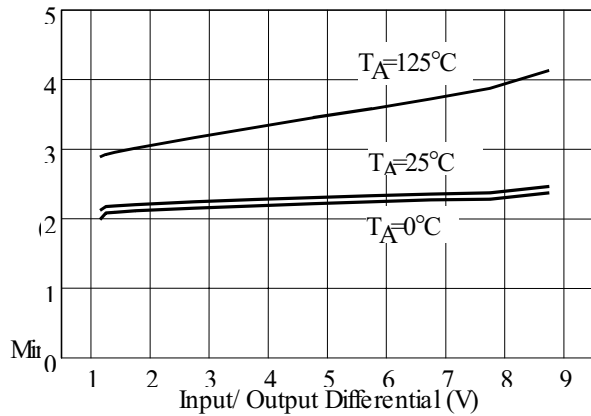

Fig. 1 SS6086 Min. Load C current (Adjustable Version)

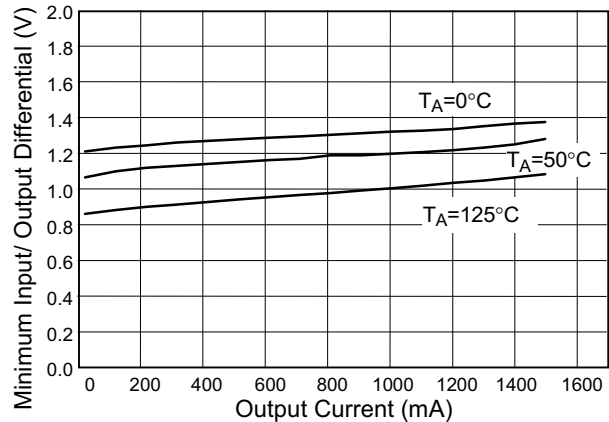

Fig. 2 SS6086 Drop out Voltage

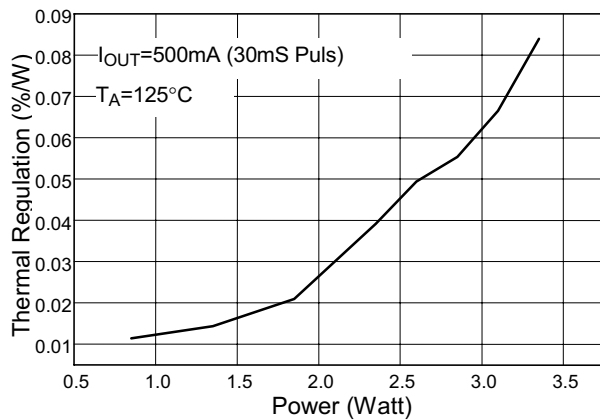

Fig. 3 SS6086 (ADJ) Power vs. Thermal Regulation

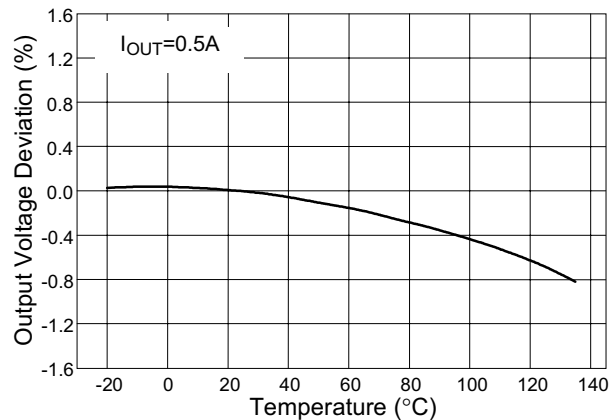

Fig. 4 SS6086 (ADJ) Temperature Stability

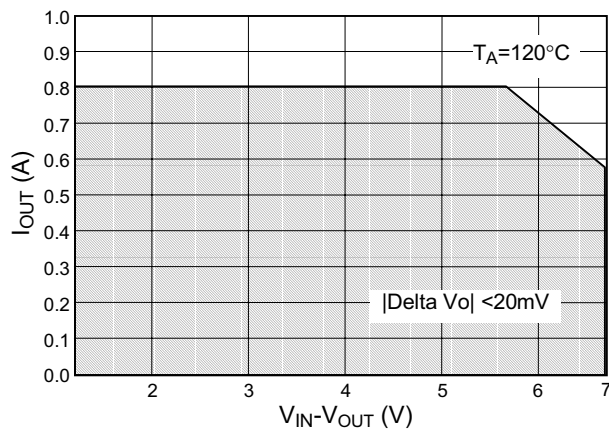

Fig. 5 SS6086 (ADJ) Maximum Output Current vs. V_{IN}-V_{OUT}

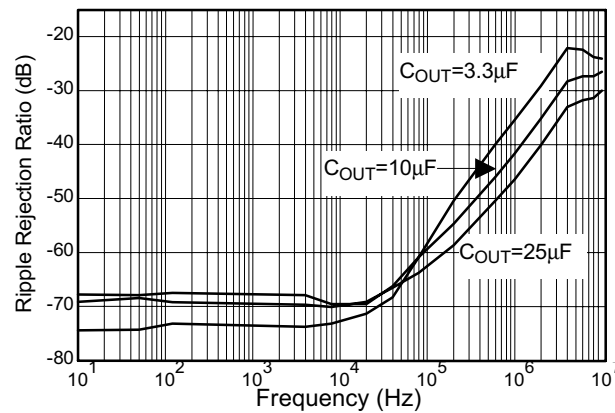

Fig. 6 SS6086 (ADJ) Ripple Rejection Ratio

■ TYPICAL PERFORMANCE CHARACTERISTICS (Continued)

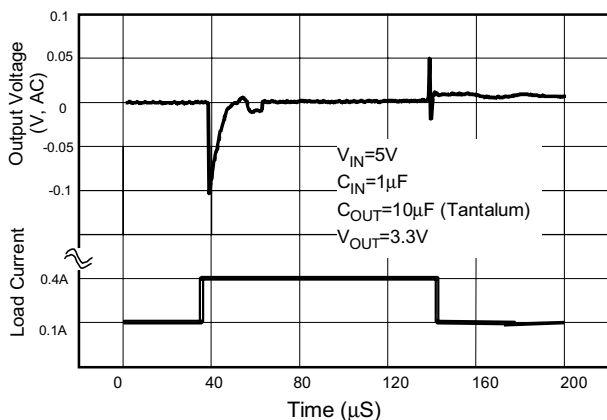

Fig. 7 Load Transient Response

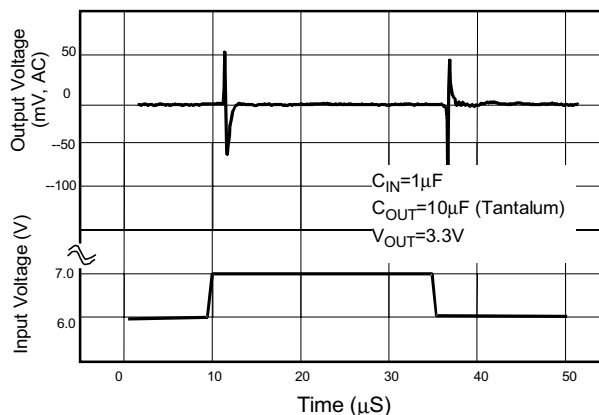
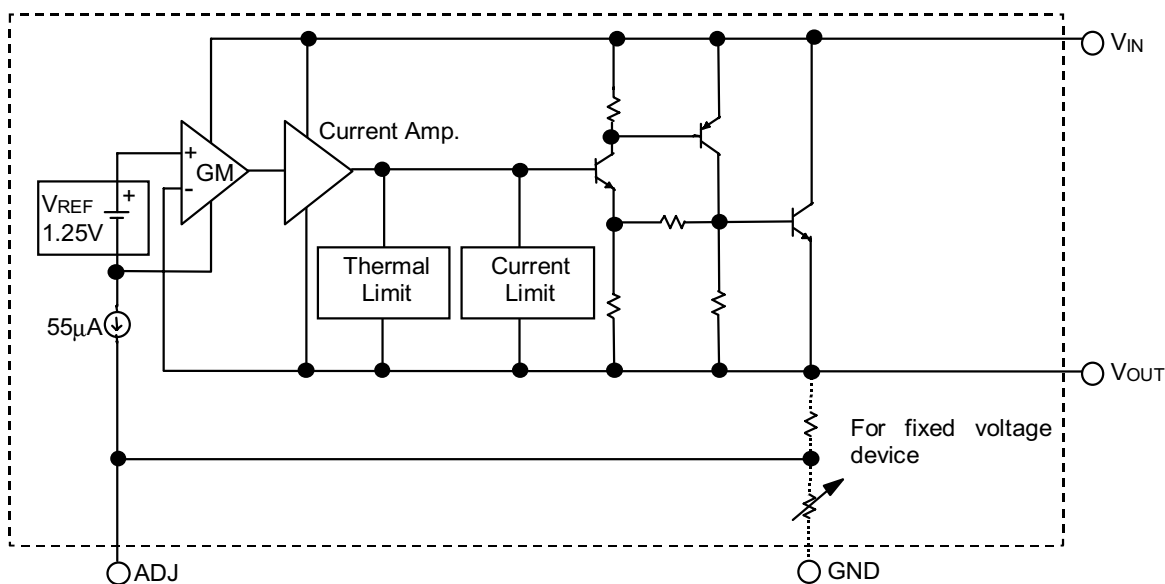

Fig. 8 Line Transient Response

■ BLOCK DIAGRAM



■ PIN DESCRIPTIONS

- ADJ PIN - Providing $V_{REF}=1.25V$ (typ.) for adjustable V_{OUT} . $V_{REF}=V_{OUT}-V_{ADJ}$ and $I_{ADJ}=55\mu A$ (typ.)
- GND PIN - Power ground.
- VOUT PIN - Adjustable output voltage.
- VIN PIN - Power Input.

■ PHYSICAL DIMENSIONS

● TO-220 (unit: mm)

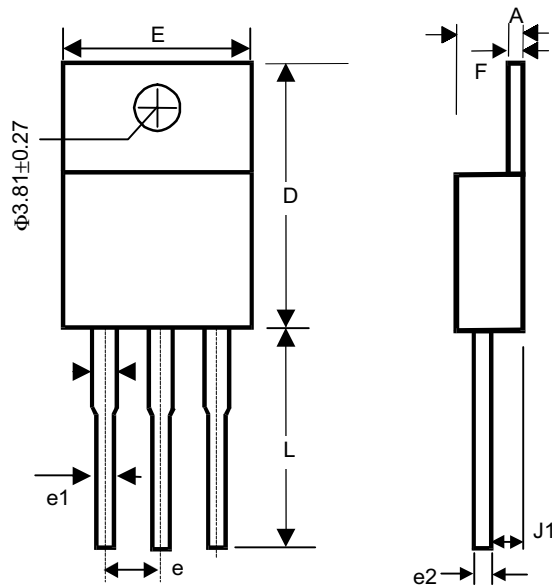

SYMBOL	MIN	MAX
A	3.56	4.82
D	14.23	16.51
E	9.66	10.66
e	2.29	2.79
e1	0.50	1.15
e2	-	1.10
F	0.51	1.39
J1	2.04	2.92
L	12.70	14.73

● TO-252 (unit: mm)

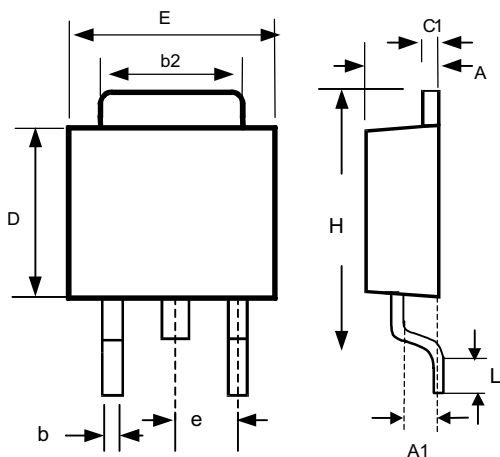

SYMBOL	MIN	MAX
A	2.19	2.38
A1	1.02	1.27
b	0.64	0.88
b2	5.21	5.46
C1	0.46	0.58
D	5.33	5.59
E	6.35	6.73
e	2.28 (TYP.)	
H	9.40	10.42
L	0.51	-

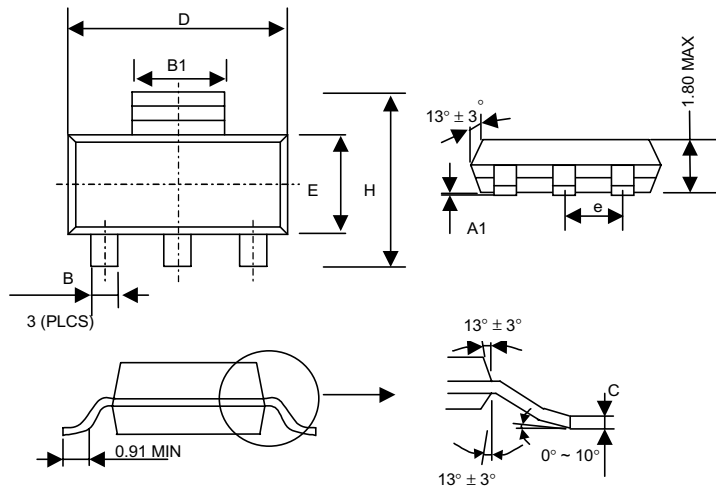
● SOT-223

SYMBOL	MIN	MAX
A1	0.02	0.12
B	0.60	0.80
B1	2.90	3.15
C	0.24	0.35
D	6.30	6.80
E	3.30	3.70
e	2.30 (TYP.)	
H	6.70	7.30

● SOT-223 Marking

Part No.	Marking
SS6086	1086
SS6086-18 CY	AX18
SS6086-25 CY	AX25
SS6086-28 CY	AX28
SS6086-33 CY	AX33
SS6086-50 CY	AX50

Information furnished by Silicon Standard Corporation is believed to be accurate and reliable. However, Silicon Standard Corporation makes no guarantee or warranty, express or implied, as to the reliability, accuracy, timeliness or completeness of such information and assumes no responsibility for its use, or for infringement of any patent or other intellectual property rights of third parties that may result from its use. Silicon Standard reserves the right to make changes as it deems necessary to any products described herein for any reason, including without limitation enhancement in reliability, functionality or design. No license is granted, whether expressly or by implication, in relation to the use of any products described herein or to the use of any information provided herein, under any patent or other intellectual property rights of Silicon Standard Corporation or any third parties.