

PRELIMINARY DATA SHEET

3.7GBS 1310NM PIN+PREAMP ROSA

PIN-1310-2I-LCA

FEATURES:

- LC ROSA
- High performance InGaAs PIN photodiode with separate transimpedance amplifier
- Low electrical parasitic TO46package
- Data rates from DC to 4Gbps
- DC coupled outputs
- A separate detector bias pin which can be used for receive power monitoring
- Low bias currents and voltages
- Automatic gain control for wide dynamic range operation
- Designed for specifically for video applications
- Capable of handling 3G SDI pathological test signals

The PIN-1310-2I-LCA is designed specifically for use in video applications and is capable of handling 3G SDI pathological test signals. Consisting of a high-performance InGaAs PIN photo-detector packaged with a transimpedance amplifier designed to meet performance requirements for data rates up to 2.5Gbps data communication over single-mode optical fiber at 1200nm to 1600nm.

Other applications include Ethernet, Fiber Channel and ATM protocols.



Part Number	Description
PIN-1310-2I-LCA	1310nm 5 pin LC ROSA, with separate PD bias for RSSI , DC coupled output

Finisar

Advanced Optical Components Division

ABSOLUTE MAXIMUM RATINGS

Parameter	Rating
Storage Temperature	-40 to +85°C
Case Operating Temperature	-40 to +85°C
Lead Solder Temperature	260°C, 10 sec.
Power Supply Voltage	-0.5V to 4V
Incident Optical Power	+1 dBm average, +4 dBm peak
ESD exposure level (human body level)	50V

NOTICE: Stresses greater than those listed under “Absolute Maximum Ratings” may cause permanent damage to the device. This is a stress rating only and functional operation of the device at these or any other conditions above those indicated in the operations section for extended periods of time may affect reliability.

NOTICE: The inherent design of this component causes it to be sensitive to electrostatic discharge (ESD). To prevent ESD-induced damage and/or degradation to equipment, take normal ESD precautions when handling this product.



ELECTRO-OPTICAL CHARACTERISTICS

3.0V<V_{CC}<3.6V, AC coupled to 50Ω (100Ω differential), 20°C<T<85°C unless otherwise specified

VCSEL Parameters	Test Condition	Symbol	Min.	Typ.	Max.	Units	Notes
Data Rate		DR	0.15		2.5	Gbps	
Supply Voltage		V _{CC}	3.0	3.3	3.6	V	
PD Bias Voltage		PD _{BIAS}	V _{CC} - 0.5	V _{CC}	V _{CC} +0.5		
Supply Current	P _R =0μW, R _L =50Ω AC coupled	I _{CC}		26	40	mA	1
Optical Return Loss	P _R =-12dBm	ORL	12			dB	1
Input Optical Wavelength		λ _p	1200	1310	1600	nm	
Maximum Input Power before Overload		P _{MAX}	0			dBm	
Differential Output Voltage Swing	P _{R,OMA} = -12Bm, AC Coupled to R _L =50Ω	V _{o(pk-pk)}	50	150	400	mV	1,2
Differential Responsivity	P _{R,OMA} = -12dBm, AC Coupled to R _L =50Ω	R	1300	2800		V/W	1,2
-3dB Optical/Electrical Bandwidth	P _{R,OMA} = -12dBm	BW	1.6			GHz	1,2,3
Output Impedance		Z _{OUT}	42	50	58	Ω	
Output Return Loss	F<3GHz	S ₂₂	8	12		dB	
Sensitivity, OMA	DR = 2.5Gbps	S			-20	dBm	4
Rise/Fall Time	P _{R,OMA} = -12dBm, (20%-80%)	T _R /T _F		200		ps	2,5
Power Supply Rejection Ratio	P _R =0μW (Dark), 5MHz<F<2GHz	PSRR	20			dB	1,6
PD Responsivity	P _R =-12dBm	I _{MON}	0.7	0.8	0.95	A/W	7
PD Offset Current	P _R =0mW	I _{OFFSET}			50	nA	7
AGC Attack Time		T _{AGC/A}			TBD	ms	
AGC Decay Time		T _{AGC/D}			TBD	ms	
Sensitivity, OMA	DR = 2.5Gbps	S			-20	dBm	4
Rise/Fall Time	P _{R,OMA} = -12dBm, (20%-80%)	T _R /T _F		200		ps	2,5
PD Capacitance	V _R = 0V, Freq = 1MHz V _R = 3V, Freq = 1MHz	C		75 40	100 55	pF	

NOTES

- P_R is the average optical power at the fiber face.
- P_{R,OMA} is the peak to peak optical power at the fiber face (Optical Modulation Amplitude)

$$P_{R,OMA} \equiv \frac{2P_R(ER-1)}{ER+1}$$
 where ER is the extinction ratio (linear) of the optical source.
- Bandwidth and Low Frequency Cutoff are measured with a small signal sinusoidal light source with -12dBm average power
- Sensitivity is measured with an optical source with an extinction ratio of 6dB.
- Rise/Fall times are corrected for optical source Rise/Fall times. $T_{TIA}^2 = T_{MEASURED}^2 - T_{OPTICAL}^2$
- Value shown is with no external power supply filtering.
- The monitor current slope is measured as the current into the PD_{BIAS} connection. PD Offset current is defined as the maximum current measured at V_{PD} with no optical input.

INTERFACE CONFIGURATION:

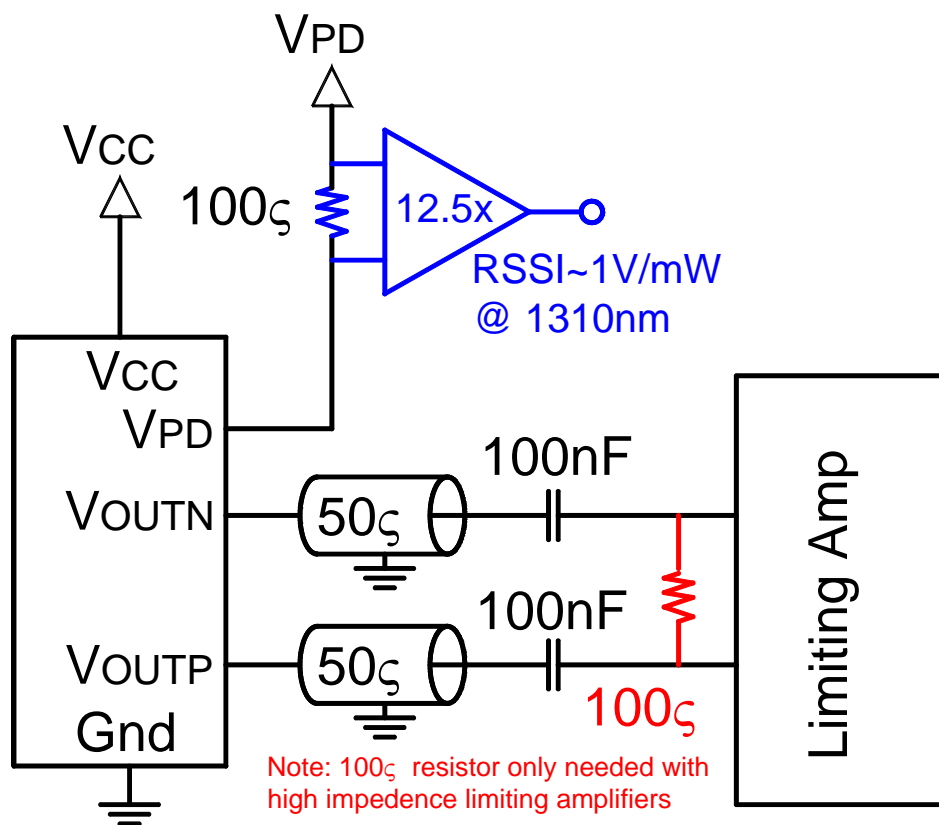

Optional RSSI implementation is shown in blue.

Optional 100 differential termination for high impedance limiting amplifiers is shown in red.

Recommended bias filter network

Note, better performance will be obtained if a ferrite bead is used in place of the inductor.

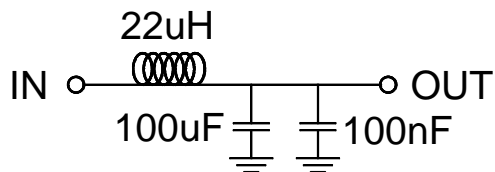

MOUNTING DIMENSIONS, LC ROSA

for reference only, dimensions in inches

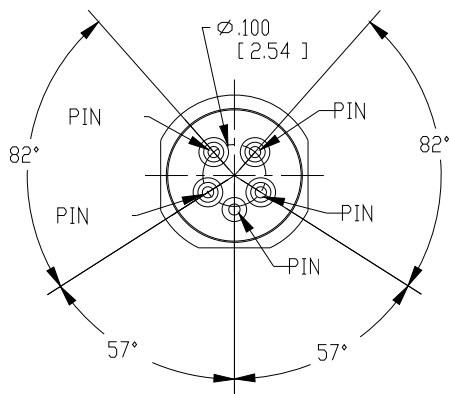
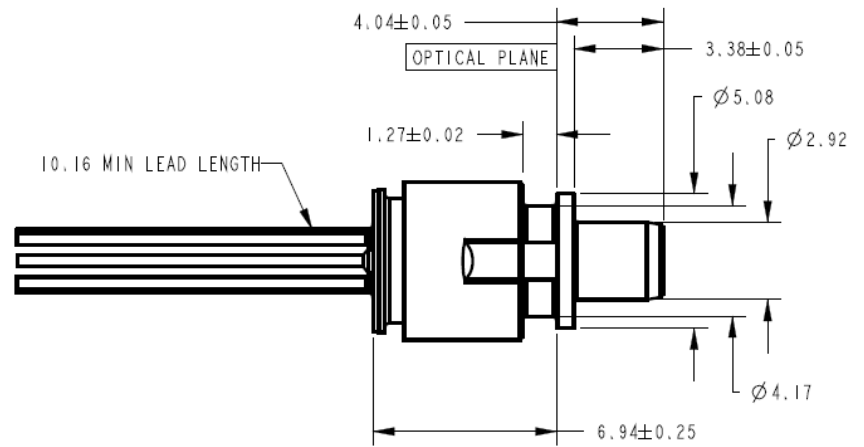
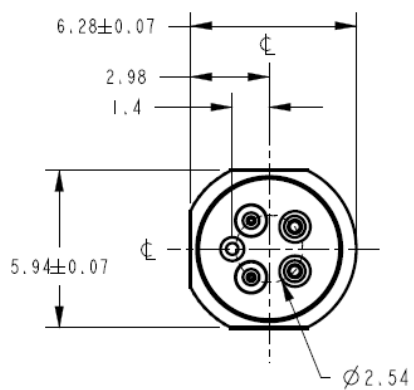

ADVANCED OPTICAL COMPONENTS

Finisar's ADVANCED OPTICAL COMPONENTS division was formed through strategic acquisition of key optical component suppliers. The company has led the industry in high volume Vertical Cavity Surface Emitting Laser (VCSEL) and associated detector technology since 1996. VCSELs have become the primary laser source for optical data communication, and are rapidly expanding into a wide variety of sensor applications. VCSELs' superior reliability, low drive current, high coupled power, narrow and circularly symmetric beam and versatile packaging options (including arrays) are enabling solutions not possible with other optical technologies. ADVANCED OPTICAL COMPONENTS is also a key supplier of Fabry-Perot (FP) and Distributed Feedback (DFB) Lasers, and Optical Isolators (OI) for use in single mode fiber data and telecommunications networks

LOCATION

- Allen, TX - Business unit headquarters, VCSEL wafer growth, wafer fabrication and TO package assembly.
- Fremont, CA - Wafer growth and fabrication of 310 to 1550nm FP and DFB lasers.
- Shanghai, PRC - Optical passives assembly, including optical isolators and splitters.

SALES AND SERVICE

Finisar's ADVANCED OPTICAL COMPONENTS division serves its customers through a worldwide network of sales offices and distributors. For application assistance, current specifications, pricing or name of the nearest Authorized Distributor, contact a nearby sales office or call the number listed below.

AOC CAPABILITIES

ADVANCED OPTICAL COMPONENTS' advanced capabilities include:

- 1, 2, 4, 8, and 10Gbps serial VCSEL solutions
- 1, 2, 4, 8, and 10Gbps serial SW DETECTOR solutions
- VCSEL and detector arrays
- 1, 2, 4, 8, and 10Gbps FP and DFB solutions at 1310 and 1550nm
- 1, 2, 4, 8, and 10Gbps serial LW DETECTOR solutions
- Optical Isolators from 1260 to 1600nm range
- Laser packaging in TO46, TO56, and Optical subassemblies with SC, LC, and MU interfaces for communication networks
- VCSELs operating at 670nm, 780nm, 980nm, and 1310nm in development
- Sensor packages include surface mount, various plastics, chip on board, chip scale packages, etc.
- Custom packaging options

Phone: 1-866-MY-VCSEL USA (toll free)
 1-972-792-1800 USA (Direct dial)
 44 (0) 174 336 5533 Europe
 886-935-409898 China & Taiwan
 81-90-4437-1130 Japan

Fax: 1-972-238-8670 USA
 44 (0) 979 445 2047 Europe
 03 5440-1368 Asia

Finisar
 Advanced Optical Components Division

Email: support@adopco.com
 WEB: www.finisar.com/aoc.php