

Series 804 Hermetic Receptacles



Series 804 Hermetic
Jam Nut Mount

Series 804 Hermetic Receptacles feature 304L stainless steel shells, fused vitreous glass insulators and gold-plated Alloy 52 iron alloy contacts.

1 X 10⁻⁶ cc/second maximum helium leak rate when tested at 1 atmosphere vacuum.

Two Shell Styles are available:
Style 00 for front panel mounting, and
Style 07 for rear panel mounting.

Solder Cup Contacts accept up to #22 AWG stranded wire. Or, choose **Printed Circuit Board Contacts** for attachment to rigid boards or flexible circuits.

HOW TO ORDER					
Sample Part Number					
804-006	-07	Z1	9-19	P	A
Series	Shell Style	Shell Material / Finish	Shell Size/Insert	Contact Type	Shell Key Position
804-006 Hermetic Receptacles with Printed Circuit Board Contacts or Solder Cup Contacts	 -00 Jam Nut, Front Panel	Z1 Stainless Steel / Passivated	5-3 3 #23 6-1 1 #16 6-4 4 #23 6-7 7 #23 7-1 1 #12 7-10 10 #23 8-13 13 #23 9-4 4 #16 9-19 19 #23 10-26 26 #23 12-2 2 #12 12-37 37 #23 14-55 55 #23 15-85 85 #23	P Pin, Solder Cup C Pin, PC Tail	Omit for Single Master Key A Pos. A (Normal) B Pos. B C Pos. C D Pos. D
	 -07 Jam Nut, Rear Panel	ZL Stainless Steel/ Nickel Plated			

Series 804 Hermetic Receptacles – Rear Panel Jam Nut

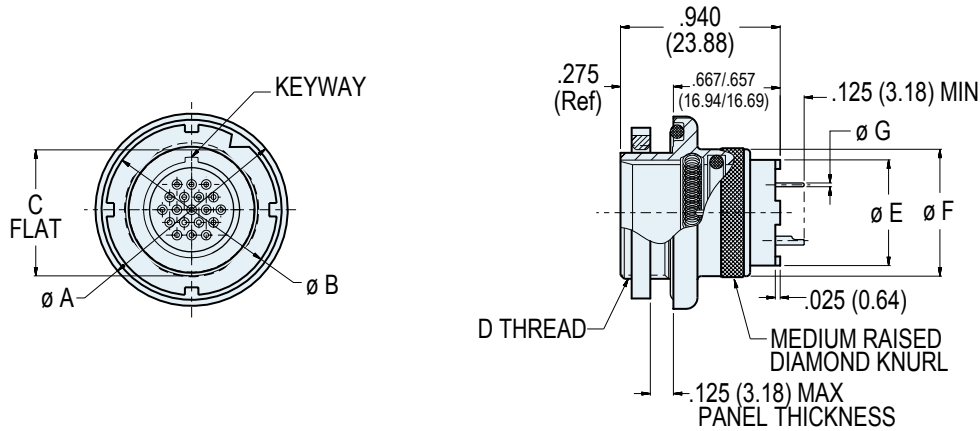

Rear Panel Jam Nut
804-006-07

DIMENSIONS

Shell Size	Ø A		Ø B		C Flat		D Threads	Ø E		Ø F		Ø G Tail Dia.
	In.	mm.	In.	mm.	In.	mm.		In.	mm.	In.	mm.	
5	.790	20.07	.562	14.27	.415	10.54	.4375-32 UN-2A	.244	6.20	.450	11.43	#23
6	.830	21.08	.625	15.87	.467	14.40	.5000-32 UN-2A	.330	8.38	.520	13.21	.018/.022 (0.46/0.56)
7	.910	23.11	.750	19.05	.594	15.09	.6250-28 UN-2A	.432	10.97	.580	14.73	
8	.955	24.26	.750	19.05	.594	15.09	.6250-28 UN-2A	.493	12.52	.603	15.32	#16
9	1.000	25.40	.812	20.62	.655	16.64	.6875-32 UN-2A	.551	14.00	.695	17.65	.060/.064 (1.52/1.63)
10	1.085	27.48	.875	22.22	.721	18.31	.7500-28 UN-2A	.620	15.75	.735	18.67	
12	1.180	29.97	1.000	25.40	.843	21.41	.8750-28 UN-2A	.703	17.86	.880	22.35	#12
14	1.325	33.66	1.125	28.57	.968	24.59	1.0000-28 UN-2A	.863	21.92	1.010	25.65	.092/.096 (2.34/2.44)
15	1.390	35.31	1.188	30.17	1.029	26.14	1.0625-20 UN-2A	.912	23.16	1.060	26.92	

ALTERNATE KEY POSITIONS

Pos.	A°	B°
A	150°	210°
B	75°	210°
C	95°	230°
D	140°	275°

JAM NUT PANEL CUTOUT

Shell Size	A Flat		Ø B	
	In. ±.002	mm. ±0.05	In.	mm.
5	.425	10.80	.448	11.38
6	.477	12.12	.510	12.95
7	.604	15.34	.635	16.13
8	.604	15.34	.635	16.13
9	.665	16.89	.695	17.65
10	.731	18.57	.760	19.30
12	.853	21.67	.885	22.48
14	.978	24.84	1.010	25.65
15	1.039	26.39	1.070	27.18

Series 804 Hermetic Receptacles – Front Panel Jam Nut

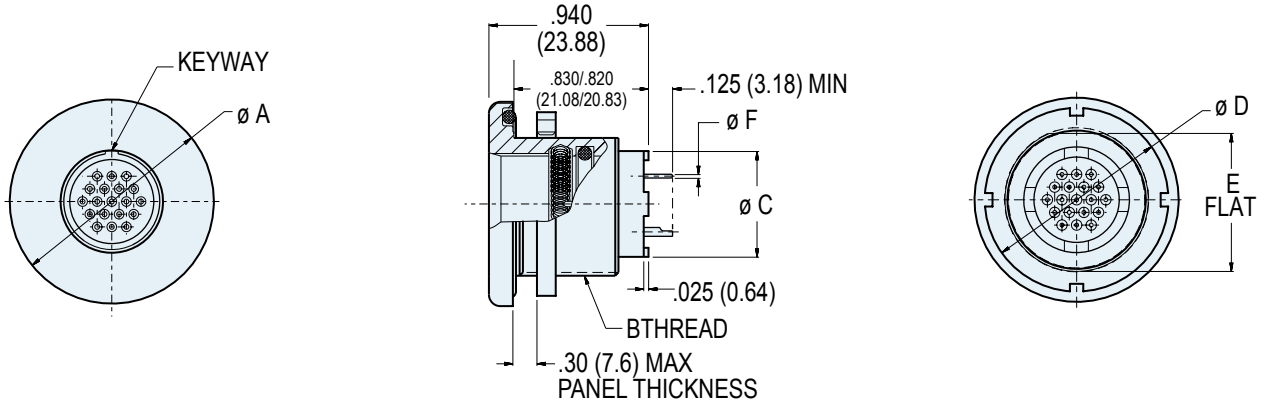

Front Panel Jam Nut
804-006-07

DIMENSIONS									
Shell Size	Ø A		B Threads	Ø C		Ø E		E Flat	
	In.	mm.		In.	mm.	In.	mm.	In.	mm.
5	.830	21.08	.5000-32 UN-2A	.244	6.20	.625	15.87	.470	11.94
6	.885	22.48	.6250-28 UN-2A	.330	8.38	.688	17.47	.530	13.46
7	.995	25.27	.6875-32 UN-2A	.432	10.97	.812	20.62	.663	16.84
8	.995	25.27	.6875-32 UN-2A	.493	12.52	.812	20.62	.663	16.84
9	1.075	27.31	.7500-28 UN-2A	.551	14.00	.875	22.22	.720	18.29
10	1.140	28.95	.8750-28 UN-2A	.620	15.75	.938	23.82	.788	20.02
12	1.340	34.04	1.0000-28 UN-2A	.703	17.86	1.125	28.57	.970	24.64
14	1.390	35.31	1.0625-20 UN-2A	.863	21.92	1.188	30.18	1.020	25.91
15	1.450	36.83	1.1250-28 UN-2A	.912	23.16	1.250	31.75	1.093	27.76

ALTERNATE KEY POSITIONS

Pos.	A°	B°
A	150°	210°
B	75°	210°
C	95°	230°
D	140°	275°

JAM NUT PANEL CUTOUT

Shell Size	A Flat		Ø B	
	In. ± .002	mm. ± 0.05	In.	mm.
5	.480	12.19	.510	12.95
6	.540	13.72	.575	14.61
7	.674	17.12	.698	17.73
8	.674	17.12	.698	17.73
9	.730	18.54	.760	19.30
10	.799	20.29	.822	20.88
12	.980	24.89	1.010	25.65
14	1.030	26.16	1.075	27.31
15	1.013	25.73	1.135	28.83