

10-101949 and 10-101949-S Square Flange Panel Mount Receptacle Sealing Gaskets

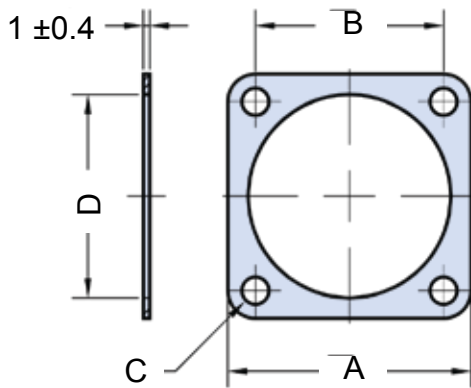

Example: 10-101949
(Neoprene)

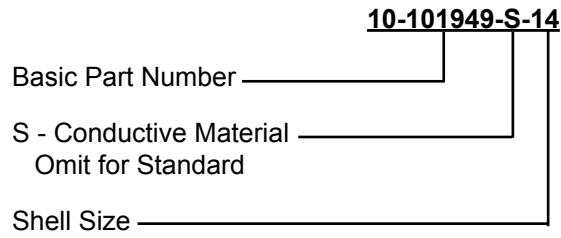
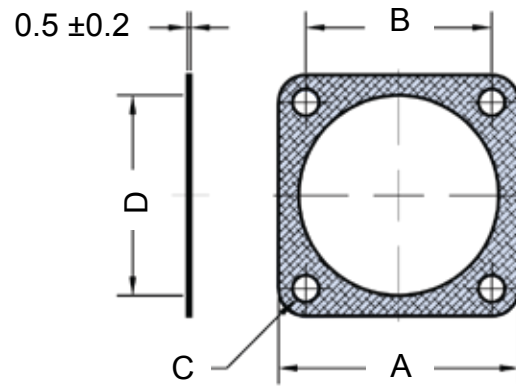

Example: 10-101949-S
(Conductive)

TABLE I

Commital P/N	Shell size	A ±0.5	B ±1	C ±0.7	D ±0.5
10-101949- 8	8	20.6	15.10	3.3	12.7
10-101949-10	10	23.8	18.25	3.3	15.9
10-101949-12	12	26.2	20.60	3.3	19.1
10-101949-14	14	28.6	23.00	3.3	22.3
10-101949-16	16	31.0	24.60	3.3	25.5
10-101949-18	18	33.3	27.00	3.3	28.6
10-101949-20	20	36.5	29.35	3.3	31.8
10-101949-22	22	39.7	31.75	3.3	35.0
10-101949-24	24	42.9	34.90	4.0	38.2