



Features

- Duplex LC Single Mode Transceiver
- Small Form Factor Multi-sourced 2 x 5 Pin Package
- Long reach SONET OC-3 / SDH STM-1 LR1 Compliant
- Single +3.3V Power Supply
- LVPECL Differential Inputs and Outputs
- Class 1 Laser International Safety Standard IEC 825 Compliant
- Solderability to MIL-STD-883, Method 2003
- Flammability to UL94V0
- Humidity RH 5-85% (5-95% short term) to IEC 68-2-3
- Complies with Bellcore GR-468-CORE
- Uncooled laser diode with MQW structure
- ATM 155Mb/s Links
- RoHS compliance available

Table 1 – Absolute Maximum Rating

Parameter	Symbol	Min.	Typical	Max.	Notes
Power Supply Voltage	V _{CC}	0	3.6	V	
Output Current	I _{out}	0	30	mA	
Soldering Temperature	-	-	260	°C	10 seconds on leads only
Storage Temperature	T _{stg}	-40	85	°C	

Table 2 – Recommended Operating Condition

Parameter	Symbol	Min.	Typical	Max.	Notes
Power Supply Voltage	V _{CC}	3.1	3.3	3.5	V
Operating Temperature (Case)1	T _{opr}	-40	-	85	°C
Data Rate	-	-	155	-	Mbps

Note 1 : Please refer to ordering information

Table 3 – Transmitter Specifications (Optical)

Parameter	Symbol	Min.	Typical	Max.	Unit	Notes
Optical Transmit Power	P _o	-4.5	-	0	dBm	Output power is coupled into a 9/125μm single mode fiber.
Output center Wavelength	λ	1280	1310	1335	nm	
Output Spectrum Width	Δλ	-	-	1	nm	-20 dB width
Side Mode Suppression Ratio	Sr	30	35	-	dBm	
Extinction Ratio	ER	10	-	-	dB	
Output Eye	Compliant with ITU recommendation G.957					
Optical Rise Time	t _r	-	-	2	ns	10% to 90% Values
Optical Fall Time	t _f	-	-	2	ns	10% to 90% Values
Relative Intensity Noise	RIN	-	-	-116	dB/Hz	
Total Jitter	TJ	-	-	1.2	ns	Measured with 2 ²³ -1 PRBS

Table 4 – Transmitter Specifications (Electrical)

Parameter	Symbol	Min.	Typical	Max.	Unit	Notes
Power Supply Current	I _{CC}	-	-	180	mA	Maximum current is specified at V _{CC} = Maximum @ maximum temperature
Transmit Enable Voltage	V _{EN}	0	-	0.8	V	
Transmit Disable Voltage	V _D	2.0	-	V _{CC}	V	
Data Input Current-Low	I _{IL}	-200	-	-	μA	
Data Input Current-High	I _{IH}	-	-	200	μA	
Data Input Voltage-Low	V _{IL} -V _{CC}	-2.0	-	-1.58	V	These inputs are compatible with 10K, 10KH and 100K ECL and PECL inputs
Data Input Voltage-High	V _{IH} -V _{CC}	-1.1	-	-0.74	V	

Table 5 – Receiver Specifications (Optical)

Parameter	Symbol	Min.	Typical	Max.	Unit	Notes
Sensitivity	-	-	-	-35	dBm	Measured with 2 ²³ -1 PRBS with 72 ones and 72 zeros. (ITU-T recommendation G.958)
Maximum Input Power	Pin	0	-	-	dBm	
Signal Detect-Asserted	Pa	-	-	-35	dBm	Measured on transition: low to high
Signal Detect-Deasserted	Pd	-48	-	-	dBm	Measured on transition: high to low
Signal Detect-Hysteresis		0.5	-	4.0	dB	
Wavelength of Operation		1100	-	1600	nm	

Table 6 – Receiver Specifications (Electrical)

Parameter	Symbol	Min.	Typical	Max.	Unit	Notes
Power Supply Current	I _{CC}	-	-	100	mA	The current excludes the output load current
Data Output Voltage-Low	V _{OL} -V _{CC}	-1.98	-	-1.71	V	These outputs are compatible with 10K, 10KH and 100K ECL and LVPECL outputs
Data Output Voltage-High	V _{OH} -V _{CC}	-1.1	-	-0.91	V	
Signal Detect Output Voltage-Low	V _{SDL} -V _{CC}	-1.98	-	-1.71	V	C-13-155-FDFB-SLC8A-G5 LVPECL
Signal Detect Output Voltage-High	V _{SDH} -V _{CC}	-1.1	-	-0.91	V	
Signal Detect Output Voltage-Low	V _{SDL}	0	-	0.5	V	C-13-155C-FDFB-SLC8A-G5 LVTTTL
Signal Detect Output Voltage-High	V _{SDH}	2	-	V _{CC}	V	

Connection Diagram

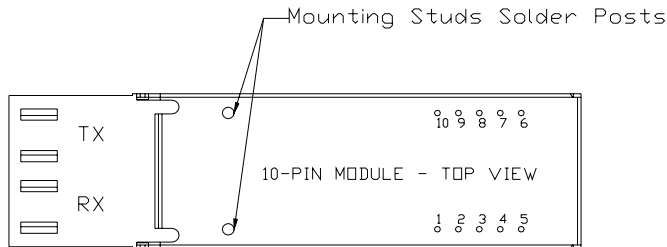

Pin	Symbol	Notes
1	RxGND	Directly connect this pin to the receiver ground plane
2	TxVcc	+3.3 V dc power for the receiver section
3	SD	Active high on this indicates a received optical signal(LVPECL/LVTTL)
4	RD-	Receiver Data Out Bar (LVPECL)
5	RD+	Receiver Dat Out (LVPECL)
6	TxVcc	+3.3 V dc power for the transmitter section
7	TxGND	Directly connect this pin to the transmitter ground plane
8	TxDIS	Transmitter disable (LVTTL)
9	TD+	Transmitter Data In (LVPECL)
10	TD-	Transmitter Data In Bar (LVPECL)
Attaching Posts		The attaching posts are at case potential and may be connected to chassis ground. They are isolated from circuit ground.

Recommended Interface Circuit

C-13-155-FDFB-SLC8A-G5

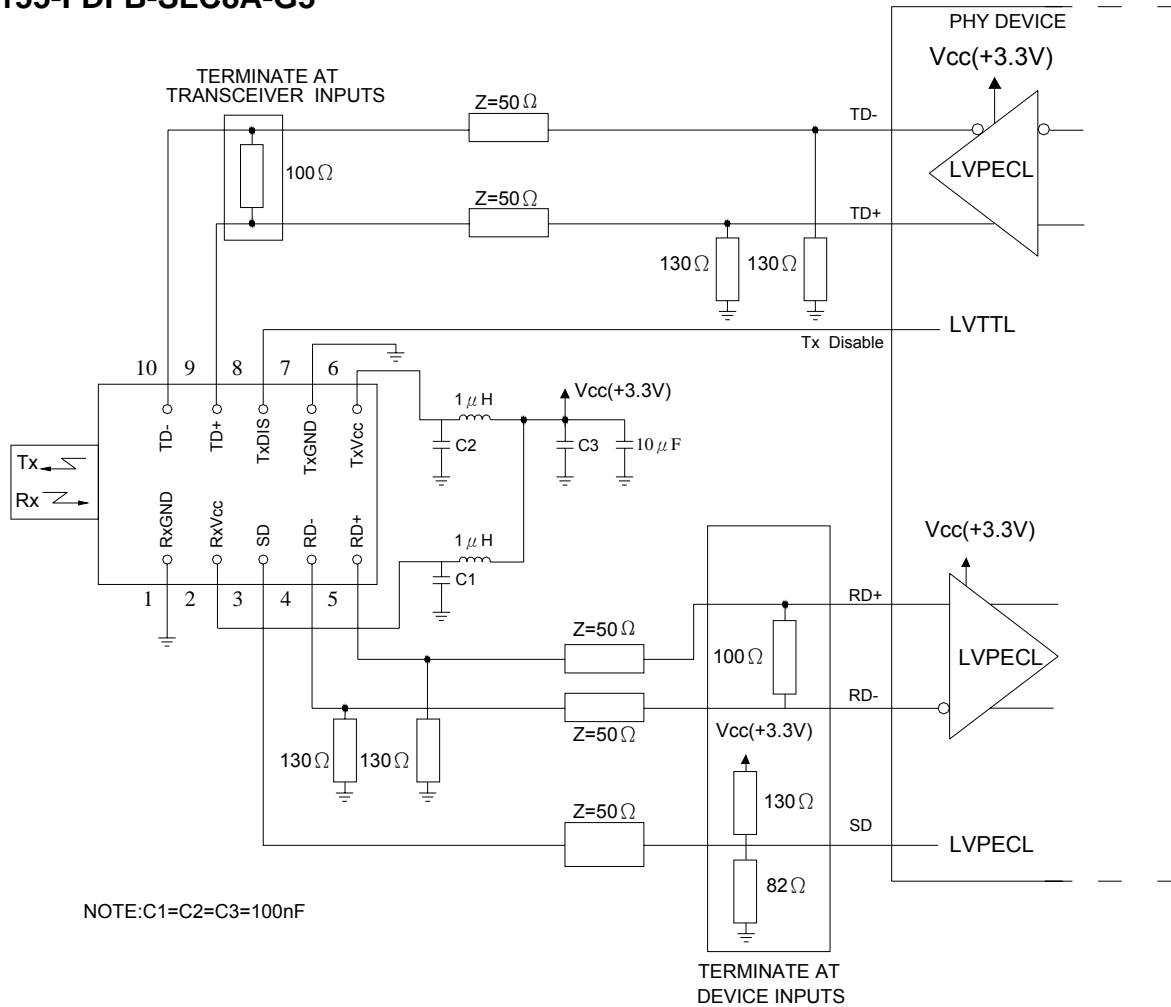

C-13-155C-FDFB-SLC8A-G5

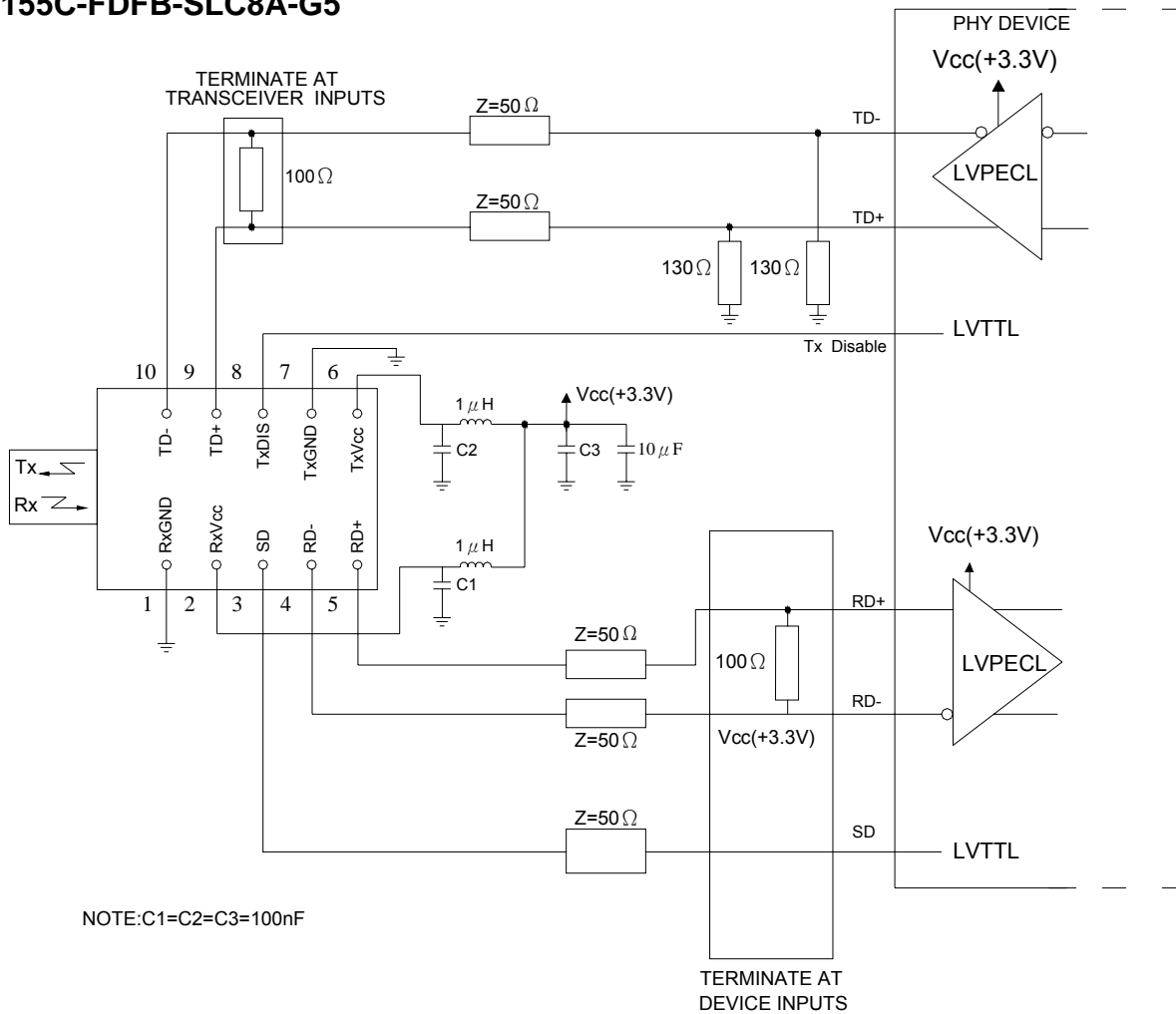

The split-loaded terminations for ECL signals need to be located at the input of devices receiving those ECL signals.

The power supply filtering is required for good EMI performance. Use short tracks from the inductor L1/L2 to the module Rx Vcc.

A GND plane under the module is required for good EMI and sensitivity performance.

Printed Circuit Board Layout Consideration

A fiber-optic receiver employs a very high gain, wide bandwidth transimpedance amplifier. This amplifier detects and amplifies signals that are only tens of nA in amplitude when the receiver is operating near its limit. Any unwanted signal current that couples into the receiver circuitry causes a decrease in the receiver's sensitivity and can also degrade the performance of the receiver's signal detect (SD) circuit. To minimize the coupling of unwanted noise into the receiver, careful attention must be given to the printed circuit board.

At a minimum, a double-sided printed circuit board (PCB) with a large component side ground plane beneath the transceiver must be used. In applications that include many other high speed devices, a multi-layer PCB is highly recommended. This permits the placement of power and ground on separate layers, which allows them to be isolated from the signal lines. Multilayer construction also permits the routing of signal traces away from high level, high speed signal lines. To minimize the possibility of coupling noise into the receiver section, high level, high speed signals such as transmitter inputs and clock lines should be routed as far away as possible from the receiver pins.

Noise that couples into the receiver through the power supply pins can also degrade performance. It is recommended that a pi filter be used in both transmitter and receiver power supplies.

EMI and ESD Consideration

Source Photonics' transceivers offer a metalized plastic case and a special chassis grounding clip. As shown in the drawing, this clip connects the module case to chassis ground then installs flush through the panel cutout. This way, the grounding clip brushes the edge of the cutout in order to make a proper contact. The use of a grounding clip also provides increased electrostatic protection and helps reduce radiated emission from the module or the host circuit board through the chassis faceplate. The attaching posts are at case potential and may be connected to chassis ground. They should not be connected to circuit ground.

Plastic optical subassemblies are used to further reduce the possibility of radiated emission by eliminating the metal from the transmitter and receiver diode housings, which extend into connector space. By providing a non-metal receptacle for the optical cable ferrule, the gigabit speed RF electrical signal is isolated from the connector area thus preventing radiated energy leakage from these surfaces to the outside of the panel.

Recommended Board Layout Hole Pattern

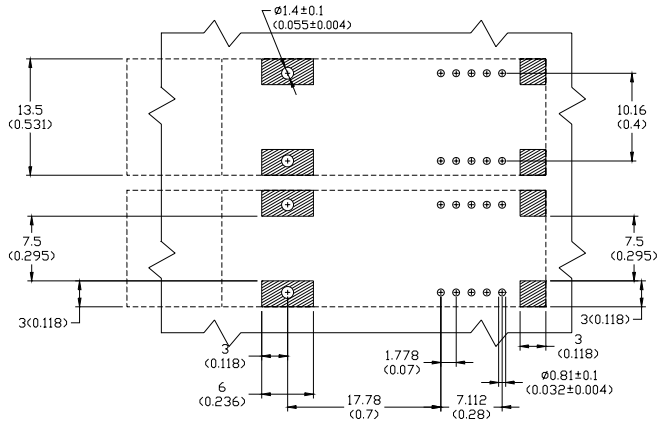

DIMENSION IN MILLIMETER (INCHES)

NOTES:

1. THIS FIGURE DESCRIBE THE RECOMMAND CIRCUIT BOARD LAYOUT FOR THE SFF TRANSCEIVER.
2. THE HATCHED AREAS ARE KEEP-OUT AREAS RESERVED FOR HOUSING STANDOFF. NO METAL TRACES OR GROUND CONNECTION IN KEEP-OUT AREAS.
3. THE MOUNTING STUDS SHOULD BE SOLDERED TO CHASSIS GROUND FOR MECHANICAL INTEGRITY.

Recommended Board Layout Hole Pattern

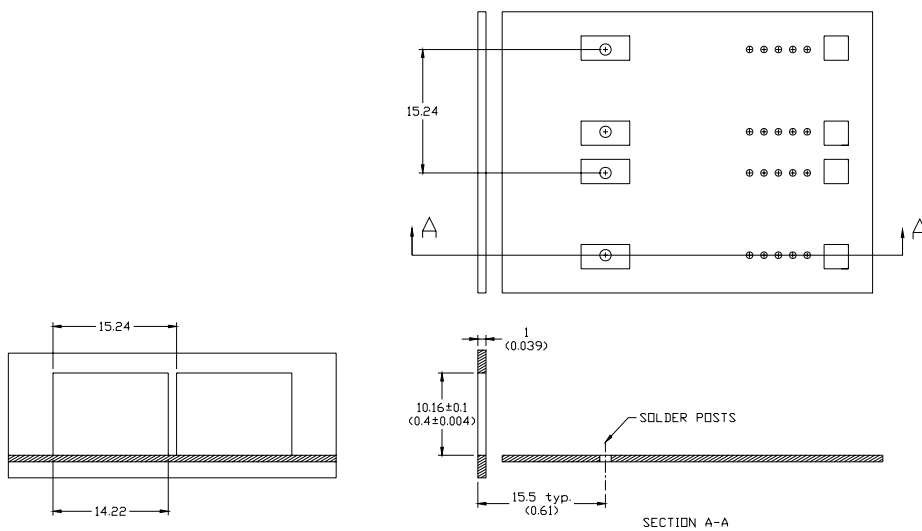

DIMENSION IN MILLIMETER (INCHES)

Package Diagram

Units:mm(inch)

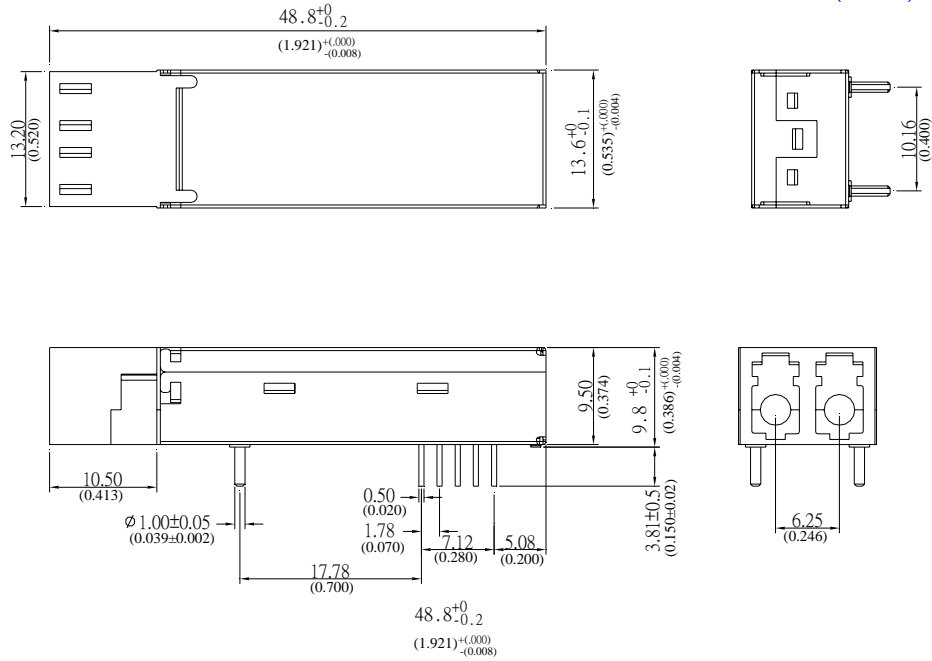

Ordering Information

Table 7 – Available options

Part No.
C-13-155-FDFB-SLC8A-G5
C-13-155C-FDFB-SLC8A-G5

Part Numbering Definition:

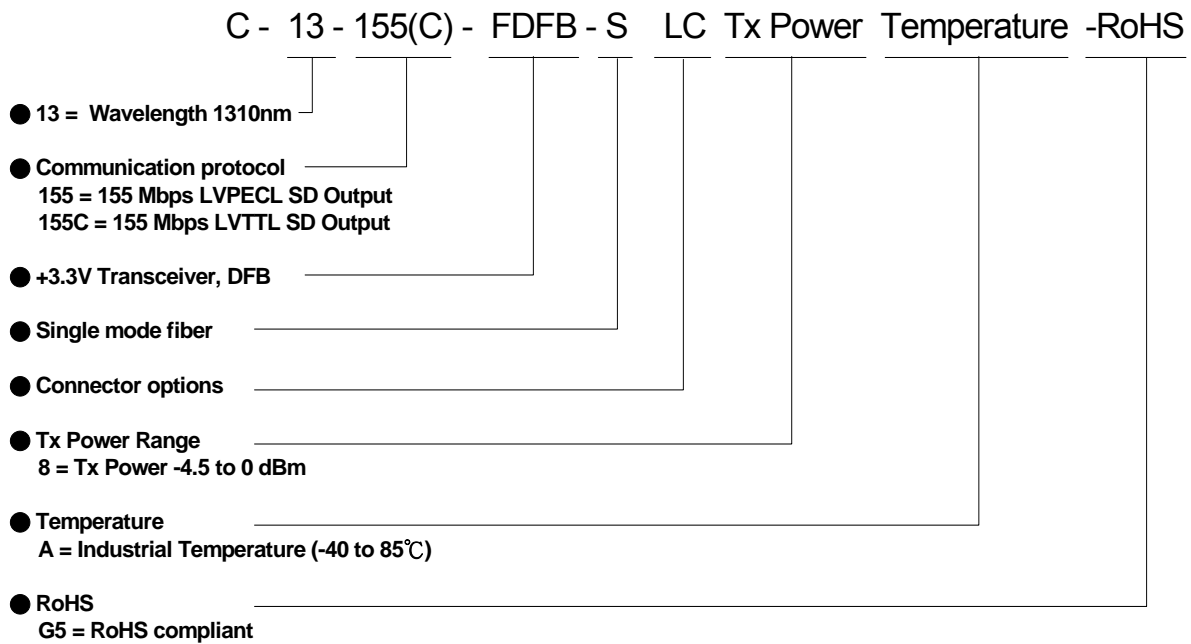

Warnings

Handling Precautions: This device is susceptible to damage as a result of electrostatic discharge (ESD). A static free environment is highly recommended. Follow guidelines according to proper ESD procedures.

Laser Safety: Radiation emitted by laser devices can be dangerous to human eyes. Avoid eye exposure to direct or indirect radiation.

Legal Notice

IMPORTANT NOTICE!

All information contained in this document is subject to change without notice, at Source Photonics' sole and absolute discretion. Source Photonics warrants performance of its products to current specifications only in accordance with the company's standard one-year warranty; however, specifications designated as "preliminary" are given to describe components only, and Source Photonics expressly disclaims any and all warranties for said products, including express, implied, and statutory warranties, warranties of merchantability, fitness for a particular purpose, and non-infringement of proprietary rights. Please refer to the company's Terms and Conditions of Sale for further warranty information.

Source Photonics assumes no liability for applications assistance, customer product design, software performance, or infringement of patents, services, or intellectual property described herein. No license, either express or implied, is granted under any patent right, copyright, or intellectual property right, and Source Photonics makes no representations or warranties that the product(s) described herein are free from patent, copyright, or intellectual property rights. Products described in this document are NOT intended for use in implantation or other life support applications where malfunction may result in injury or death to persons. Source Photonics customers using or selling products for use in such applications do so at their own risk and agree to fully defend and indemnify Source Photonics for any damages resulting from such use or sale.

THE INFORMATION CONTAINED IN THIS DOCUMENT IS PROVIDED ON AN "AS IS" BASIS. Customer agrees that Source Photonics is not liable for any actual, consequential, exemplary, or other damages arising directly or indirectly from any use of the information contained in this document. Customer must contact Source Photonics to obtain the latest version of this publication to verify, before placing any order, that the information contained herein is current.

Contact

U.S.A. Headquarters

20550 Nordhoff Street
Chatsworth, CA 91311
USA

Tel: +1-818-773-9044

Fax: +1-818-773-0261

sales@sourcephotonics.com

China

Building #2&5, West Export Processing Zone
No. 8 Kexin Road, Hi-Tech Zone
Chengdu, 611731, China

Tel: +86-28-8795-8788

Fax: +86-28-8795-8789

sales@sourcephotonics.com.cn

Taiwan

9F, No 81, Shui Lee Rd.
Hsinchu, 300, Taiwan
R.O.C.

Tel: +886-3-5169222

Fax: +886-3-5169213

sales@sourcephotonics.com.tw

© Copyright Source Photonics, Inc. 2007~2008

All rights reserved