

DATA SHEET

E18/4/10

Planar E cores and accessories

Supersedes data of September 2004

2008 Sep 01



FERROXCUBE
A YAGEO COMPANY

CORES

Effective core parameters of a set of E cores

SYMBOL	PARAMETER	VALUE	UNIT
$\Sigma(l/A)$	core factor (C1)	0.616	mm ⁻¹
V_e	effective volume	960	mm ³
l_e	effective length	24.3	mm
A_e	effective area	39.3	mm ²
A_{min}	minimum area	39.3	mm ²
m	mass of core half	≈ 2.4	g

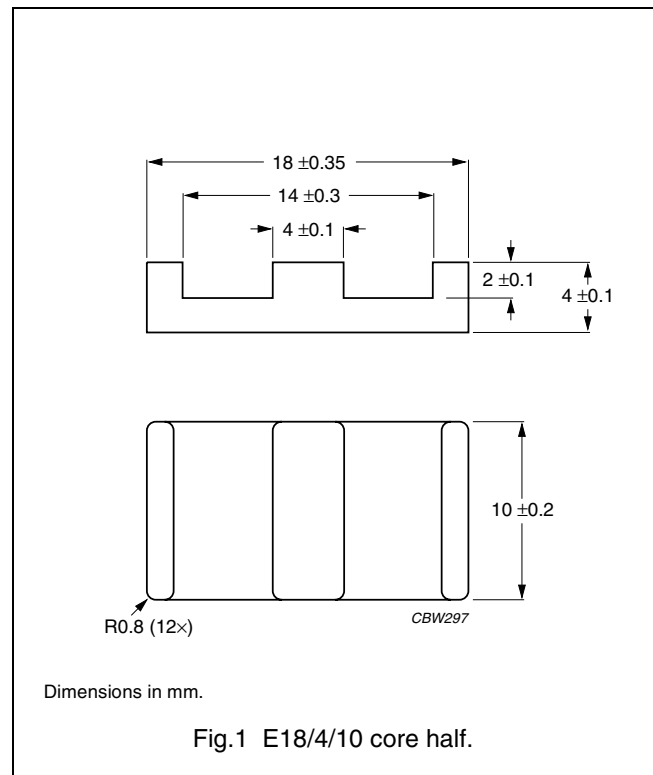

Effective core parameters of an E/PLT combination

SYMBOL	PARAMETER	VALUE	UNIT
$\Sigma(l/A)$	core factor (C1)	0.514	mm ⁻¹
V_e	effective volume	800	mm ³
l_e	effective length	20.3	mm
A_e	effective area	39.5	mm ²
A_{min}	minimum area	39.5	mm ²
m	mass of plate	≈ 1.7	g

Ordering information for plates

GRADE	TYPE NUMBER
3C90	PLT18/10/2-3C90
3C92 <small>des</small>	PLT18/10/2-3C92
3C93 <small>des</small>	PLT18/10/2-3C93
3C94	PLT18/10/2-3C94
3C95 <small>des</small>	PLT18/10/2-3C95
3C96 <small>des</small>	PLT18/10/2-3C96
3F3	PLT18/10/2-3F3
3F35 <small>des</small>	PLT18/10/2-3F35
3F4 <small>des</small>	PLT18/10/2-3F4
3F45 <small>prot</small>	PLT18/10/2-3F45
3E6	PLT18/10/2-3E6

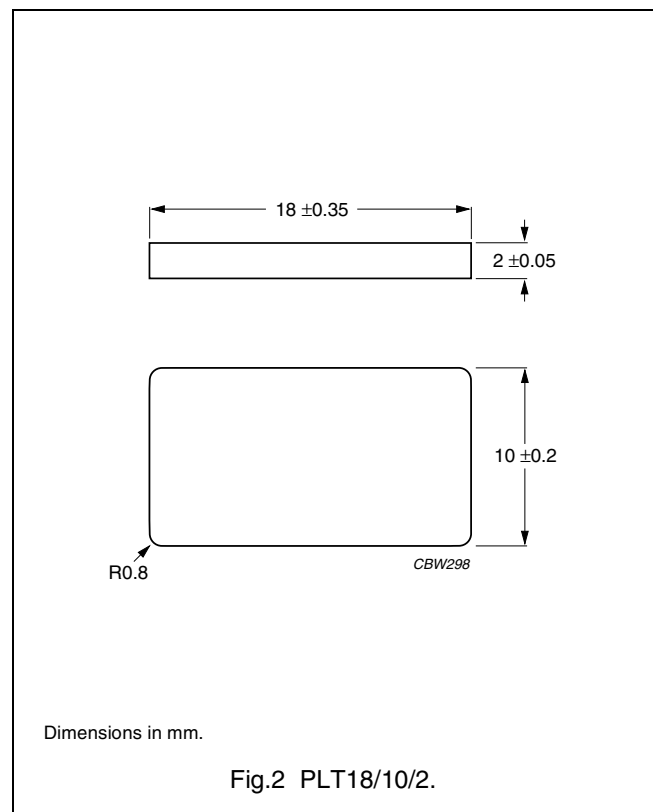

Planar E cores and accessories

E18/4/10

Core halves for use in combination with a non-gapped E core

A_L measured in combination with a non-gapped core half, clamping force for A_L measurements, 20 ± 10 N, using a PCB coil containing 4 layers of 8 tracks each, total height 1.6 mm.

GRADE	A_L (nH)	μ_e	AIR GAP (μm)	TYPE NUMBER
3C90	100 $\pm 3\%$	≈ 49	≈ 800	E18/4/10-3C90-A100-E
	160 $\pm 3\%$	≈ 78	≈ 420	E18/4/10-3C90-A160-E
	250 $\pm 5\%$	≈ 123	≈ 220	E18/4/10-3C90-A250-E
	315 $\pm 8\%$	≈ 154	≈ 170	E18/4/10-3C90-A315-E
	3200 $\pm 25\%$	≈ 1560	≈ 0	E18/4/10-3C90
3C92 des	2330 $\pm 25\%$	≈ 1140	≈ 0	E18/4/10-3C92
3C93 des	2700 $\pm 25\%$	≈ 1320	≈ 0	E18/4/10-3C93
3C94	100 $\pm 3\%$	≈ 49	≈ 800	E18/4/10-3C94-A100-E
	160 $\pm 3\%$	≈ 78	≈ 420	E18/4/10-3C94-A160-E
	250 $\pm 5\%$	≈ 123	≈ 220	E18/4/10-3C94-A250-E
	315 $\pm 8\%$	≈ 154	≈ 170	E18/4/10-3C94-A315-E
	3200 $\pm 25\%$	≈ 1560	≈ 0	E18/4/10-3C94
3C95 des	3800 $\pm 25\%$	≈ 1870	≈ 0	E18/4/10-3C95
3C96 des	2900 $\pm 25\%$	≈ 1410	≈ 0	E18/4/10-3C96
3F3	100 $\pm 3\%$	≈ 49	≈ 800	E18/4/10-3F3-A100-E
	160 $\pm 3\%$	≈ 78	≈ 420	E18/4/10-3F3-A160-E
	250 $\pm 5\%$	≈ 123	≈ 220	E18/4/10-3F3-A250-E
	315 $\pm 8\%$	≈ 154	≈ 170	E18/4/10-3F3-A315-E
	2700 $\pm 25\%$	≈ 1320	≈ 0	E18/4/10-3F3
3F35 des	2200 $\pm 25\%$	≈ 1070	≈ 0	E18/4/10-3F35
3F4 des	100 $\pm 3\%$	≈ 49	≈ 800	E18/4/10-3F4-A100-E
	160 $\pm 3\%$	≈ 78	≈ 420	E18/4/10-3F4-A160-E
	250 $\pm 5\%$	≈ 123	≈ 220	E18/4/10-3F4-A250-E
	315 $\pm 8\%$	≈ 154	≈ 170	E18/4/10-3F4-A315-E
	1550 $\pm 25\%$	≈ 760	≈ 0	E18/4/10-3F4
3F45 prot	1550 $\pm 25\%$	≈ 760	≈ 0	E18/4/10-3F45
3E6	13500 $+40/-30\%$	≈ 6600	≈ 0	E18/4/10-3E6

Planar E cores and accessories

E18/4/10

Core halves for use in combination with a plate (PLT)

A_L measured in combination with a plate (PLT), clamping force for A_L measurements, 20 ± 10 N, using a PCB coil containing 4 layers of 8 tracks each, total height 1.6 mm.

GRADE	A_L^0 (nH)	μ_e	AIR GAP (μm)	TYPE NUMBER
3C90	100 $\pm 3\%$	≈ 41	≈ 870	E18/4/10-3C90-A100-P
	160 $\pm 3\%$	≈ 65	≈ 470	E18/4/10-3C90-A160-P
	250 $\pm 5\%$	≈ 102	≈ 240	E18/4/10-3C90-A250-P
	315 $\pm 8\%$	≈ 129	≈ 170	E18/4/10-3C90-A315-P
	3680 $\pm 25\%$	≈ 1500	≈ 0	E18/4/10-3C90
3C92 des	2690 $\pm 25\%$	≈ 1100	≈ 0	E18/4/10-3C92
3C93 des	3100 $\pm 25\%$	≈ 1270	≈ 0	E18/4/10-3C93
3C94	100 $\pm 3\%$	≈ 41	≈ 870	E18/4/10-3C94-A100-P
	160 $\pm 3\%$	≈ 65	≈ 470	E18/4/10-3C94-A160-P
	250 $\pm 5\%$	≈ 102	≈ 240	E18/4/10-3C94-A250-P
	315 $\pm 8\%$	≈ 129	≈ 170	E18/4/10-C94-A315-P
	3680 $\pm 25\%$	≈ 1500	≈ 0	E18/4/10-3C94
3C95 des	4340 $\pm 25\%$	≈ 1780	≈ 0	E18/4/10-3C95
3C96 des	3250 $\pm 25\%$	≈ 1320	≈ 0	E18/4/10-3C96
3F3	100 $\pm 3\%$	≈ 41	≈ 870	E18/4/10-3F3-A100-P
	160 $\pm 3\%$	≈ 65	≈ 470	E18/4/10-3F3-A160-P
	250 $\pm 5\%$	≈ 102	≈ 240	E18/4/10-3F3-A250-P
	315 $\pm 8\%$	≈ 129	≈ 170	E18/4/10-3F3-A315-P
	3100 $\pm 25\%$	≈ 1270	≈ 0	E18/4/10-3F3
3F35 des	2500 $\pm 25\%$	≈ 1020	≈ 0	E18/4/10-3F35
3F4 des	100 $\pm 3\%$	≈ 41	≈ 870	E18/4/10-3F4-A100-P
	160 $\pm 3\%$	≈ 65	≈ 470	E18/4/10-3F4-A160-P
	250 $\pm 5\%$	≈ 102	≈ 240	E18/4/10-3F4-A250-P
	315 $\pm 8\%$	≈ 129	≈ 170	E18/4/10-3F4-A315-P
	1800 $\pm 25\%$	≈ 740	≈ 0	E18/4/10-3F4
3F45 prot	1800 $\pm 25\%$	≈ 740	≈ 0	E18/4/10-3F45
3E6	15500 +40/-30%	≈ 6400	≈ 0	E18/4/10-3E6

Planar E cores and accessories

E18/4/10

Properties of core sets under power conditions

GRADE	B (mT) at	CORE LOSS (W) at				
	H = 250 A/m; f = 10 kHz; T = 100 °C	f = 100 kHz; \hat{B} = 100 mT; T = 100 °C	f = 100 kHz; \hat{B} = 200 mT; T = 25 °C	f = 100 kHz; \hat{B} = 200 mT; T = 100 °C	f = 400 kHz; \hat{B} = 50 mT; T = 100 °C	f = 500 kHz; \hat{B} = 50 mT; T = 100 °C
E+E18-3C90	≥320	≤ 0.105	–	–	–	–
E+PLT18-3C90	≥320	≤ 0.095	–	–	–	–
E+E18-3C92	≥370	≤ 0.085	–	≤ 0.6	–	–
E+PLT18-3C92	≥370	≤ 0.075	–	≤ 0.5	–	–
E+E18-3C93	≥320	≤ 0.085 ⁽¹⁾	–	≤ 0.6 ⁽¹⁾	–	–
E+PLT18-3C93	≥320	≤ 0.075 ⁽¹⁾	–	≤ 0.5 ⁽¹⁾	–	–
E+E18-3C94	≥320	≤ 0.085	–	≤ 0.6	–	–
E+PLT18-3C94	≥320	≤ 0.075	–	≤ 0.5	–	–
E+E18-3C95	≥320	–	≤ 0.53	≤ 0.5	–	–
E+PLT18-3C95	≥320	–	≤ 0.44	≤ 0.42	–	–
E+E18-3C96	≥320	≤ 0.065	–	≤ 0.45	≤ 0.18	≤ 0.35
E+PLT18-3C96	≥320	≤ 0.06	–	≤ 0.4	≤ 0.15	≤ 0.3
E+E18-3F3	≥300	≤ 0.11	–	–	≤ 0.19	–
E+PLT18-3F3	≥300	≤ 0.09	–	–	≤ 0.16	–
E+E18-3F35	≥300	–	–	–	≤ 0.09	≤ 0.13
E+PLT18-3F35	≥300	–	–	–	≤ 0.08	≤ 0.12

1. Measured at 140 °C.

Properties of core sets under power conditions (continued)

GRADE	B (mT) at	CORE LOSS (W) at			
	H = 250 A/m; f = 10 kHz; T = 100 °C	f = 500 kHz; \hat{B} = 100 mT; T = 100 °C	f = 1 MHz; \hat{B} = 30 mT; T = 100 °C	f = 1 MHz; \hat{B} = 50 mT; T = 100 °C	f = 3 MHz; \hat{B} = 10 mT; T = 100 °C
E+E18-3F35	≥300	≤ 1.0	–	–	–
E+PLT18-3F35	≥300	≤ 0.9	–	–	–
E+E18-3F4	≥250	–	≤ 0.3	–	≤ 0.45
E+PLT18-3F4	≥250	–	≤ 0.24	–	≤ 0.39
E+E18-3F45	≥250	–	≤ 0.22	≤ 0.82	≤ 0.38
E+PLT18-3F45	≥250	–	≤ 0.18	≤ 0.67	≤ 0.32

MOUNTING INFORMATION

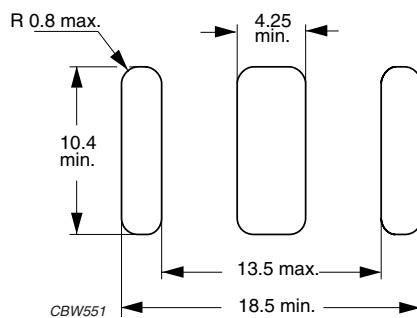

Fig.3 Recommended PCB cut-out for glued planar E18/4/10 cores.

BLISTER TAPE AND REEL DIMENSIONS prot

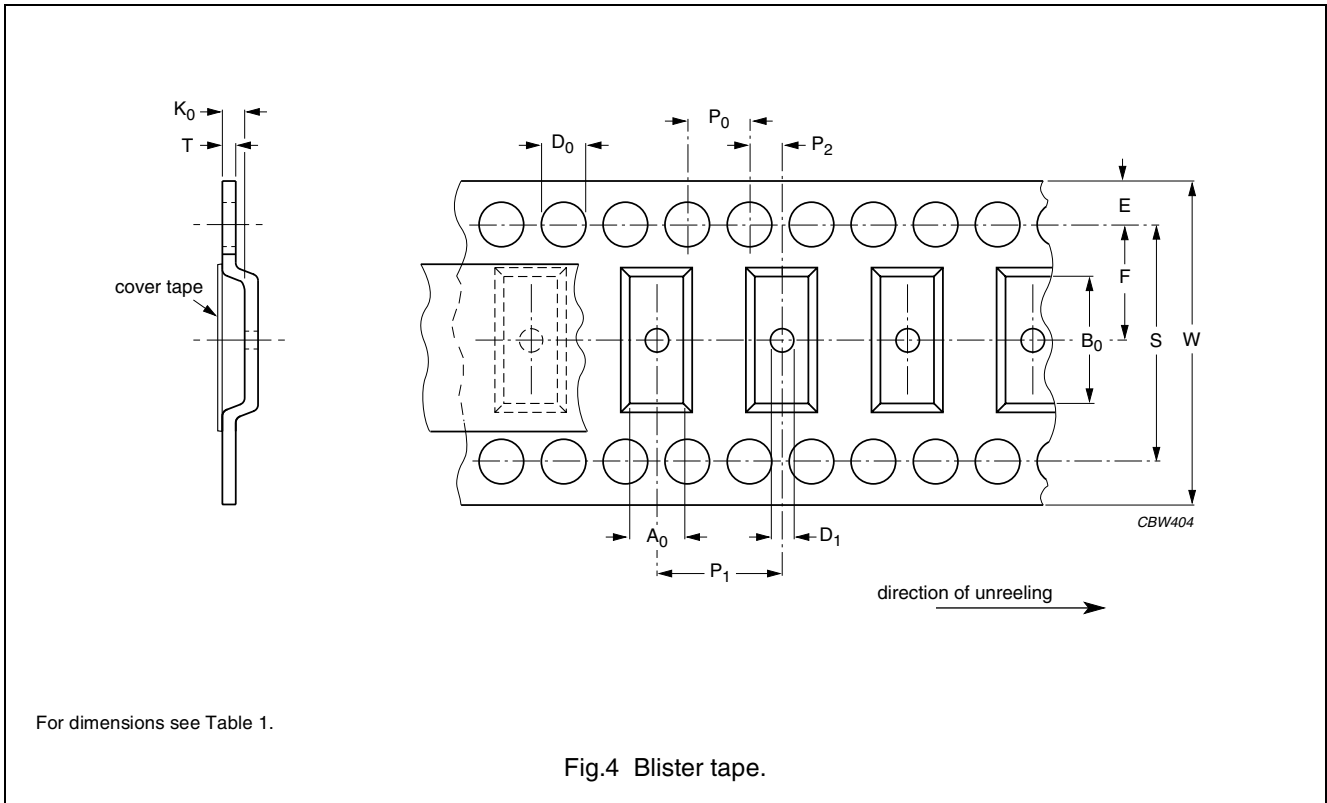

Table 1 Physical dimensions of blister tape; see Fig.4

SIZE	DIMENSIONS (mm)
A_0	10.5 ± 0.2
B_0	18.7 ± 0.2
K_0	4.5 ± 0.2
T	0.3 ± 0.05
W	32.0 ± 0.3
E	1.75 ± 0.1
F	14.2 ± 0.1
D_0	1.5 ± 0.1
D_1	≥ 2.0
P_0	4.0 ± 0.1
P_1	16.0 ± 0.1
P_2	2.0 ± 0.1
S	28.4 ± 0.1

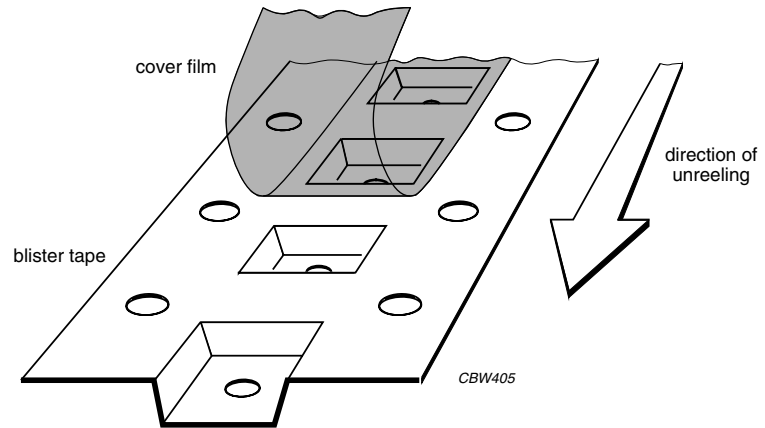
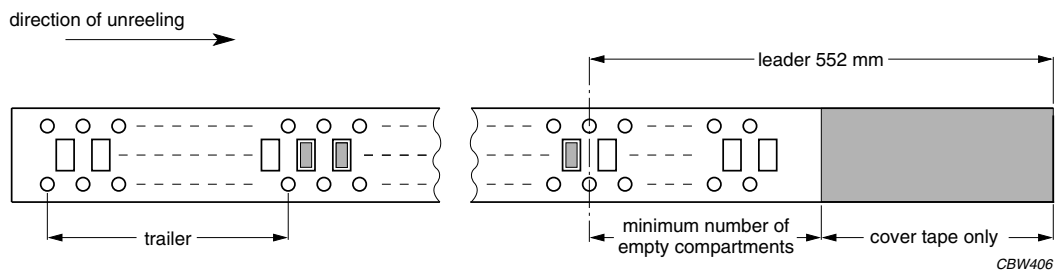

Fig.5 Construction of blister tape.



Leader: length of leader tape is 552 mm minimum covered with cover tape.
Trailer: 160 mm minimum (secured with tape).
Storage temperature range for tape: -25 to +45 °C.

Fig.6 Leader/trailer tape.

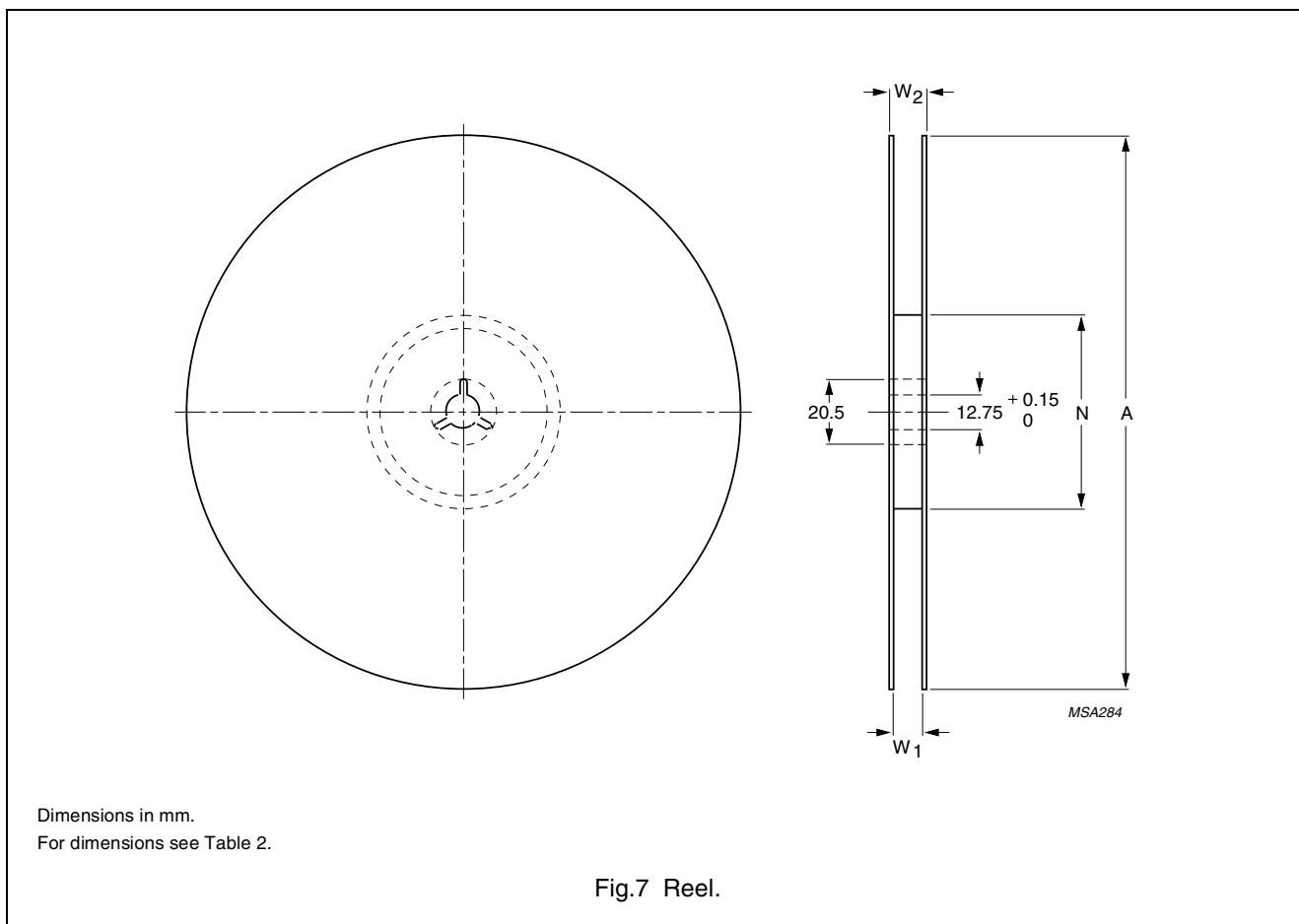

Table 2 Reel dimensions; see Fig.7

SIZE	DIMENSIONS (mm)			
	A	N	W ₁	W ₂
32	330	100 ±5	32.4	≤36.4

Planar E cores and accessories

E18/4/10



DATA SHEET STATUS DEFINITIONS

DATA SHEET STATUS	PRODUCT STATUS	DEFINITIONS
Preliminary specification	Development	This data sheet contains preliminary data. Ferroxcube reserves the right to make changes at any time without notice in order to improve design and supply the best possible product.
Product specification	Production	This data sheet contains final specifications. Ferroxcube reserves the right to make changes at any time without notice in order to improve design and supply the best possible product.

DISCLAIMER

Life support applications — These products are not designed for use in life support appliances, devices, or systems where malfunction of these products can reasonably be expected to result in personal injury. Ferroxcube customers using or selling these products for use in such applications do so at their own risk and agree to fully indemnify Ferroxcube for any damages resulting from such application.

PRODUCT STATUS DEFINITIONS

STATUS	INDICATION	DEFINITION
Prototype		These are products that have been made as development samples for the purposes of technical evaluation only. The data for these types is provisional and is subject to change.
Design-in		These products are recommended for new designs.
Preferred		These products are recommended for use in current designs and are available via our sales channels.
Support		These products are not recommended for new designs and may not be available through all of our sales channels. Customers are advised to check for availability.