

- Designed to meet Supplementary Insulation Requirements
- Excellent THD Characteristics

Electrical Parameters @ 25° C

Inductance (μ H Min.)	DCR (m Ω Max.)				Hipot (Vdc)			Turns Ratio (\pm 2%)	
	for 1 Second								
275 KHz, 0.1 Vrms	85	202	192	88	1500	1500	1500	1:1	1:1
9.35	Pins 1-12	Pins 4-9	Pins 6-7	Pins 11-2	Pin 1 to (4 & 6)	Pin 2 to (4 & 6)	Core to Pins (1 & 2)	Pins 1-12:11-2	Pins 4-9:6-7

Schematic

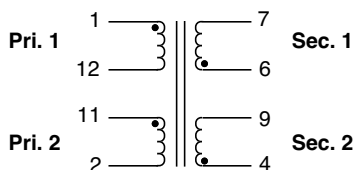

Package

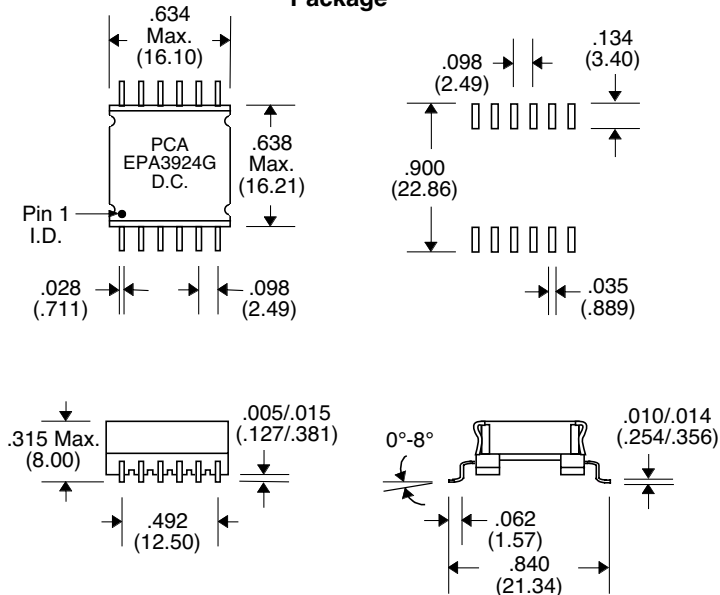

Unless Otherwise Specified Dimensions are in Inches /mm \pm .010 / .25