

SMD 28 Pin Passive Delay Lines

Zo Ohms ± 10%	Delay nS ± 5% or ±2 nS†	Tap Delays nS	Rise Time nS Max.	Atten. DB% Max.	J-Lead PCA Part Number	Gull-Wing PCA Part Number	Zo Ohms ± 10%	Delay nS ± 5% or ± 2 nS†	Tap Delays nS	Rise Time nS Max.	Atten. DB% Max.	J-Lead PCA Part Number	Gull-Wing PCA Part Number
100	25	2.5±0.5	5	2%	EP9130	EP9160	200	25	2.5±0.5	5	2%	EP9145	EP9175
100	30	3.0±0.5	6	2%	EP9131	EP9161	200	30	3.0±0.5	6	2%	EP9146	EP9176
100	35	3.5±0.5	7	2%	EP9132	EP9162	200	35	3.5±0.5	7	2%	EP9147	EP9177
100	40	4.0±0.5	8	2%	EP9133	EP9163	200	40	4.0±0.5	8	2%	EP9148	EP9178
100	45	4.5±0.5	9	2%	EP9134	EP9164	200	45	4.5±0.5	9	2%	EP9149	EP9179
100	50	5.0±1.0	10	2%	EP9135	EP9165	200	50	5.0±1.0	10	2%	EP9150	EP9180
100	60	6.0±1.0	12	2%	EP9136	EP9166	200	60	6.0±1.0	12	2%	EP9151	EP9181
100	75	7.5±1.0	15	4%	EP9137	EP9167	200	75	7.5±1.0	15	4%	EP9152	EP9182
100	100	10.0±2.0	20	4%	EP9138	EP9168	200	100	10.0±2.0	20	4%	EP9153	EP9183
100	125	12.5±2.0	25	7%	EP9139	EP9169	200	125	12.5±2.0	25	7%	EP9154	EP9184
100	150	15.0±2.0	30	8%	EP9140	EP9170	200	150	15.0±2.0	30	8%	EP9155	EP9185
100	175	17.5±2.0	35	10%	EP9141	EP9171	200	175	17.5±2.0	35	10%	EP9156	EP9186
100	200	20.0±2.0	40	10%	EP9142	EP9172	200	200	20.0±2.0	40	12%	EP9157	EP9187
100	225	22.5±2.0	45	10%	EP9143	EP9173	200	225	22.5±2.0	45	12%	EP9158	EP9188
100	250	25.0±2.0	50	12%	EP9144	EP9174	200	250	25.0±2.0	50	12%	EP9159	EP9189

† Whichever is greater.

DC Electrical Characteristics	Min	Max	Unit
Distortion		±10	%
Temperature Coefficient of Delay		100	PPM/°C
Insulation Resistance @ 100 Vdc	1K		Meg Ohms
Dielectric Strength		100	Vdc

Recommended Operating Conditions	Min	Max	Unit
PW*		200	%
D*		40	%
TA	0	70	°C

*These two values are inter-dependent.

Input Pulse Test Conditions @ 25°C		
V _{IN}	Pulse Input Voltage	3 Volts
PW	Pulse Width % of Total Delay	300 %
TR	Input Rise Time (10 - 90%)	2.0 nS
PRR	Pulse Repetition Rate @ T _d ≤ 150 nS	1.0 MHz
	Pulse Repetition Rate @ T _d > 150 nS	300 KHz

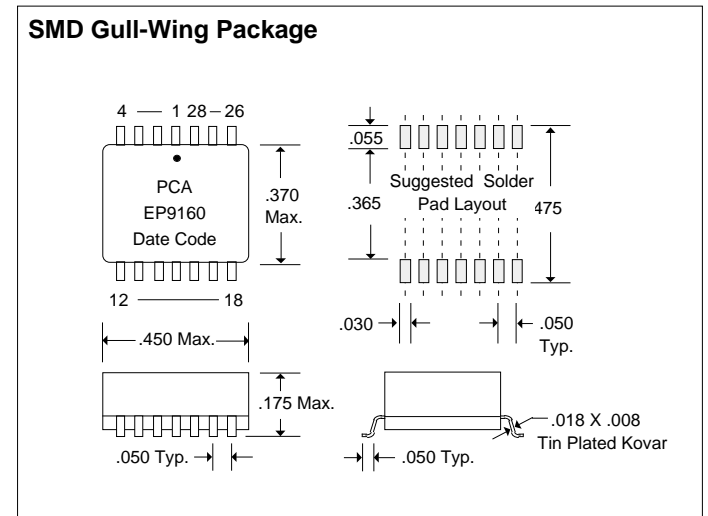
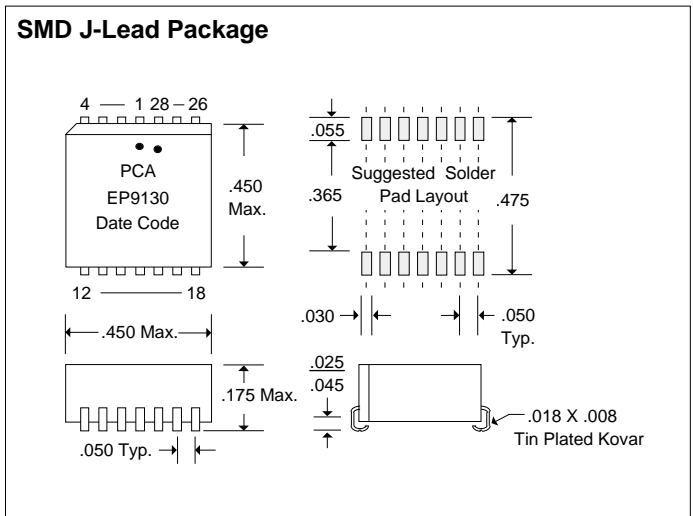
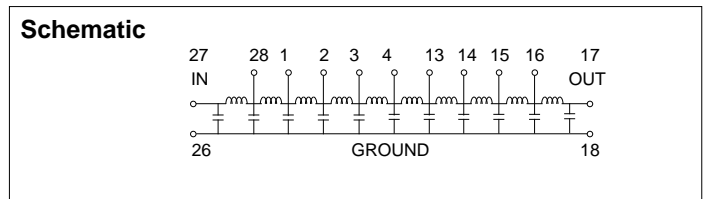

DSD91XXb Rev. A 2/5/96

QAF-CSO1a Rev. B 8/25/94

Unless Otherwise Noted Dimensions in Inches
Tolerances:
Fractional = ± 1/32
.XX = ± .030 .XXX = ± .010



16799 SCHOENBORN ST.
NORTH HILLS, CA 91343
TEL: (818) 892-0761
FAX: (818) 894-5791