



# JUMBO BUTTON AVALANCHE AUTOMOTIVE RECTIFIER

**JAAR80M**

**AVALANCHE VOLTAGE 37 to 41 Volts**

**CURRENT 80 Amperes**

**Technical Specifecation:**

**Features:**

- High power capability
- Economical
- Avalanche Voltage: 37V to 41V

**MECHANICAL DATA**

- Case: transfer molded plastic
- Epoxy: UL94-0 rate flame ratardant
- Polarity: Indicated by Cathode Band
- Technology vacuum soldered
- Lead: Plated slug, solderable per MIL-STD-202E Method 208C
- Weight: 0.085ounce, 2.40Grams

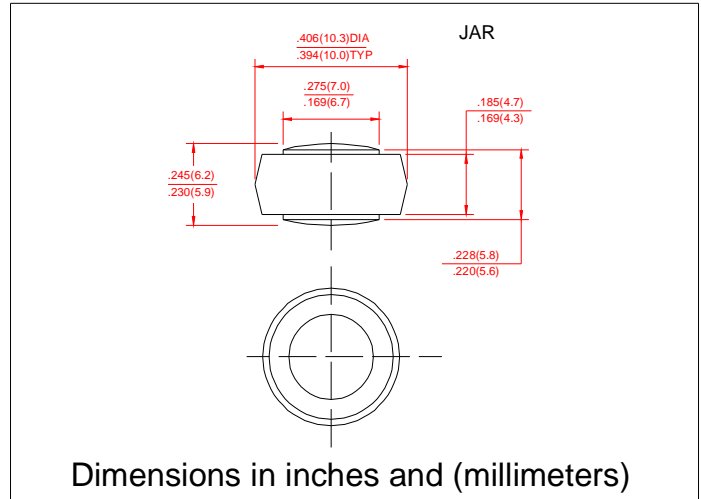

**MAXIMUM RATINGS AND ELECTRICAL CHARACTERISTICS**

- Ratings at 25°C ambient temperature unless otherwise specified
- Single Phase, half wave, 60Hz, resistive or inductive load
- For capacitive load derate current by 20%

Electrical Characteristics @ 25°C	SYMBOLS	MIN	NOMINAL	MAX	UNITS
Peak Repetitive Reverse Voltage	V <sub>RRM</sub>		28		Volts
Working Peak Reverse Voltage	V <sub>RRM</sub>		28		
DC Blocking Voltage	V <sub>DC</sub>		28		
Average Rectified Forward Current (T <sub>c</sub> =125°C)	I <sub>o</sub>		80		Amps
Repetitive Peak Reverse Surge Current T <sub>c</sub> =10msec Dury Cycle<1%	I <sub>RSM</sub>		80		Amps
Breakdown Voltage (V <sub>br</sub> @ir=100mA, T <sub>c</sub> =25°C)	V <sub>br1</sub>	37	39	41	Volts
Ir=90Amps, T <sub>c</sub> =150°C, PW=80usec	V <sub>br2</sub>			54	Volts
Forward Voltage Drop @If=100Amps<300usec	V <sub>F</sub>		1.0	1.05	Volts
Peak Forward Surge Current	I <sub>FSM</sub>		800		Amps
Reverse Leakage (V <sub>R</sub> =17Vdc) T <sub>A</sub> =25°C	I <sub>R</sub>		1.0	2.0	uAmps
Operating and Storage Junction Temperature Range	T <sub>J</sub> , T <sub>STG</sub>		-65 to +175		°C

**Notes:** 1. Enough heatsink must be considered in application.

