

213 x 239 x 209,5 mm

ETRI®

AC Centrifugal Blowers

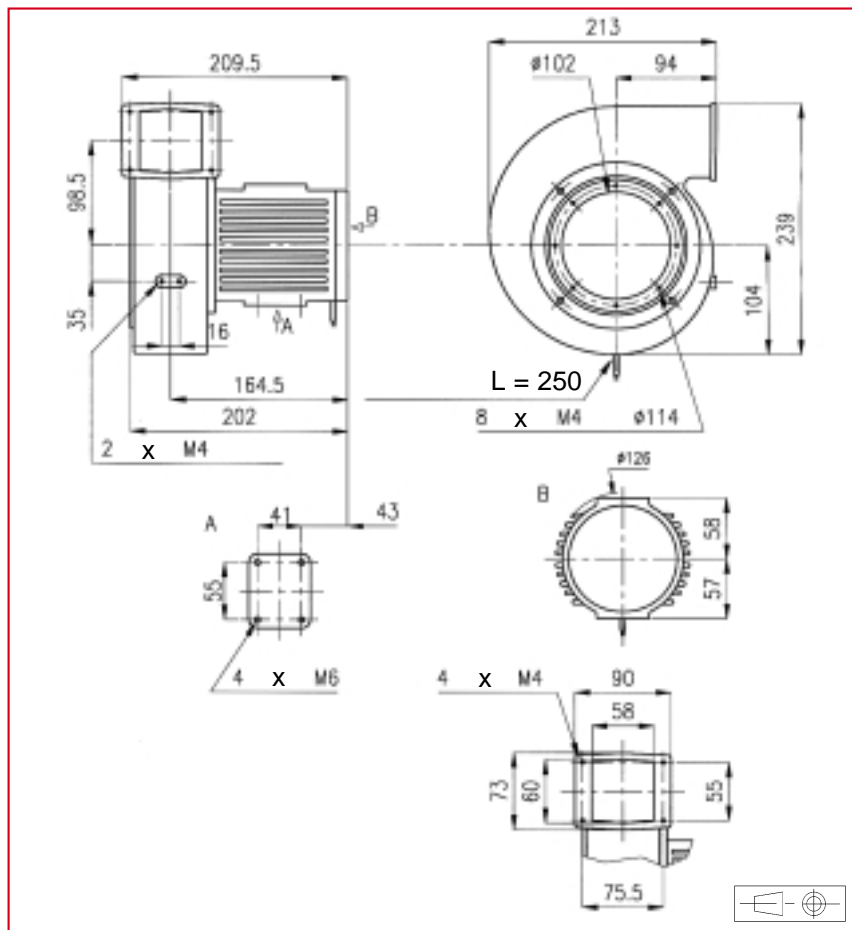

Approvals

GAM T1 LISTED

Life expectancy

L-10 LIFE AT 40°C:
25 000 hours

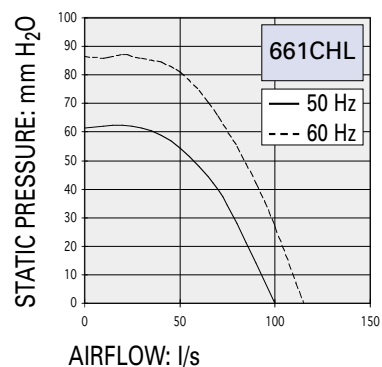

AC Motor

Housing material: aluminium
Wheel material: steel plate
Weight: 6,5 kg
Bearing system: ball bearings

Connection : flying leads

Available with:

- safety switch

Part number	Nominal voltage	Airflow	Noise level	Nominal speed	Frequency	Phases	Capacitor <i>(not included)</i>	Input power	Nominal current	Starting current	Operating temperature	
	V	l/s	dB(A)	RPM	Hz		µF	W	mA	mA	Min. °C	Max. °C
661CHL016DC13	220	100	68	2850	50	3		150	700	3400	- 10	70
	380	100	68	2850	50	3		150	400	2000	- 10	70
	220	115	70,5	3250	60	3		225	800	3450	- 10	70
	380	115	70,5	3250	60	3		225	460	2000	- 10	70
	220	100	68	2850	50	1	10	155	750	3100	- 10	70
	380	100	68	2850	50	1	3,2	155	450	1800	- 10	70
	220	115	70,5	3250	60	1	10	240	1100	2850	- 10	70
	380	115	70,5	3250	60	1	3,2	240	650	1700	- 10	70

Additional versions:

Salt spray protected - shock and vibration protected - marine specifications - wide temperature range

Accessories:

See pages: 157, 160 and 163