

Push Button PowerPath™ Controller with Supervisor

FEATURES

- Push-Button On/Off Control
- Automatic Low Loss Switchover Between DC Sources
- Wide Operating Voltage Range: 2.7V to 28V
- Low 25µA Shutdown Current
- Guaranteed Threshold Accuracy: ±1.5% of Monitored Voltage Over Temperature
- Adjustable Push-Button On/Off Timers
- Simple Interface Allows Graceful µP Shutdown
- Extendable House Keeping Wait Time Prior to Shutdown
- 200ms Reset Delay and 1.6s Watchdog Time Out
- ±8kV HBM ESD on $\overline{\text{PB}}$ Input
- 20 pin TSSOP and QFN (4mm × 4mm) Packages

APPLICATIONS

- Desktop and Notebook Computers
- Portable Instrumentations
- Cell Phones, PDA and Handheld Computers
- Servers and Computer Peripherals
- Battery Backup Systems

DESCRIPTION

The LTC[®]2952 is a power management device that features three main functions: push-button on/off control of system power, ideal diode power paths and system monitoring. The LTC2952's push-button input, which provides on/off control of system power, has independently adjustable ON and OFF debounce times. A simple microprocessor interface involving an interrupt signal allows for proper system housekeeping prior to power down.

The ideal diode power paths provide automatic low loss switchover between two DC sources by regulating two external P-channel MOSFETs to have a small 20mV forward drop.

High reliability systems may utilize the LTC2952's monitoring features to ensure system integrity. These features include: power-fail, voltage monitoring and µP watchdog.

The LTC2952 operates over a wide operating voltage range to accommodate a large variety of input power supplies. The part's combination of low 20mV external MOSFET regulation and very low standby current matches battery powered and power conscious application requirements.

LT, LT, LTC and LTM are registered trademarks of Linear Technology Corporation. All other trademarks are the property of their respective owners.

TYPICAL APPLICATION

Push-Button Controller with Automatic Switchover Between Adapter and Battery

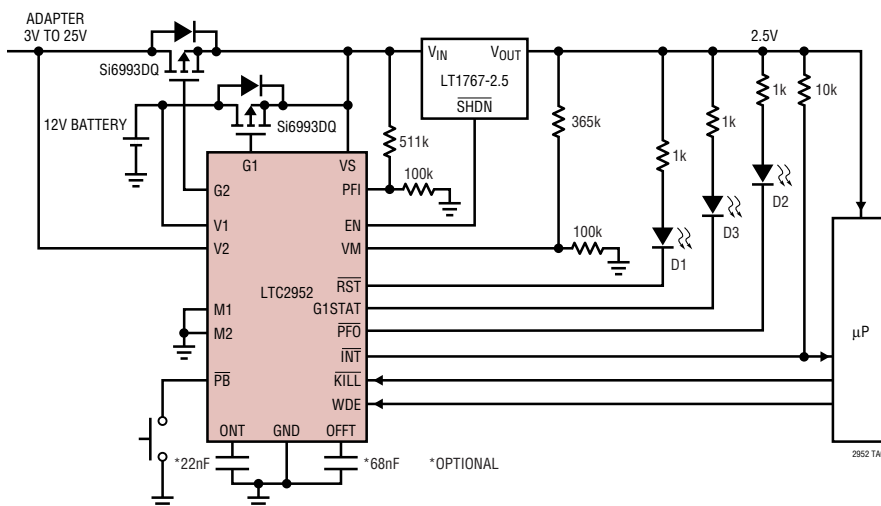

Ideal Diode vs Schottky Diode Forward Voltage Drop

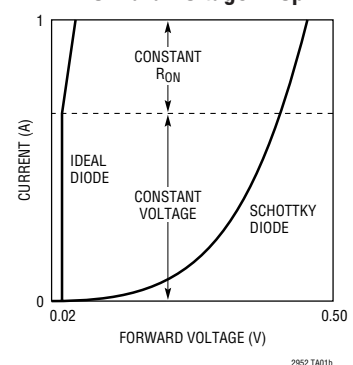

ABSOLUTE MAXIMUM RATINGS

(Notes 1, 2)

Supply Voltages

V1, V2, VS -0.3V to 30V

Input Voltages

PB -6V to MAX (V1, V2, VS) V

ONT, OFFT -0.3V to 3V

M1, M2, PFI, VM, WDE, KILL -0.3V to 7V

Output Voltages

G1, G2, EN -0.3V to MAX (V1, V2, VS) V

G1STAT, PFO, RST, INT -0.3V to 7V

Input Currents

PB -1mA to 100 μ A

Operating Temperature Range

LTC2952C 0°C to 70°C

LTC2952I -40°C to 85°C

Storage Temperature Range

Lead Temperature (Soldering, 10 sec) 300°C

PACKAGE/ORDER INFORMATION

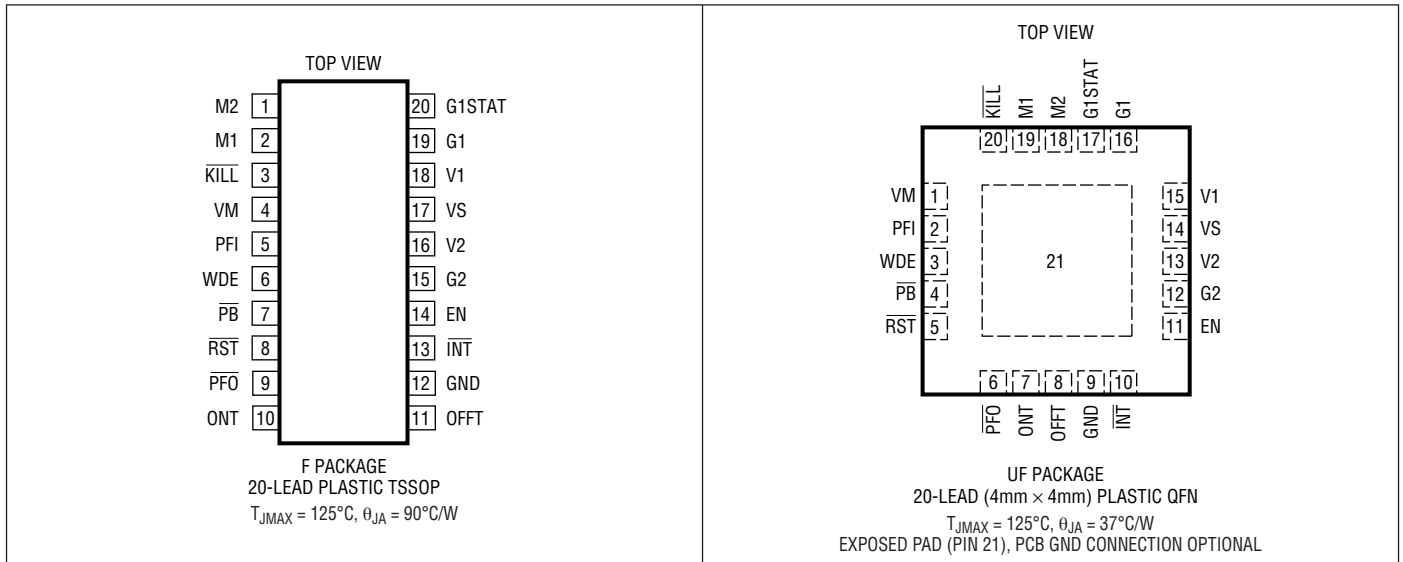

| ORDER PART NUMBER | F20 PART MARKING | ORDER PART NUMBER | UF20 PART MARKING |
|-------------------|------------------|-------------------|-------------------|
| LTC2952CF | LTC2952CF | LTC2952CUF | 2952 |
| LTC2952IF | LTC2952IF | LTC2952IUF | 2952 |

Order Options Tape and Reel: Add #TR
Lead Free: Add #PBF Lead Free Tape and Reel: Add #TRPBF
Lead Free Part Marking: <http://www.linear.com/leadfree/>

Consult LTC Marketing for parts specified with wider operating temperature ranges.

ELECTRICAL CHARACTERISTICS

The ● denotes the specifications which apply over the full operating temperature range, otherwise specifications are at $T_A = 25^\circ\text{C}$. $V_1 = V_2 = V_S = 2.7\text{V}$ to 28V unless otherwise noted. (Notes 2, 3)

| SYMBOL | PARAMETER | CONDITIONS | MIN | TYP | MAX | UNITS |
|------------------------|--|--|-------|-----|---------|---------------|
| V_{MAX} | Operating Supply Voltage | V_1, V_2 or V_S | ● 2.7 | | 28 | V |
| $I_{\text{IN_OFF}}$ | Quiescent Supply Current Both Ideal Diodes Switched Off ($M_1 = \text{Open}, M_2 = 0\text{V}$) | $V_1 = 2.7\text{V}$ to $28\text{V}, V_2 = 0\text{V}, V_S = \text{Open}$ or $V_2 = 2.7\text{V}$ to $28\text{V}, V_1 = 0\text{V}, V_S = \text{Open}$. Measured Current at V_1 or V_2 . | ● | 24 | 60 | μA |
| | | $V_1 = 2.7\text{V}$ to $28\text{V}, V_2 = 3.5\text{V}, V_S = \text{Open}$. Measured Current at V_1 . | ● | 5 | 15 | μA |
| | | $V_1 = 2.7\text{V}$ to $28\text{V}, V_2 = 3.5\text{V}, V_S = \text{Open}$. Measured Current at V_2 . | ● | 23 | 50 | μA |
| $I_{\text{IN_ON}}$ | Quiescent Supply Current Both Ideal Diodes Switched On ($M_1 = 0\text{V}, M_2 = 0\text{V}$) | $V_1 = V_S = 2.7\text{V}$ to $28\text{V}, V_2 = 0\text{V}$ or $V_2 = V_S = 2.7\text{V}$ to $28\text{V}, V_1 = 0\text{V}$. Measured Combined Current at V_1 and V_S or V_2 and V_S . | ● | 65 | 170 | μA |
| $V_{2\text{PREF_TH}}$ | V_2 Preferential Threshold Voltage ($M_1 = \text{Open}, M_2 = 0\text{V}$) (Note 4) | $V_1 = 28\text{V}, V_S = \text{Open}$. | ● | 3.3 | 3.8 | V |
| I_{LEAK} | V_1, V_2 and V_S Inter Pin Leakage to the Highest Supply | $V_1 = 28\text{V}, V_2 = V_S = 0\text{V}; V_1 = V_S = 0\text{V}, V_2 = 28\text{V}; V_1 = V_2 = 0\text{V}, V_S = 28\text{V}$ | | | ± 3 | μA |

Ideal Diode Function

| | | | | | | | |
|-------------------------|--|---|---|------|------|-----|---------------|
| V_{FR} | Ideal Diode Power Path Forward Regulation Voltage | $(V_1 \text{ or } V_2) - V_S, 2.7\text{V} \leq (V_1 \text{ or } V_2) \leq 28\text{V}$ | ● | 10 | 20 | 35 | mV |
| V_{RTO} | Ideal Diode Power Path Fast Reverse Turn-Off Threshold Voltage | $(V_1 \text{ or } V_2) - V_S, 2.7\text{V} \leq (V_1 \text{ or } V_2) \leq 28\text{V}$ $\Delta I_G \leq -100\mu\text{A/mV}$ | ● | -20 | -35 | -64 | mV |
| $I_{\text{G(SRC)}}$ | Gate Turn-Off Current | $G_1 = G_2 = V_{\text{MAX}} - 1.5\text{V}$ | ● | -2 | -5 | -10 | μA |
| $I_{\text{G(SNK)}}$ | Gate Turn-On Current | $V_1 = V_2 = 2.7\text{V}$ to $28\text{V}, V_S = (V_1 \text{ or } V_2) - 40\text{mV}, G_1 = G_2 = V_{\text{MAX}} - 1.5\text{V}$. | ● | 2 | 5 | 10 | μA |
| $I_{\text{G(FASTSRC)}}$ | Gate Fast Turn-Off Source Current | $V_1 = V_2 = 2.7\text{V}$ to $28\text{V}, V_S = (V_1 \text{ or } V_2) + 0.1\text{V}, G_1 = G_2 = V_{\text{MAX}} - 1.5\text{V}$. | ● | -0.5 | -2.5 | -10 | mA |
| $I_{\text{G(FASTSNK)}}$ | Gate Fast Turn-On Sink Current | $V_1 = V_2 = 5\text{V}$ to $28\text{V}, V_S = (V_1 \text{ or } V_2) - 0.1\text{V}, G_1 = G_2 = V_{\text{MAX}} - 1.5\text{V}$. | ● | 0.3 | 0.7 | 2 | mA |
| $V_{\text{G(ON)}}$ | Gate Clamp Voltage | $I_{\text{GX}} = 2\mu\text{A}, V_X = 8\text{V}$ to $28\text{V}, V_S = V_X - 0.1\text{V}$ Measure $V_X - V_{\text{GX}}$ | ● | 6 | 7 | 8 | V |
| $V_{\text{G(OFF)}}$ | Gate Off Voltage | $I_{\text{GX}} = -2\mu\text{A}, V_X = 2.7\text{V}$ to $28\text{V}, V_S = V_X + 0.1\text{V}$ Measure $V_{\text{MAX}} - V_{\text{GX}}$ | ● | | 0.2 | 0.4 | V |
| $t_{\text{G(ON)}}$ | Gate Turn-On Time | $V_{\text{G(OFF)}} \text{ to } V_{\text{GS}} \leq -3\text{V}, C_{\text{GATE}} = 1\text{nF}$ (Note 5), $V_1 = V_2 = 12\text{V}$ | | 0.1 | 2.5 | 10 | μs |
| $t_{\text{G(OFF)}}$ | Gate Turn-Off Time | $V_{\text{G(ON)}} \text{ to } V_{\text{GS}} \geq -1.5\text{V}, C_{\text{GATE}} = 1\text{nF}$ (Note 6), $V_1 = V_2 = 12\text{V}$ | | 0.1 | 2.5 | 10 | μs |

Push-Button Pin (PB)

| | | | | | | | |
|----------------------|----------------------------|--|---|------|------|---------|---------------|
| $V_{\text{PB(VOC)}}$ | PB Open Circuit Voltage | $I_{\text{PB}} = -1\mu\text{A}$ | ● | 1 | 4 | 6 | V |
| I_{PB} | PB Input Current | $V_{\text{PB(VOC)}} < V_{\text{PB}} \leq 28\text{V}$ | ● | | | ± 1 | μA |
| | | $0\text{V} \leq V_{\text{PB}} < V_{\text{PB(VOC)}}$ | ● | -1 | -10 | -25 | μA |
| $V_{\text{TH_PB}}$ | PB Input Threshold Voltage | PB Falling From High to Low | ● | 0.65 | 0.77 | 0.8 | V |
| $V_{\text{HYS_PB}}$ | PB Input Hysteresis | | ● | 10 | 25 | 150 | mV |

ELECTRICAL CHARACTERISTICS

The ● denotes the specifications which apply over the full operating temperature range, otherwise specifications are at $T_A = 25^\circ\text{C}$. $V_1 = V_2 = V_S = 2.7\text{V TO } 28\text{V}$ unless otherwise noted. (Notes 2, 3)

| SYMBOL | PARAMETER | CONDITIONS | | MIN | TYP | MAX | UNITS |
|--|---|--|---|-------|-------|-------|-------|
| Debounce Time Pins (ONT, OFFT) | | | | | | | |
| $I_{\text{ONT,OFFT}}$ | ONT/OFFT Pull-Up/Pull-Down Current When Timer is Active | $V_{\text{ONT}}, V_{\text{OFFT}} = 0\text{V}$ (Pull-Up), $V_{\text{ONT}}, V_{\text{OFFT}} = 1.5\text{V}$ (Pull-Down) | ● | ±1.6 | ±2.0 | ±2.4 | μA |
| $t_{\text{DB,ON/OFF}}$ | Internal Default On-Time/Off-Time | $t_{\text{DB,ON}}$: $C_{\text{ONT}} = \text{Open}$, Measured Time Between $\overline{\text{PB}}_{\text{Low}} \rightarrow \text{EN High}$, $t_{\text{DB,OFF}}$: Measured Time Between $\overline{\text{PB}}_{\text{Low}} \rightarrow \text{INT High}$ | ● | 18 | 26 | 34 | ms |
| $t_{\text{ONT,OFFT}}$ | Additional Adjustable Turn-On/Turn-Off Time (Note 7) | $C_{\text{ONT}} = 1500\text{pF}$, $C_{\text{OFFT}} = 1500\text{pF}$ | ● | 10 | 15 | 20 | ms |
| Accurate Comparator Input Pins (VM, PFI, M1, M2, $\overline{\text{KILL}}$) | | | | | | | |
| $V_{\text{TH_VM}}$ | VM Input Reset Threshold | Both Falling and Rising | ● | 0.492 | 0.500 | 0.508 | V |
| V_{TH} | PFI, M1, M2, $\overline{\text{KILL}}$ Input Threshold Voltage | Falling | ● | 0.492 | 0.500 | 0.508 | V |
| V_{HYS} | PFI, M1, M2, $\overline{\text{KILL}}$ Input Hysteresis | | ● | 5 | 15 | 25 | mV |
| $I_{\text{IN_LKG}}$ | VM, PFI, M2, $\overline{\text{KILL}}$ Input Current | $V = 0.5\text{V}$ | ● | | | ±0.1 | μA |
| $I_{\text{M1_SRC}}$ | M1 Input Pull-Up Current | $M1 = 1\text{V}$ | ● | -1.5 | -3 | -5 | μA |
| $V_{\text{M1(VOC)}}$ | M1 Voltage Open Circuit | | ● | 1 | 4 | 6 | V |
| $I_{\text{M1_LKG}}$ | M1 Input Leak Current | $M1 = 6\text{V}$ | ● | | | ±0.1 | μA |
| Watch-Dog/Extend Pin (WDE) | | | | | | | |
| $V_{\text{WDE(H,TH)}}$ | Input High Threshold Voltage | | ● | | | 1.5 | V |
| $V_{\text{WDE(L,TH)}}$ | Input Low Threshold Voltage | | ● | 0.3 | | | V |
| $I_{\text{WDE(IN,HL)}}$ | High Low Input Current (Note 8) | | ● | | | ±25 | μA |
| $I_{\text{WDE(IN,HZ)}}$ | High Z Input Current | $V_{\text{WDE}} = 0.7\text{V}, 1.1\text{V}$ | ● | ±10 | | | μA |
| Open Drain Output Pins (G1STAT, $\overline{\text{INT}}$, RST, PFO) | | | | | | | |
| $I_{\text{OUT_LKG}}$ | Leakage Current | $V_{\text{PIN}} = 5\text{V}$ | ● | | | ±1 | μA |
| V_{OL} | Voltage Output Low | $I_{\text{PIN}} = 1\text{mA}$ | ● | | | 0.4 | V |
| High Voltage Open Drain Output Pin (EN) | | | | | | | |
| $I_{\text{EN(LKG)}}$ | EN Leakage Current | $V_{\text{EN}} = 28\text{V}$, EN Sink Current Off | ● | | | ±1 | μA |
| $V_{\text{EN(VOL)}}$ | EN Voltage Output Low | $I_{\text{EN}} = 3\text{mA}$ | ● | | | 0.4 | V |
| | | $V_1 = 1.2\text{V}$ and/or $V_2 = 1.2\text{V}$, $I_{\text{EN}} = 100\mu\text{A}$ | ● | | 0.05 | 0.3 | V |
| Voltage Monitor/Watchdog Timing | | | | | | | |
| t_{RST} | Reset Time-Out Period | | ● | 140 | 200 | 260 | ms |
| t_{WDE} | Watch-Dog Time-Out Period | | ● | 1.1 | 1.6 | 2.1 | s |
| $t_{\text{WDE(PW MIN)}}$ | Minimum Period Between Consecutive Edges | | ● | | 5 | 10 | μs |
| $t_{\text{VM(UV)}}$ | VM Undervoltage Detect to $\overline{\text{RST}}$ | VM Less Than $V_{\text{TH_VM}}$ by more than 1% | | | 150 | | μs |
| t_{PFI} | PFI Delay to PFO | PFI More or Less Than $V_{\text{PFI_TH}}$ by more than 1% | | | 150 | | μs |

ELECTRICAL CHARACTERISTICS

The ● denotes the specifications which apply over the full operating temperature range, otherwise specifications are at $T_A = 25^\circ\text{C}$. $V_1 = V_2 = V_S = 2.7\text{V}$ to 28V unless otherwise noted. (Notes 2, 3)

| SYMBOL | PARAMETER | CONDITIONS | MIN | TYP | MAX | UNITS | |
|--|---|---|------|-----|-----|---------------|----|
| μP Handshake Timing | | | | | | | |
| $t_{\overline{\text{INT}}}(\text{MIN})$ | $\overline{\text{INT}}$ Minimum Pulse Width | Minimum Measured Time $\overline{\text{PB}}$ Rising to $\overline{\text{INT}}$ Rising | ● 10 | 50 | 250 | μs | |
| $t_{\overline{\text{KILL}}}(\text{PW})$ | $\overline{\text{KILL}}$ Minimum Pulse Width | Full Swing Pulse From 5V to 0V | ● | 150 | 500 | μs | |
| $t_{\overline{\text{KILL,ON BLANK}}}$ | $\overline{\text{KILL}}$ ON Blanking (Note 9) | $\overline{\text{KILL}} = 0\text{V}$, Measured Time Between EN Rising \rightarrow EN Falling | ● | 270 | 400 | 530 | ms |
| $t_{\overline{\text{KILL, OFF WAIT}}}$ | $\overline{\text{KILL}}$ Wait Time (Note 10) | $\overline{\text{KILL}} = 1\text{V}$, $C_{\text{OFFT}} = \text{OPEN}$, Measured Time Between $\overline{\text{INT}}$ Falling \rightarrow EN Falling | ● | 270 | 400 | 530 | ms |
| $t_{\text{EN, LOCKOUT}}$ | Enable Lockout Time (Note 11) | Measured Time Between EN Falling \rightarrow EN Rising | ● | 270 | 400 | 530 | ms |

Note 1: Stresses beyond those listed under Absolute Maximum Ratings may cause permanent damage to the device. Exposure to any Absolute Maximum Rating condition for extended periods may affect device reliability and lifetime.

Note 2: The greatest of V_1 , V_2 or V_S is the internal supply voltage (V_{MAX}).

Note 3: All currents into pins are positive; all voltages are referenced to GND unless otherwise noted.

Note 4: $V_{2\text{PREF_TH}}$ is the minimum voltage level at which V_2 becomes the preferential source of quiescent current when both of the ideal diodes are off.

Note 5: V_S is stepped from $(V_1 \text{ or } V_2) + 0.2\text{V}$ to $(V_1 \text{ or } V_2) - 0.2\text{V}$ to trigger the event. The gate voltages are initially $V_{\text{G(OFF)}}$.

Note 6: V_S is stepped from $V_X - 0.2\text{V}$ to $V_X + 0.2\text{V}$ to trigger the event. Gate voltages are initially clamped at $V_{\text{G(ON)}}$.

Note 7: The Adjustable Turn-On and Turn-Off timer period is the adjustable debounce period following the Internal Default-On and Default-Off timer period respectively.

Note 8: The input current to the three-state WDE pin are the pull-up and the pull-down current when the pin is either set to 3.3V or GND respectively. In the Open state, the maximum pull-up or pull-down leakage current permissible is $10\mu\text{A}$.

Note 9: The Turn-On $\overline{\text{KILL}}$ Blanking Time is the waiting period immediately following the EN pin switching high; at the end of this period the input to the $\overline{\text{KILL}}$ needs to be high to indicate that the system has powered up properly, otherwise the EN pin is immediately switched low.

Note 10: The $\overline{\text{KILL}}$ Wait Time during the power down process is the wait period immediately following a valid turn-off command until the EN pin switches low.

Note 11: The Enable Lockout Time is the minimum wait time between the last falling edge and the next rising edge on the EN pin.

TIMING DIAGRAMS

Ideal Diode Function – Gate Turn-On and Turn-Off Time

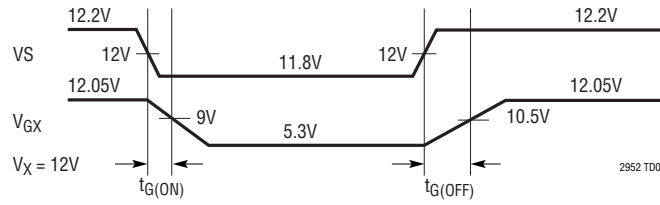

Push-Button Debounce Times, \overline{KILL} Wait Time and Enable Lockout Time with \overline{KILL} Above Threshold

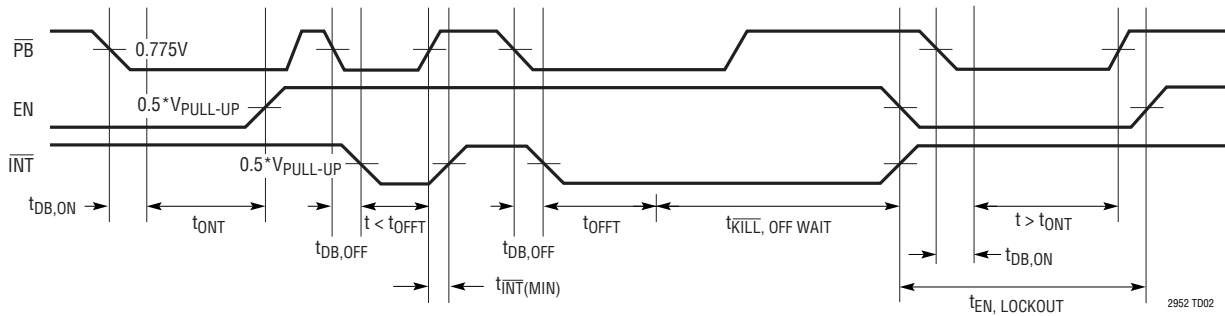

\overline{KILL} ON Blanking with \overline{KILL} Below Threshold

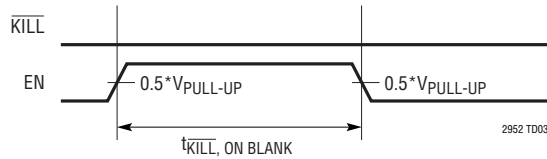

TIMING DIAGRAMS

PFI and $\overline{\text{PFO}}$

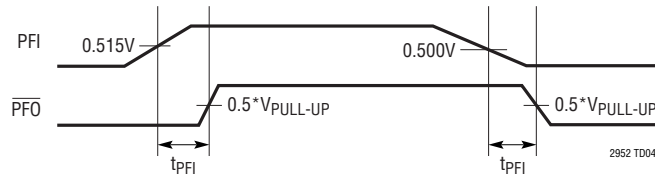

WDE Minimum Pulse Width

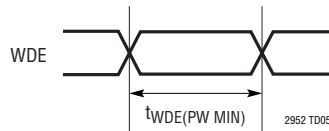

VM, WDE and $\overline{\text{RST}}$

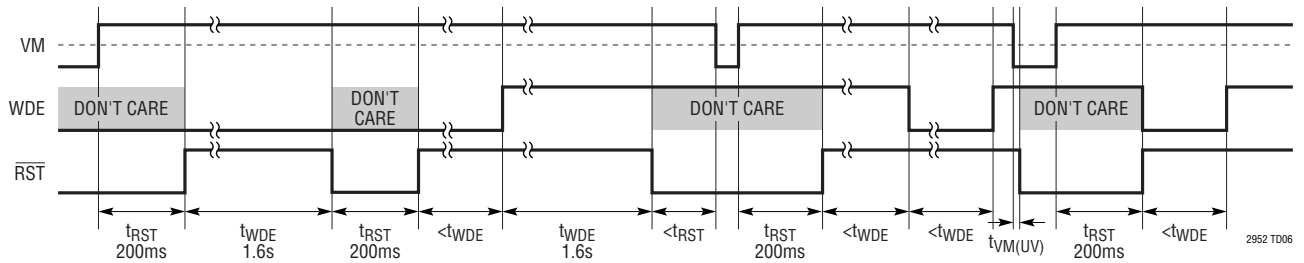

TYPICAL PERFORMANCE CHARACTERISTICS

Specifications are at $T_A = 25^\circ\text{C}$ unless otherwise noted.

I_{IN_OFF} vs Input Supply Voltage at Different Temperatures

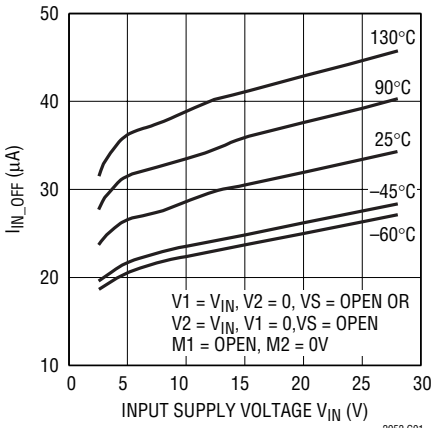

2952 G01

I_{IN_ON} vs Input Supply Voltage at Different Temperatures

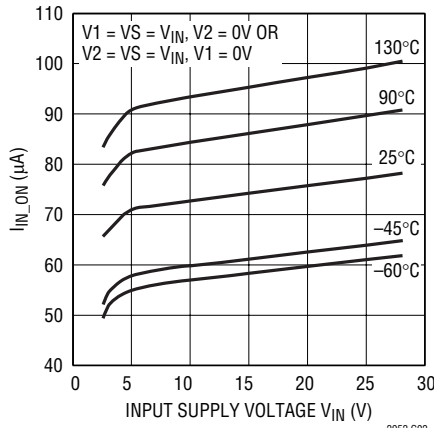

2952 G02

V_2 Preferential Threshold vs Temperature

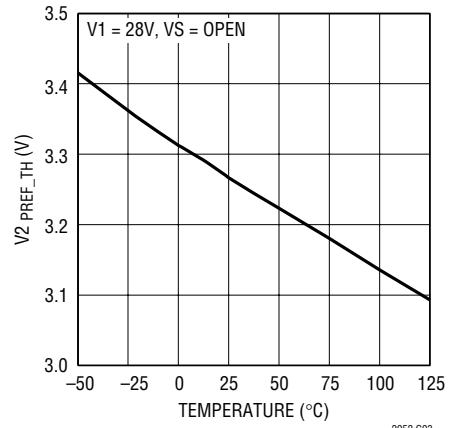

2952 G03

Worst Case Supply to Supply Leakage vs Temperature

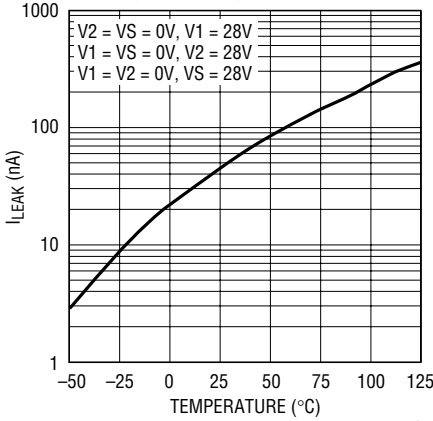

2952 G04

\overline{PB} Current vs \overline{PB} Voltage

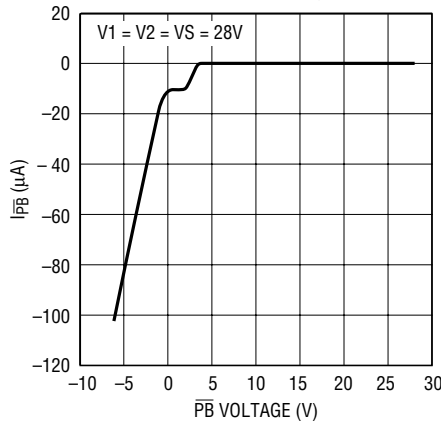

2952 G06

ONT/OFFT Pull-Up/Pull-Down Current vs Temperature

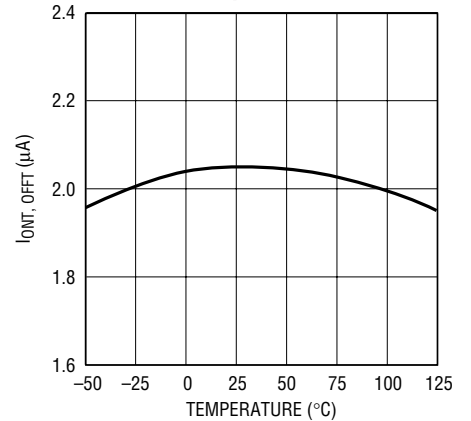

2952 G08

Total Turn-On/Turn-Off Time vs ONT/OFFT Capacitors Value

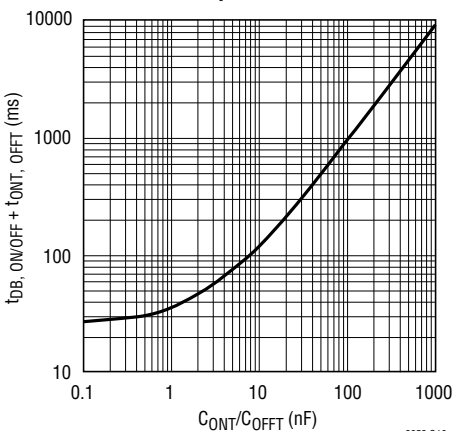

2952 G10

KILL, PFI, M1 and M2 Falling Input Threshold Voltage vs Temperature

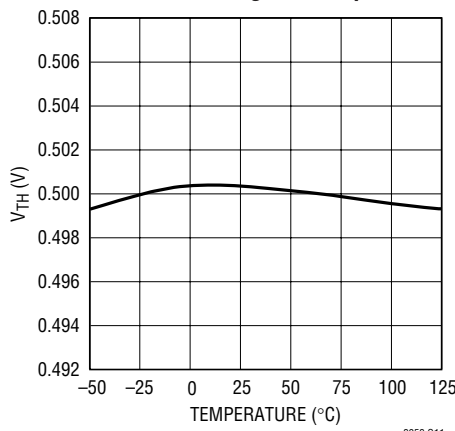

2952 G11

VM Input Reset Threshold Voltage vs Temperature

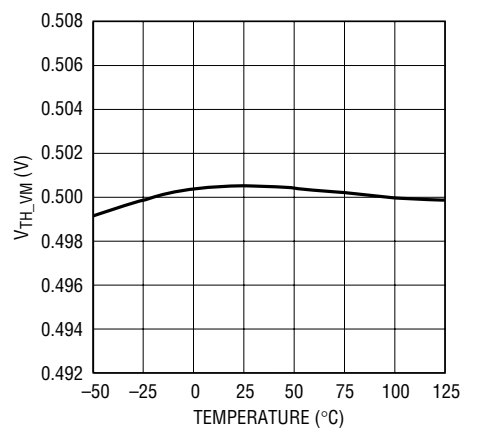

2952 G13

2952f

TYPICAL PERFORMANCE CHARACTERISTICS

Specifications are at $T_A = 25^\circ\text{C}$ unless otherwise noted.

Typical Transient Duration vs Comparator Overdrive (VM, KILL, PFI, M1 and M2)

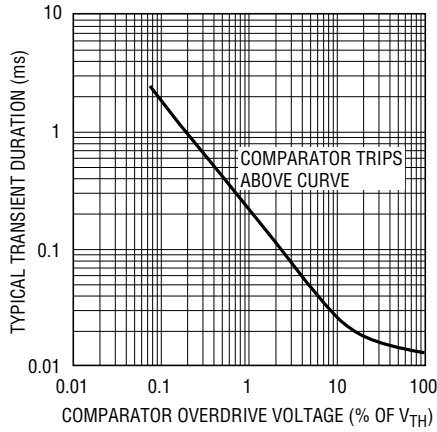

2952 G14

$\overline{\text{KILL}}$ ON Blanking, $\overline{\text{KILL}}$ Wait Time, Enable Lockout Time vs Temperature at Different Input Voltages

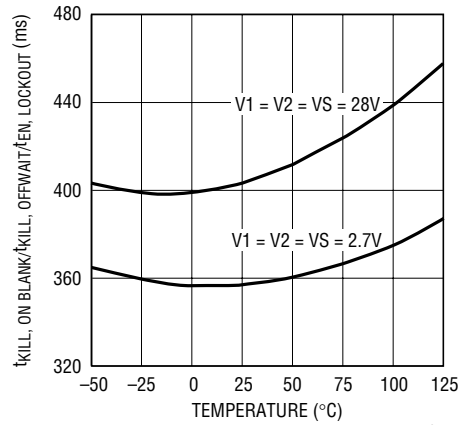

2952 G16

Reset Time-Out Period vs Temperature at Different Input Voltages

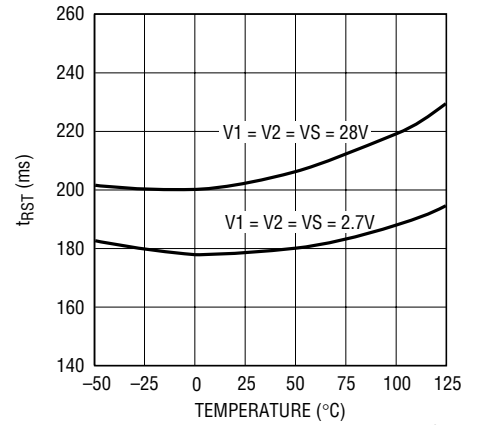

2952 G17

Watch Dog Time Period vs Temperature at Different Input Voltages

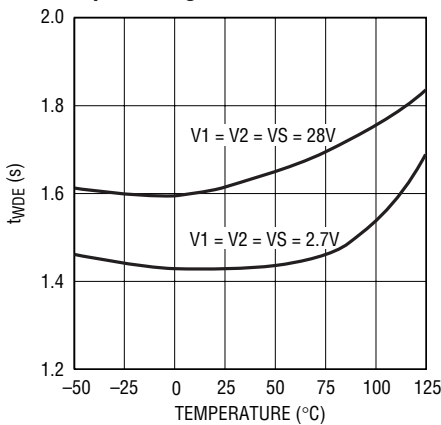

2952 G18

G1STAT, $\overline{\text{PFO}}$, $\overline{\text{INT}}$ and $\overline{\text{RST}}$ Pull-Down Current vs Supply Voltage

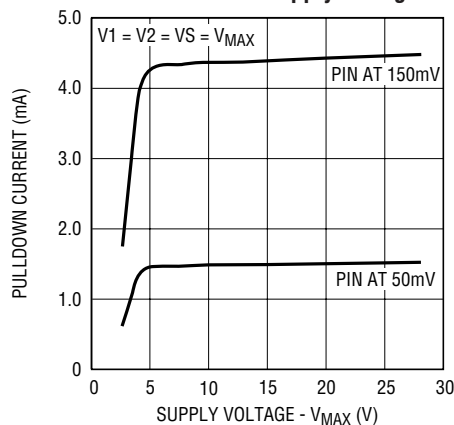

2952 G19

G1STAT, $\overline{\text{PFO}}$, $\overline{\text{INT}}$ and $\overline{\text{RST}}$ Voltage Output Low vs Pull-Down Current at Different Temperatures

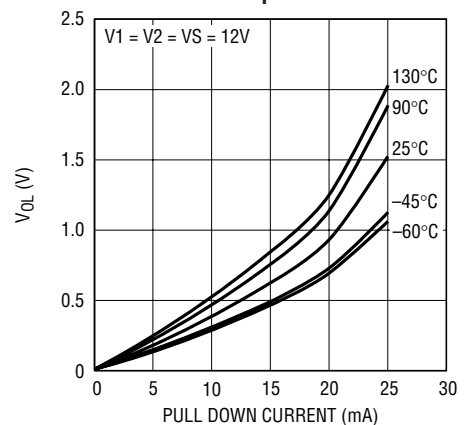

2952 G20

EN Pull-Down Current vs Supply Voltage

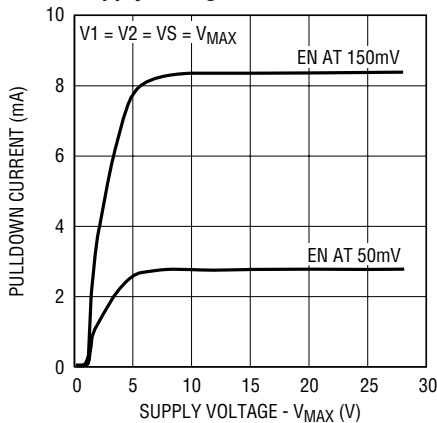

2952 G21

EN Pull-Down Current vs Supply Voltage

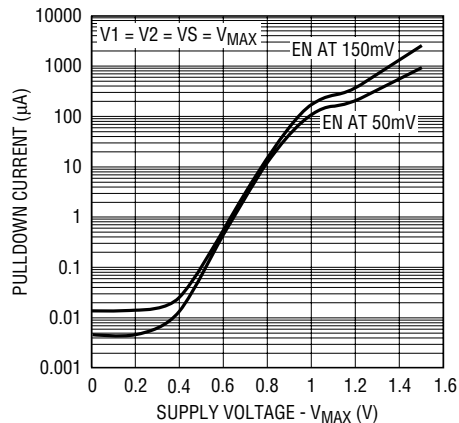

2952 G22

EN Voltage Output Low vs Pull-Down Current at Different Temperatures

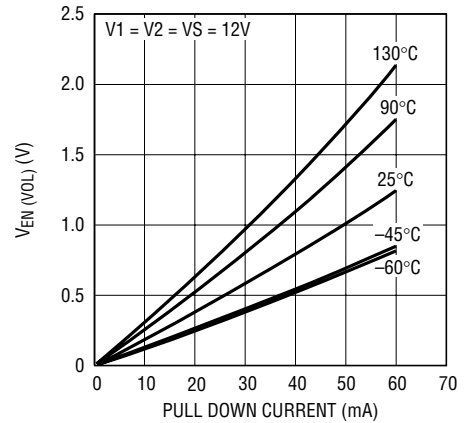

2952 G23

PIN FUNCTIONS (TSSOP/QFN)

EN (Pin 14/Pin 11): DC/DC Enable Output. This pin is a high voltage open drain pull-down used to control system power. EN pin goes high impedance after an initial turn-on command (via either the digital on or a valid push-button on – refer to the Applications Information section). EN pin pulls low at the end of a valid power-down sequence, or when KILL pin is driven low anytime after a valid power-up sequence.

Exposed Pad (Pin 21, QFN Package): The Exposed Pad may be left open or connected to device ground.

G1 (Pin 19/Pin 16): Primary P-Channel MOSFET Gate Drive Output. When the primary ideal diode function is enabled and in regulation, the ideal diode controller drives this pin to maintain a forward voltage (V_{FR}) of 20mV between the V1 and VS pins. When another power source is driving the VS pin, causing the voltage level at the VS pin to be greater than the voltage level at the V1 pin or when the primary ideal diode driver is disabled via the mode select input pins, this pin pulls up to the MAX(V1, VS) voltage, turning off the primary P-channel power switch. Leave this pin open when primary ideal diode function is not used.

G1STAT (Pin 20/Pin 17): Open-Drain Primary Ideal Diode Status Output. When the primary P-channel power switch is off, the G1STAT pin will go from an open state to a strong pull-down. This pin can be used to signal the state of the primary ideal diode power path to a microcontroller. Leave this pin open or tied to GND when unused.

G2 (Pin 15/Pin 12): Secondary P-Channel MOSFET Gate Drive Output. When the secondary ideal diode function is enabled and in regulation, the ideal diode controller drives this pin to maintain a forward voltage (V_{FR}) of 20mV between the V2 and VS pins. When another power source is driving the VS pin, causing the voltage level at the VS pin to be greater than the voltage level at the V2 pin or when the secondary ideal diode driver is disabled via the mode select input pins, this pin pulls up to the MAX(V2, VS) voltage, turning off the secondary P-channel power switch. Leave this pin open when secondary ideal diode function is not used.

GND (Pin 12/Pin 9): Device Ground.

$\overline{\text{INT}}$ (Pin 13/Pin 10): Interrupt Output. This pin is an open drain pull-down pin used to signal the system that a power shutdown is imminent. The $\overline{\text{INT}}$ pin asserts low 26ms after the initial falling edge of the push button off event and during the power down sequence. Leave this pin open or tied to GND if interrupt signal is unused.

KILL (Pin 3/Pin 20): System Power Shutdown Input. Setting this pin low asserts the EN pin low. In modes where M1 is above threshold, setting this pin low also shuts off the ideal diodes. During system turn-on, input to this pin is ignored until 500ms ($t_{\text{KILL,ON BLANK}}$) after the EN pin first becomes high impedance. This pin has an accurate 0.5V falling threshold and can be used as a voltage monitor input.

M1 (Pin 2/Pin 19): Mode Select Input 1. Input to an accurate comparator with 0.5V falling threshold and 15mV hysteresis. Has a 3 μ A internal pull-up to an internal supply (4V). Together with M2 determines the ideal power path and on/off control behavior of the part. Refer to the Operation and Applications Information sections for configurations based on the voltage levels at M1 and M2.

M2 (Pin 1/Pin 18): Mode Select Input 2. High impedance input to an accurate comparator with 0.5V falling threshold and 15mV hysteresis. When M1 is low, M2 controls whether the primary (G1) ideal diode function is enabled. When M1 is high, M2 acts as a digital on/off control input: A rising edge on this pin is interpreted as a turn-on command and a falling edge is interpreted as a turn-off command. Refer to the Operation and Applications Information sections for configurations based on the voltage levels at M1 and M2.

OFFT (Pin 11/Pin 8): Off Timing Input. Attach 110pF of external capacitance (C_{OFFT}) to GND for each additional millisecond of turn-off debounce time beyond the internally set 26ms. Leave open if additional debounce time is not needed.

PIN FUNCTIONS (TSSOP/QFN)

ONT (Pin 10/Pin 7): On Timing Input. Attach 110pF of external capacitance (C_{ONT}) to GND for each additional millisecond of turn-on debounce time beyond the internally set 26ms. Leave open if additional debounce time is not needed.

\overline{PB} (Pin 7/Pin 4): Push-Button Input. Input to a comparator with 0.775V falling threshold and 25mV hysteresis. \overline{PB} has a 10 μ A internal pull-up to an internal supply (4V). This pin provides on/off power supply control via the EN pin, which is typically connected to an external DC/DC converter. Setting the \overline{PB} pin low for a time determined by the ONT timing capacitor toggles the EN pin high impedance. Letting this pin toggle high and then setting this pin low again for 26ms asserts \overline{INT} low. After the \overline{INT} pin asserts low, if the \overline{PB} pin is still held low for a time determined by the OFFT timing capacitor, the process of turning off the system power begins. At the end of the turn-off process, the EN pin is set low. Leave this pin open if push button function is not used.

PFI (Pin 5/Pin 2): Power Fail Input. High impedance input to an accurate comparator with a 0.5V falling threshold and 15mV hysteresis. This pin controls the state of the \overline{PFO} output pin. Tie to device GND if power fail monitoring function is not used.

\overline{PFO} (Pin 9/Pin 6): Power Fail Output. This pin is an open drain pull-down which pulls low when the PFI input is below 0.5V. Leave this pin open or tied to GND if power fail monitoring function is not used.

\overline{RST} (Pin 8/Pin 5): Reset Output. This pin is an open drain pull-down. Pulls low when VM input is below 0.5V and held low for 200ms after VM input is above 0.5V. Also pulls low for 200ms when the watchdog timer (1.6s) is allowed to time out. Leave this pin open or tied to GND if voltage monitoring function is not used.

V1 (Pin 18/Pin 15): Primary Input Supply Voltage: 2.7V to 28V. Supplies power to the internal circuitry and is the anode input of the primary ideal diode driver (the cathode input to the ideal diode drivers is the VS pin). A battery or other primary power source usually provides power to this input. Minimize the capacitance on this pin in applications

where the pin can be high impedance (disconnected or inherent high source impedance). Otherwise, an optional bypass capacitor to ground in the range of 0.1 μ F to 10 μ F can be used.

V2 (Pin 16/Pin 13): Secondary Input Supply Voltage: 2.7V to 28V. Supplies power to the internal circuitry and is the anode input of the secondary ideal diode driver (the cathode input to the ideal diode drivers is the VS pin). A secondary power source such as a wall adapter, usually provides power to this input. Minimize the capacitance on this pin in applications where the pin can be high impedance (disconnected or inherent high source impedance). Otherwise, an optional bypass capacitor to ground in the range of 0.1 μ F to 10 μ F can be used.

VM (Pin 4/Pin 1): Voltage Monitor Input. High impedance input to an accurate comparator with a 0.5V threshold. Together with the WDE pin controls the state of the \overline{RST} output pin. Tie to device GND if voltage monitoring function is not used.

VS (Pin 17/Pin 14): Power Sense Input. This pin supplies power to the internal circuitry and is the cathode input to the ideal diode drivers (the anode inputs to the ideal diode drivers are the V1 and V2 pins). Bypass this pin to ground with one or more capacitors of at least 0.1 μ F.

WDE (Pin 6/Pin 3): Watchdog/Extend Input. A three-state input pin. A rising or falling edge must occur on this pin within a 1.6s watch-dog timeout period (while the \overline{RST} output is high impedance), to prevent the \overline{RST} pin from going low. The watchdog function of this pin is disabled when both of the ideal diode drivers are disabled in certain power path configurations (refer to the Application Information section). During a shutdown process: a rising or falling edge on this WDE pin within the 500ms $t_{KILL,OFF}$ period extends the waiting period another 500ms before the EN line is set low. This extend process can be repeated indefinitely in order to provide as much time as possible for the microprocessor to do its housekeeping functions before a power shut-down. Leave open or drive in high-Z state with a three-state buffer to disable watchdog or extend function or both.

BLOCK DIAGRAM

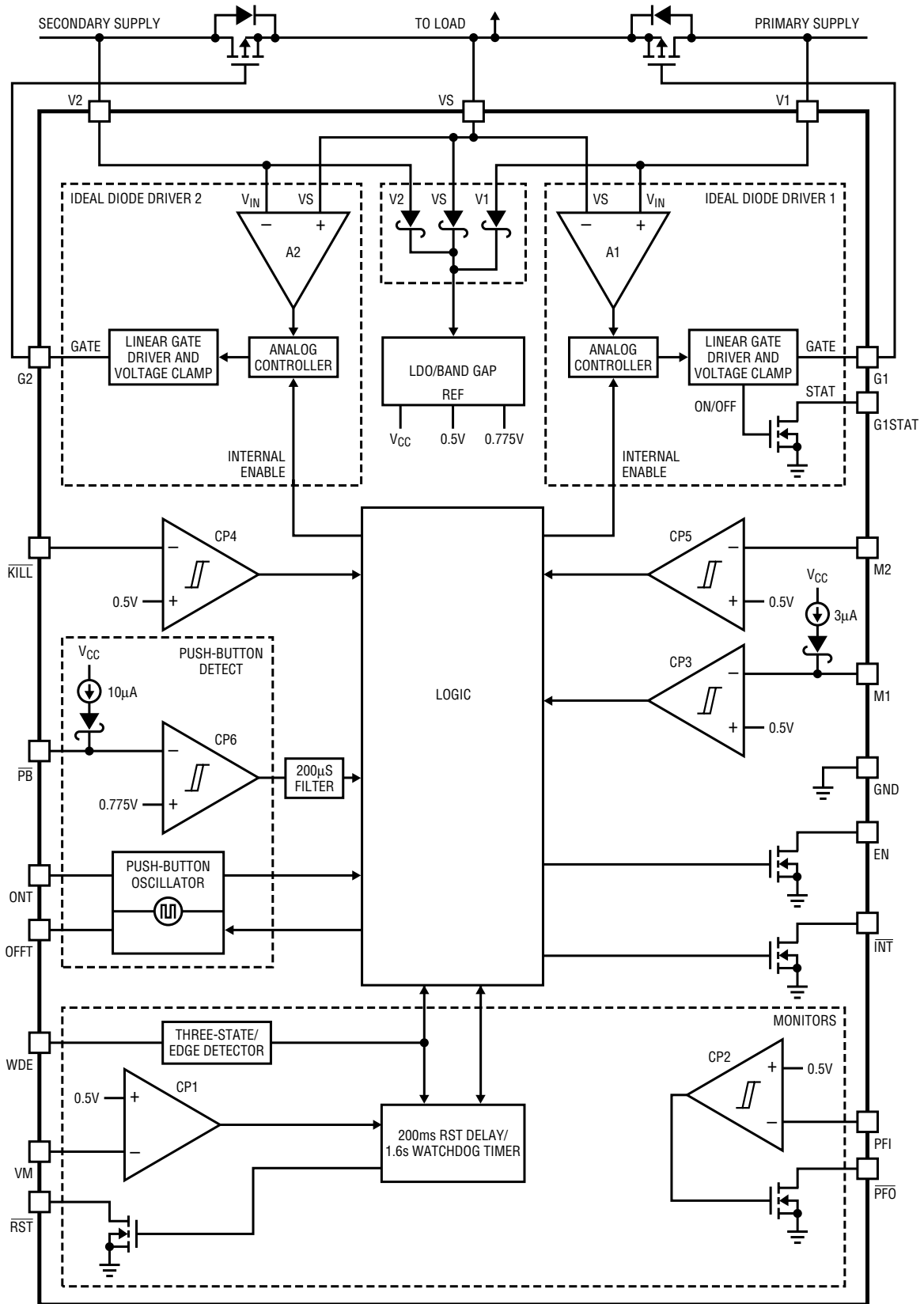

2952 BD

2952f

OPERATION

The LTC2952 is designed to simplify applications requiring management of multiple power sources. The three main features of the part are: push-button control, ideal diode power paths and system monitoring. The block diagram on the previous page shows the part divided into its main functional blocks.

The push-button detect block is responsible for debouncing any push-button event on the \overline{PB} pin. Note that the ON and OFF debounce times can be configured independently by using two separate capacitors on the ONT and OFFT pins respectively. A valid push-button on event will set the EN pin high impedance and a valid off event will drive the EN pin low.

In a typical application the EN pin is tied to the shutdown pin of a DC/DC converter. Therefore by toggling the EN pin, the push-button pin has a direct control over the enabling/disabling of an external DC/DC converter. This control of system turn-on/off is done in a graceful manner which ensures proper system power up and power down.

The ideal diode drivers regulate two external P-channel MOSFETs to achieve low loss switchover between two DC sources. Each driver regulates the gate of the PFET such that the voltage drop across its source and drain is 20mV. When the load current is larger than the PFET ability to deliver such current with a 20mV drop across its source and drain, the voltage at the gate clamps at $V_{G(ON)}$ and the PFET behaves like a fixed value resistor.

Besides providing ideal-diode power paths and control of system power turn-on/off, the LTC2952 also provides

system monitoring function via the VM, WDE, \overline{RST} and PFI, \overline{PFO} pins. The voltage monitoring (VM) and the watchdog (WDE) input pins determine the state of the \overline{RST} output with 200ms reset time and 1.6s watchdog time. The PFI and \overline{PFO} pins are the input and output of an accurate comparator that can be used as an early power fail monitor.

The \overline{KILL} , M1 and M2 pins are the inputs to accurate comparators with 0.5V threshold. The outputs of these comparators interact with the logic block to alter the ideal-diode power paths and the push-button control behavior. Specifically, the \overline{KILL} input provides the system with a capability to turn off system power at any point during operation. The M1 and M2 pins are mode pins that configure the part to have different behaviors in the power path switchover of the two DC sources.

Figure 1 shows the four different typical configurations of the LTC2952. In Configuration A, both of the ideal-diode power paths are always enabled which results in an automatic switchover between the two DC sources. Configuration C is similar to A except for the push-button input which now controls both the EN pin and the ideal diode power paths.

In Configurations B and D, M2 is used as a voltage monitor. In B, when the M2 input is above its threshold the primary ideal diode power path is disabled. In D, M2 needs to be above threshold before \overline{PB} has control over the EN pin and the ideal diode power paths. Furthermore in D, the rising and falling edges on M2 are interpreted as turn-on and turn-off commands respectively.

OPERATION

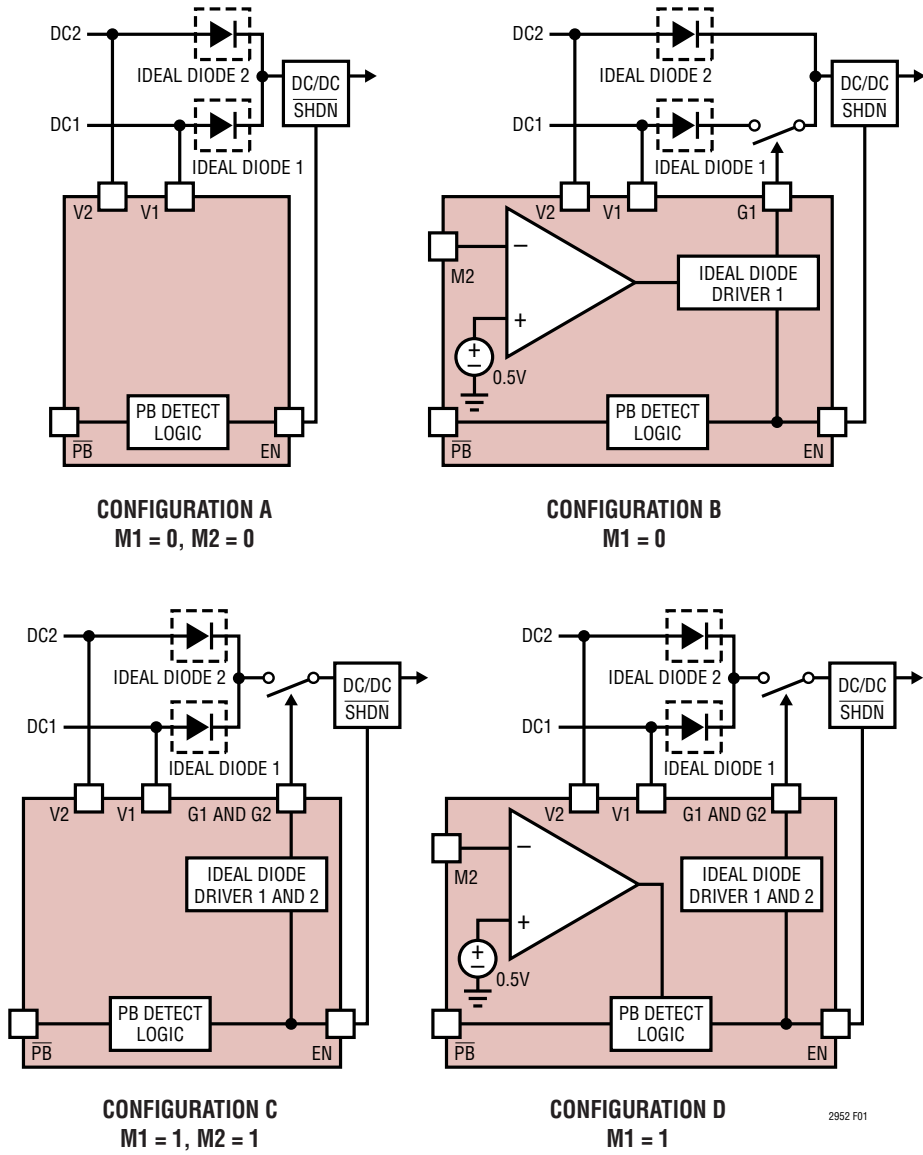

Figure 1. Four Different Typical Power Path Configurations

APPLICATIONS INFORMATION

The LTC2952 is a versatile power management IC with push-button on/off control and system supervisory features. The power management function features ideal diode power path control that provides low loss switchover between two DC sources. This power path control behavior is configurable to satisfy various application requirements.

The LTC2952’s push-button input has independently adjustable ON and OFF debounce times that control the toggling of a low-leakage open drain enable output and in some configurations, the ideal diode power path operation. A simple interface allows for digital on/off control and proper system housekeeping prior to power down.

The LTC2952 also features robust and accurate system supervisory functions that fit high reliability system applications. These supervisory functions include power-fail, voltage monitoring and watchdog reset functions which can be used to monitor power status and ensure system integrity.

The Ideal Diode Drivers

In a typical application, each of the ideal diode drivers is connected to drive an external P-channel MOSFET as shown in the Block Diagram and Figure 2. When power is available at V_{IN} and the ideal diode driver is enabled, the ideal diode driver regulates the voltage at the GATE to maintain a 20mV difference between V_{IN} and V_S . As the load current varies, the GATE voltage is controlled to maintain the 20mV difference.

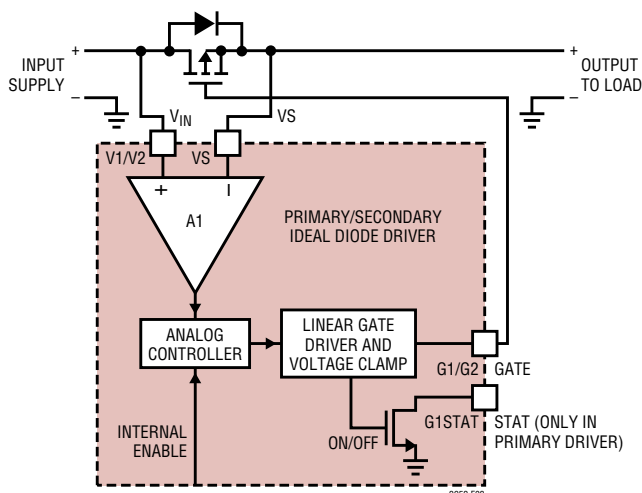

Figure 2. Detailed Ideal Diode Driver Functional Block Diagram

If the load current exceeds the external PFET’s ability to deliver the current with a 20mV V_{DS} , then the voltage at the GATE clamps and the PFET behaves as a fixed resistor causing the forward voltage to increase slightly as the load current increases. When the V_S pin is externally pulled up above the voltage level at V_{IN} , the ideal diode driver shuts the external PFET off to prevent reverse conduction. Thus when both the primary and secondary ideal diode drivers are enabled, the two ideal diode drivers work together to bring V_S to within 20mV of the higher of either V_1 or V_2 .

The G1STAT pin indicates the status of the primary ideal diode driver. If the external PFET connected to the primary driver is providing power to V_S , the G1STAT pin is in a high impedance state and when the PFET connected to the primary driver is shut-off, the G1STAT pin pulls low.

POWER PATH CONFIGURATIONS

Configuration A: Push-Button Controller with Automatic Switchover Between WALL Adapter and Battery

In this particular configuration both of the M1 and M2 pins are connected to ground. These connections set up the LTC2952 to operate with both of the ideal diodes enabled all the time.

In this application, power from the V_S node to the system is controlled through the EN pin connected to a shutdown

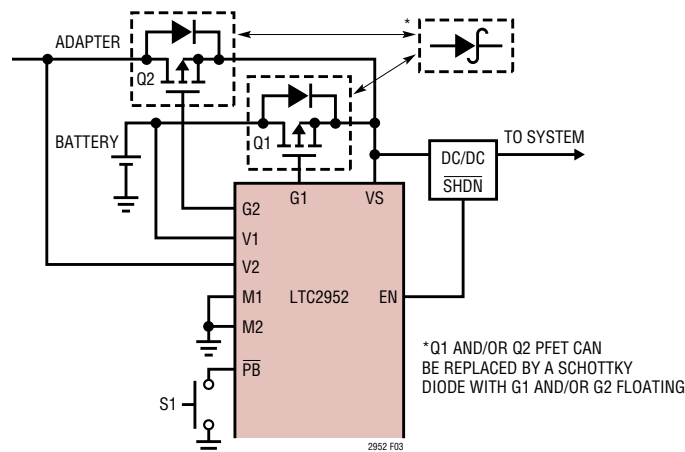

Figure 3. Power Path Configuration A

APPLICATIONS INFORMATION

pin of a DC/DC converter. The $\overline{\text{PB}}$ input achieves power path control by toggling this EN pin.

Note that in this application both of the ideal diodes are enabled all the time, therefore either Q1 or Q2 can be replaced by Schottky diodes as long as the voltage drop across the Schottky diodes and their reverse leakage currents are acceptable.

Configuration B: Push-Button Controller with Preferential WALL Adapter Operation and Automatic Switchover to Battery

In this configuration (Figure 4) the M1 pin is connected to ground and the M2 pin is used as a monitor on the Wall Adapter input to alter the behavior of the ideal diode drivers. When the Wall Adapter Voltage is below the trip threshold, both of the ideal diodes are enabled.

When the Wall Adapter Voltage is above the trip threshold, the primary ideal diode driver is disabled (shutting off Q1 and Q3) and the secondary ideal diode driver is enabled (turning on Q2). This means the load current will be supplied from the Wall Adapter (V2) regardless of the voltage level at the battery (V1).

If the wall Adapter Voltage trip threshold is set lower than the Battery input voltage level and the Wall Adapter input can go high impedance, the capacitance on V2 needs to be minimized. This is to ensure proper operation when the Wall Adapter goes high impedance and Q1, Q3 is instantly turned on.

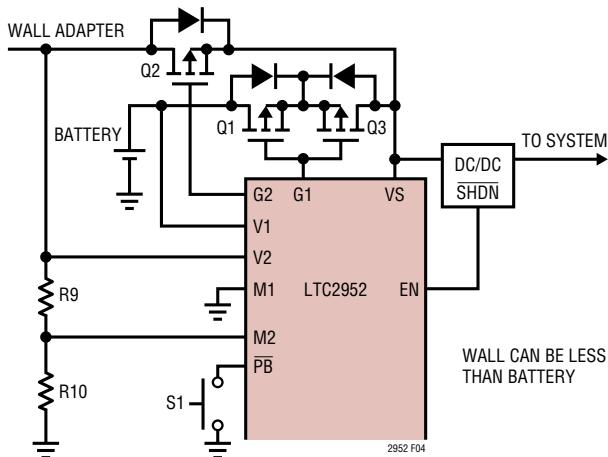

Figure 4. Power Path Configuration B

Noting the possible current path through the PFET body diode, a back-to-back PFET configuration must be used for Q1, Q3 to make sure that no current will flow from the battery (V1) to the VS pin even if the Wall Adapter (V2) Voltage is less than the battery (V1) Voltage.

Configuration C: Push-Button Control of Ideal Diode Drivers

In this configuration the M2 pin is tied to the M1 pin. Since the M1 pin has a $3\mu\text{A}$ internal pull-up current, this current causes both M1 and M2 to pull high. This allows the $\overline{\text{PB}}$ pin to have complete control of both the ideal diode drivers and the EN pin.

The first valid push-button input turns on both of the ideal diode drivers causing the VS pin to be driven to the higher of either the Wall Adapter or the Battery input – providing power to the system directly. Conversely, a valid push-button off input turns off the ideal diodes after the shutdown sequence involving an interrupt to the system.

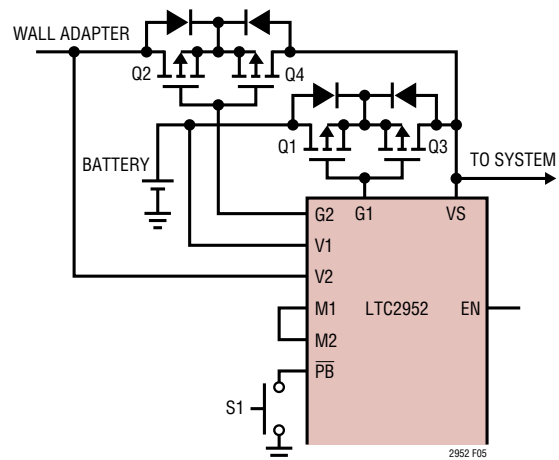

Figure 5. Power Path Configuration C

Configuration D: Battery Backup with Push-Button Power Path Controller

In this configuration shown in Figure 6, the M1 pin is left floating allowing its own $3\mu\text{A}$ internal pull-up to pull itself above threshold. With M1 high, the device operates such that rising and falling edges on the M2 pin are interpreted as digital on and off commands respectively.

In Figure 6, the M2 pin monitors the Wall Adapter Voltage. When power is first applied to the Wall Adapter so

APPLICATIONS INFORMATION

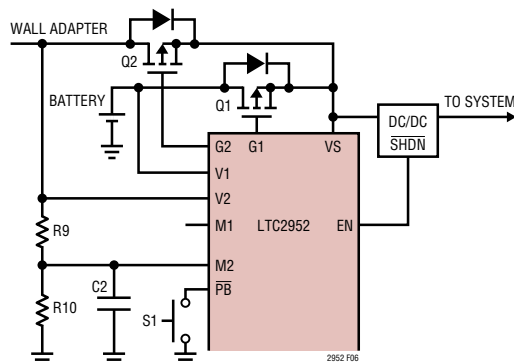

Figure 6. Power Path Configuration D

that the voltage at the M2 pin rises above its rising trip threshold (0.515V), both of the ideal diode drivers and the DC/DC converter are enabled. Thus power is delivered to the system.

As soon as the Wall Adapter voltage falls below its trip threshold, a shutdown sequence is immediately started. At the end of the shutdown sequence, the ideal diode drivers and the DC/DC converter are disabled. Thus power is cut off from the load and the system is in shutdown.

Note that once power is delivered to the system, the $\overline{\text{PB}}$ pin can be used to turn off the power. If $\overline{\text{PB}}$ is used to turn off the power in this configuration, there are two methods to turn the power back on: a valid push-button on event at the $\overline{\text{PB}}$ pin or a recycling of the Wall Adapter voltage (bringing the voltage level at the M2 pin down below and then back up above its threshold – a digital on command).

Also note that in this application, the voltage threshold of the Wall Adapter input (being monitored at the M2 pin) is usually set higher than the battery input voltage. Therefore, the only time when power is drawn from the battery (V1 pin) to the load is during the shutdown sequence when the voltage at the Wall adapter input (V2 pin) has collapsed below the battery input voltage level.

Reverse Battery Protection

To protect the LTC2952 from a reverse battery connection, place a 1k resistor in series with the respective supply pin intended for battery connection (V1 and/or V2) and remove any capacitance on the protected pin. Figure 7 shows a configuration with a reverse battery protection on the V1 pin. This resistor will limit the amount of current that flows

out of the V1 pin when a battery is connected in reverse and protect the part.

Note however, this reverse battery protection resistor should not be too large in value since the V1 and V2 pins are also used as the anode sense pins of the ideal diode drivers. When the ideal diode driver is on, the VS pin supplies most of the quiescent current of the part (60 μ A typ) and the supply pin supplies the remaining quiescent current (20 μ A typ). Therefore, the recommended 1k Ω reverse battery protection resistor amounts to an additional 20mV (1k Ω • 20 μ A) drop across the P-channel MOSFET.

In Figure 7, when the battery voltage is larger than the Wall Adapter voltage, the battery supplies the load current to the DC/DC converter. The ideal diode driver regulates G1 to maintain a fixed voltage drop from V1 to VS of 20mV (typ). Since there is a 20mV drop across the reverse battery protection resistor (R1) then the regulated voltage drop from the battery to the VS pin is 40mV (typ).

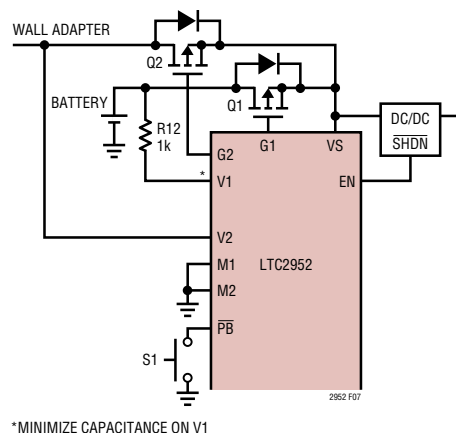

Figure 7. Reverse Battery Protection on V1

Push-Button Input and Circuitry

The $\overline{\text{PB}}$ pin is a high impedance input to an accurate comparator with a 10 μ A pull-up to an LDO regulated internal supply of 4V. The $\overline{\text{PB}}$ input comparator has a 0.775V falling trip threshold with 25mV hysteresis. Protection circuitry allows the $\overline{\text{PB}}$ pin to operate over wide range from –6V to 28V with an ESD HBM rating of \pm 8kV.

The push-button circuitry debounces the input into the $\overline{\text{PB}}$ pin that sets an internal ON/OFF signal. This signal initiates a turn ON/OFF power sequence.

APPLICATIONS INFORMATION

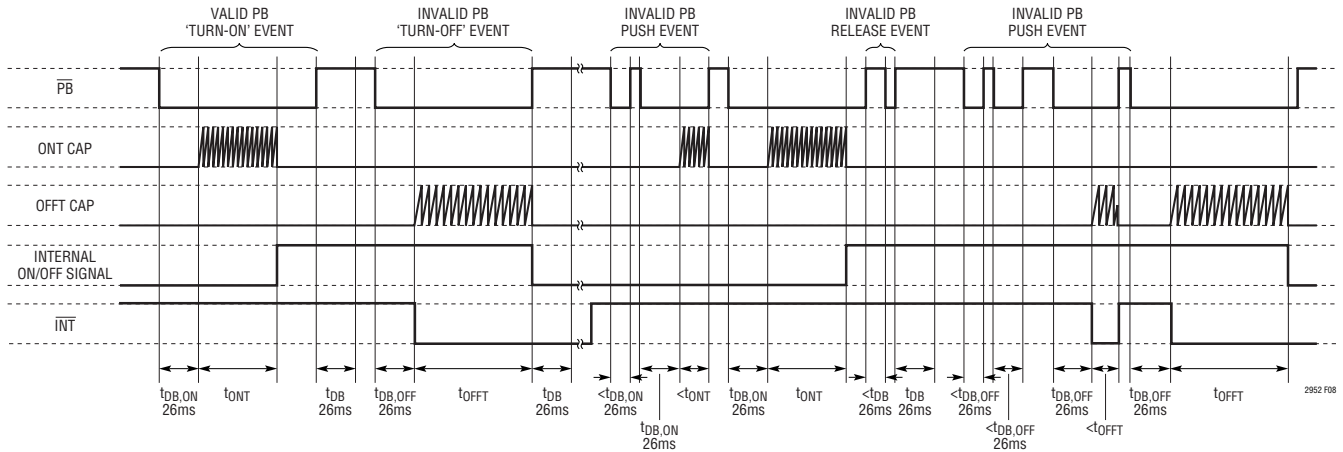

Figure 8. Push-Button Debounce Timing Diagram

The timing diagram in Figure 8 shows the \overline{PB} pin being debounced and setting an internal ON/OFF signal. Note that a high at the internal ON/OFF signal indicates that the last event was a turn-on command and a low at the internal ON/OFF signal indicates that the last event was a turn-off command. Here specifically the turn-on command is a result of a push-button on event and the turn-off command is a result of a push-button off event.

Note that a complete push-button consists of a push event and a release event. The push event (falling edge) on and off debounce durations on the \overline{PB} pin can be increased beyond the fixed internal 26ms by placing a capacitor on the ONT and OFFT pins respectively. The following equations describe the additional debounce time that a push event at the \overline{PB} pin must satisfy before it is recognized as a valid push-button on or off.

$$t_{ONT} = C_{ONT} \cdot (9.3M\Omega)$$

$$t_{OFFT} = C_{OFFT} \cdot (9.3M\Omega)$$

C_{ONT} and C_{OFFT} are the ONT and OFFT external programming capacitors respectively.

Note that during the push event of the push-button off, the \overline{INT} pin is asserted low after the initial 26ms debounce duration. The \overline{INT} pin asserts low when the \overline{PB} pin is held low during the OFFT debounce duration and during the shutdown sequence. If the \overline{PB} pin pulls high before the OFFT time ends, the \overline{INT} pin immediately turns high impedance. On the other hand, if the \overline{PB} pin is still held low at the end of the OFFT time, the \overline{INT} pin continues to assert low throughout the ensuing shutdown sequence.

On a release event (rising edge) of the push-button switch following a valid push event, the \overline{PB} pin must be continuously held above its rising threshold (0.8V) for a fixed 26ms internal debounce time.

In a typical application, the \overline{PB} pin is connected to a push-button switch. If the switch exhibits high leakage current ($>10\mu A$), connecting an external pull-up resistor to V_1 , V_2 and/or V_S (depending on the application) is recommended. Furthermore, if the push-button switch is physically located far from the LTC2952's \overline{PB} pin, signals may couple onto the high impedance \overline{PB} input. Placing a $0.1\mu F$ capacitor from the \overline{PB} pin to ground reduces the impact of signal coupling. Additionally, parasitic series inductance may cause undesirable ringing at the \overline{PB} pin. This can be minimized by placing a $5k\Omega$ resistor in series and located next to the switch.

Accurate Comparator Input Pins
VM, PFI, \overline{KILL} , M1 and M2

VM, PFI, \overline{KILL} , M1 and M2 are high impedance input pins to accurate comparators with a falling threshold of 0.500V.

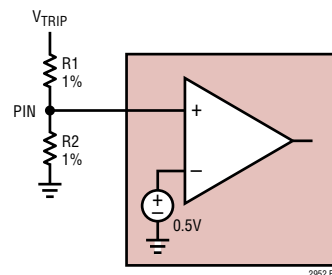

Figure 9. Setting the Comparator Trip Point

APPLICATIONS INFORMATION

Note the following differences between some of these pins: the VM pin comparator has no hysteresis while the other comparators have 15mV hysteresis and the M1 pin has a 3μA pull-up current while the other input pins do not.

Figure 9 shows the configuration of a typical application when VM, PFI, $\overline{\text{KILL}}$ or M2 pin connects to a tap point on an external resistive divider between a positive voltage and ground.

Calculate the falling trip voltage from the resistor divider value using:

$$V_{\text{FALLING-TRIP}} = 0.5V \left(1 + \frac{R1}{R2} \right)$$

Table 1 shows suggested 1% resistor values for various applications.

Table 1. Suggested 1% Resistor Values for the Accurate Comparators (–6.5% nominal threshold)

| V _{SUPPLY} (V) | V _{TRIP} (V) | R1 (kΩ) | R2 (kΩ) |
|----------------------------|--------------------------|------------|------------|
| 12 | 11.25 | 2150 | 100 |
| 10 | 9.4 | 1780 | 100 |
| 8 | 7.5 | 1400 | 100 |
| 7.5 | 7 | 1300 | 100 |
| 6 | 5.6 | 1020 | 100 |
| 5 | 4.725 | 845 | 100 |
| 3.3 | 3.055 | 511 | 100 |
| 3 | 2.82 | 464 | 100 |
| 2.5 | 2.325 | 365 | 100 |
| 1.8 | 1.685 | 237 | 100 |
| 1.5 | 1.410 | 182 | 100 |
| 1.2 | 1.120 | 124 | 100 |
| 1.0 | 0.933 | 86.6 | 100 |
| 0.9 | 0.840 | 68.1 | 100 |
| 0.8 | 0.750 | 49.9 | 100 |
| 0.7 | 0.655 | 30.9 | 100 |
| 0.6 | 0.561 | 12.1 | 100 |

In a typical application the M1 pin is usually either connected to ground or left floating. When left floating, the internal 3μA pull-up drives the M1 pin high above its rising threshold (0.515V). Note that this 3μA pull-up current can be used to pull up any or all of the other

high impedance input pins. For example, connect the M2 pin to the M1 pin to pull both up above their rising thresholds as shown in Figure 5.

The Voltage Monitor and Watchdog Function

The first voltage monitor input is PFI. As mentioned before, this pin is a high impedance input to an accurate comparator with 15mV hysteresis. When the voltage at PFI is higher than its rising threshold (0.515V), the $\overline{\text{PFO}}$ pin is high impedance. Conversely, when the voltage level at PFI is lower than its falling threshold (0.500V), the $\overline{\text{PFO}}$ pin strongly pulls down to GND.

The second voltage monitor input is VM. The VM pin together with the WDE pin (acting as a watchdog monitor pin) affects the state of the $\overline{\text{RST}}$ output pin. The VM pin is also a high impedance input to an accurate comparator. However, the VM comparator has no hysteresis and hence the same rising and falling threshold (0.500V).

When the voltage level at VM is less than 0.5V, the $\overline{\text{RST}}$ pin strongly pulls down to GND. When the voltage level at VM first rises above 0.5V, the $\overline{\text{RST}}$ output pin is held low for another 200ms (t_{RST}) before turning high impedance.

After the $\overline{\text{RST}}$ pin becomes high impedance, if the WDE input pin is not left in a high-Z state, the watchdog timer is started. The watchdog timer is reset every time there is an edge (high to low or low to high transition) on the WDE pin. The watchdog timer can expire due to any of the following conditions:

1. No valid edge on the WDE pin in a t_{WDE} (1.6s) time period after the $\overline{\text{RST}}$ pin transitions from pulling low to high impedance.
2. No valid edge on the WDE pin in a t_{WDE} (1.6s) time period since the last valid edge on the WDE pin while the $\overline{\text{RST}}$ pin is high impedance.

As shown in the timing diagrams section, when the watchdog timer is allowed to expire while voltage at the VM pin is higher than 0.5V, the $\overline{\text{RST}}$ pin strongly pulls down to ground for t_{RST} (200ms) before again becoming high impedance for t_{WDE} (1.6s). This will continue unless there is an edge at the WDE pin, the voltage at VM goes below 0.5V, or the watchdog function is disabled (by leaving the WDE in a High-Z state).

APPLICATIONS INFORMATION

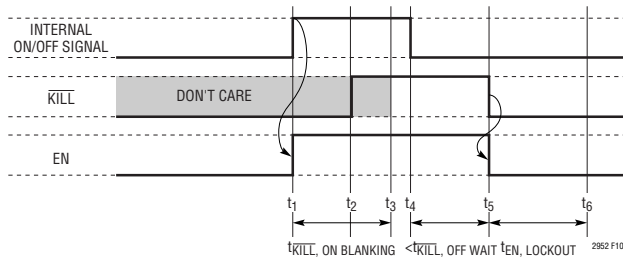

Figure 10. Power-On and Power-Off Sequence with $\overline{\text{KILL}}$ Deasserting EN During $\overline{\text{KILL}}$ Off Wait Time

In certain power path configurations where both of the ideal diode drivers are disabled, the watchdog function of the WDE pin is also disabled. Examples of such configurations are configuration C (Figure 5) and configuration D (Figure 6) when both of the ideal diode can be turned off due to a valid push button off or a digital off command.

Power-On/Power-Off Sequence

Figure 10 shows a normal power-on and power-off timing diagram. Note that in this timing diagram only the clean internal ON/OFF signal is shown. A transition at this internal ON/OFF signal can be caused by a valid debounced push-button ON/OFF or a digital ON/OFF through the mode input pins (M1/M2).

In this timing sequence, the $\overline{\text{KILL}}$ pin has been set low since power is first applied to the LTC2952. As soon as the internal ON/OFF signal transitions high (t_1), the EN pin goes high impedance and an internal 500ms ($t_{\text{KILL, ON BLANK}}$) timer starts. During this 500ms $\overline{\text{KILL}}$ On Blanking period, the input to $\overline{\text{KILL}}$ pin is ignored and the EN pin remains in its high impedance state. This $\overline{\text{KILL}}$ On Blanking period is designed to give the system sufficient time to power up properly.

Once the $\mu\text{P}/\text{system}$ powers on, it sets the $\overline{\text{KILL}}$ pin high (t_2) indicating that proper power-up sequence is completed. Failure to set $\overline{\text{KILL}}$ pin high at the end of the 500ms $\overline{\text{KILL}}$ on blanking time (t_3) will result in immediate system shut down (see Aborted Power-On Sequence segment). After the $\overline{\text{KILL}}$ On Blanking time expires, the system is now in normal operation with power turned on.

When the internal ON/OFF signal transitions low (t_4), a shut down sequence is immediately started. From the start of the shutdown sequence the system power will turn off in 500ms ($t_{\text{KILL, OFF WAIT}}$), unless an edge (a high-to-low or

low-to-high transition) at the WDE pin is detected within the 500ms period to extend the wait period for another 500ms.

This $\overline{\text{KILL}}$ Off Wait time (500ms/cycle) is designed to allow the system to finish performing its housekeeping tasks before shutdown. Once the μP finishes performing its power-down operations, it can either let the 500ms $\overline{\text{KILL}}$ Off Wait time expire on its own or set the $\overline{\text{KILL}}$ pin low (t_5) immediately terminating the $\overline{\text{KILL}}$ Off Wait time. When the $\overline{\text{KILL}}$ Off Wait time expires, the LTC2952 sets EN low, turning off the DC/DC converter connected to the EN pin.

When the DC/DC converter is turned off (EN goes low), it can take a significant amount of time for its output level to decay to ground. In order to guarantee that the μP has always powered down properly before it is re-started, another 500ms (Enable Lock Out time, $t_{\text{EN, LOCKOUT}}$) timer is started to allow for the DC/DC converter output power level to power down completely to ground. During this Enable Lock Out time, the EN pin remains in its low state.

At the end of the 500ms Enable Lock Out time (t_6), the LTC2952 goes into its reset state with the EN pin remains strongly pulling down.

Aborted Power-On Sequence

The power-on sequence is aborted when the μP fails to set $\overline{\text{KILL}}$ pin high before the 500ms $\overline{\text{KILL}}$ On Blanking time expires as shown in the timing diagram in Figure 11. When the $\overline{\text{KILL}}$ On Blanking timer expires (t_7), the $\overline{\text{KILL}}$ pin is still low indicating that the $\mu\text{P}/\text{system}$ has failed to power on successfully. When the system failed to set $\overline{\text{KILL}}$ pin high within the specified 500ms time window, the LTC2952 pulls the EN pin low (thus turning off the DC/DC converter) and as a side effect resets the internal ON/OFF signal.

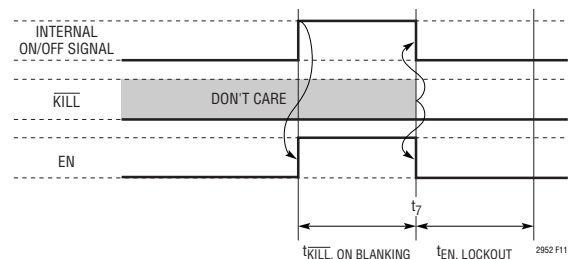

Figure 11. Aborted Power-On Sequence

APPLICATIONS INFORMATION

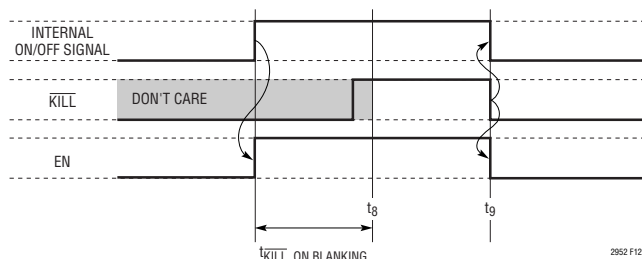

Figure 12. $\overline{\text{KILL}}$ Initiated Shutdown

$\overline{\text{KILL}}$ Power Turn-Off During Normal Operation

Once the system has powered on and is operating normally, the system can turn off power by setting $\overline{\text{KILL}}$ low as shown in the timing diagram in Figure 12. At t_9 , $\overline{\text{KILL}}$ is set low and this immediately causes the LTC2952 to pull EN low, turning off the DC/DC converter.

Extended Power During Turn-Off

In the shutdown process, the availability of power can be extended by providing edges to the WDE pin during the $\overline{\text{KILL}}$ Off Wait time. The timing diagram in Figure 13 is similar to the power-on/power-off sequence timing diagram (Figure 10) except for the edges on the WDE pin during the shutdown process. At time t_{10} , the internal ON/OFF signal transitions low. When this happens, the DC/DC converter providing power to the system will be shut off in 500ms unless the WDE pin is toggled.

When the WDE pin transitions at t_{11} , the LTC2952 resets the 500ms $\overline{\text{KILL}}$ Off Wait timer. Before this second 500ms

wait time expires, the WDE pin transitions again (this time from high to low) at t_{12} , causing the 500ms timer to reset again. Finally, the third 500ms timer which starts at t_{12} expires without any further extension at t_{13} causing the EN pin to go low, shutting down the DC/DC converter.

Setting Up Different Configurations

The various configurations discussed previously are summarized here in Table 2, including the ideal diode power paths state (ID1-primary, ID2-secondary). Note that an input above 0.515V (typical rising threshold) on the M1 and M2 pins is indicated with a 1 and an input below 0.500V (typical falling threshold) is represented by a 0. Also, an enabled ideal diode driver is indicated with a 1 and a disabled driver is indicated with a 0.

Table 2. Mode Table

| Mode | Description | M1 | M2 | EN | ID1 | ID2 |
|------|---|----|----|----|-----|-----|
| 0 | Both Diodes Enabled | 0 | 0 | 0 | 1 | 1 |
| 1 | Both Diodes Enabled | 0 | 0 | 1 | 1 | 1 |
| 2 | Primary Diode Off, Secondary Diode On | 0 | 1 | 0 | 0 | 1 |
| 3 | Primary Diode Off, Secondary Diode On | 0 | 1 | 1 | 0 | 1 |
| 4 | Power Path Off, PB Overwrite | 1 | 0 | 0 | 0 | 0 |
| 5 | Transitional Power Path Off, PB Overwrite | 1 | 0 | 1 | 1 | 1 |
| 6 | Push-Button Power Path Off | 1 | 1 | 0 | 0 | 0 |
| 7 | Push-Button Power Path On | 1 | 1 | 1 | 1 | 1 |

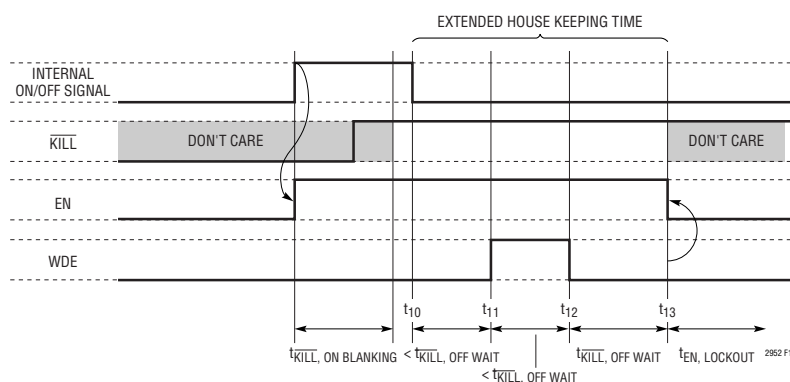

Figure 13. Power-On/Power-Off Sequence with Extended Shutdown/Housekeeping Wait Time

APPLICATIONS INFORMATION

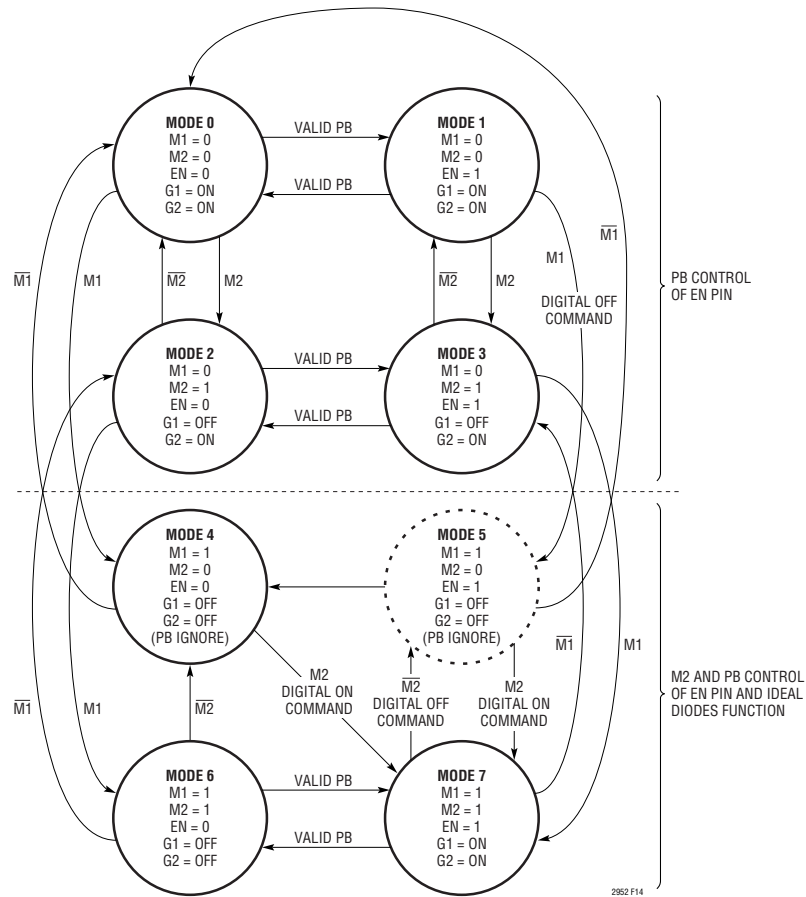

Figure 14. Mode Transition Diagram

In addition to the mode table, the mode transition diagram in Figure 14 shows all possible interactions between the events on the pins (\overline{PB} , M1 and M2) and the different modes of the LTC2952 power path behavior. Using Table 2 and Figure 14, it is possible to configure the LTC2952 in many different ways beyond the four discussed in the Operation and Applications Information sections.

In modes 0 and 1, both of the ideal diode drivers are enabled all the time. A valid push-button toggles the mode between 0 and 1 (changing the state of the EN pin) without ever turning off of the ideal diodes. These modes are used in Configuration A and B (Figures 3 and 4).

In modes 2 and 3, only V2 provides power to the load connected at VS because the primary ideal diode driver is disabled and only the secondary ideal diode driver

is enabled. These modes are used in Configuration B (Figure 4).

In modes 4 and 5 both of the ideal diodes are disabled and the input to the PB pin is ignored. Note that mode 5 is a transitional mode. If there is no change at the M1 and M2 pin while in mode 5, the mode eventually transitions into mode 4 after a proper shutdown sequence.

A rising edge at M1 in mode 1 or a falling edge at M2 in mode 7 is recognized as a digital off command, which causes a transition to mode 5. When a digital off command is received, the EN pin is driven low and the ideal diodes are disabled after a proper shutdown sequence involving the interrupt alert to the μP (\overline{INT} pin driven low) – refer to the earlier sections for details on the shutdown sequence.

APPLICATIONS INFORMATION

Note that since the PB input is ignored in both mode 4 and 5, the only way to turn on the power path from these two modes is a transition from 0 to 1 at the M2 pin. A transition from 0 to 1 at the M2 pin in modes 4 or 5 is interpreted as a digital on command. This digital on command causes the mode to transition from mode 4 or 5 to mode 7. In mode 7, both of the ideal diodes are enabled and the EN pin goes high impedance. Modes 4, 5 and 7 are used in Configuration D (Figure 6).

Notice that in mode 7, both the M2 pin and the $\overline{\text{PB}}$ pin have direct control over the EN pin. A transition from 1 to 0 at the M2 pin in mode 7 is recognized as a digital off command. This digital off command causes a transition to

mode 4 after a proper shutdown sequence. On the other hand, a valid push-button off mode 7 transitions the part to mode 6 after a proper shutdown sequence. In both mode 4 and mode 6 the EN pin is driven low. Modes 6 and 7 are used in Configuration C (Figure 5).

In mode 4 the ideal diode driver circuitry is disabled, the EN pin is driven low, and the PB input is ignored. On the other hand in mode 6, although both of the primary and secondary ideal diodes are disabled and the EN pin is set low, the PB input is not ignored. A valid push-button transitions the part from mode 6 to mode 7 turning on both the ideal diodes and setting the EN pin high impedance (turning on the DC/DC converter).

TYPICAL APPLICATIONS

Wall Adapter and Battery Automatic Load Switchover with Simple On/Off Push-Button Control and Voltage Monitors for System Power Without μP

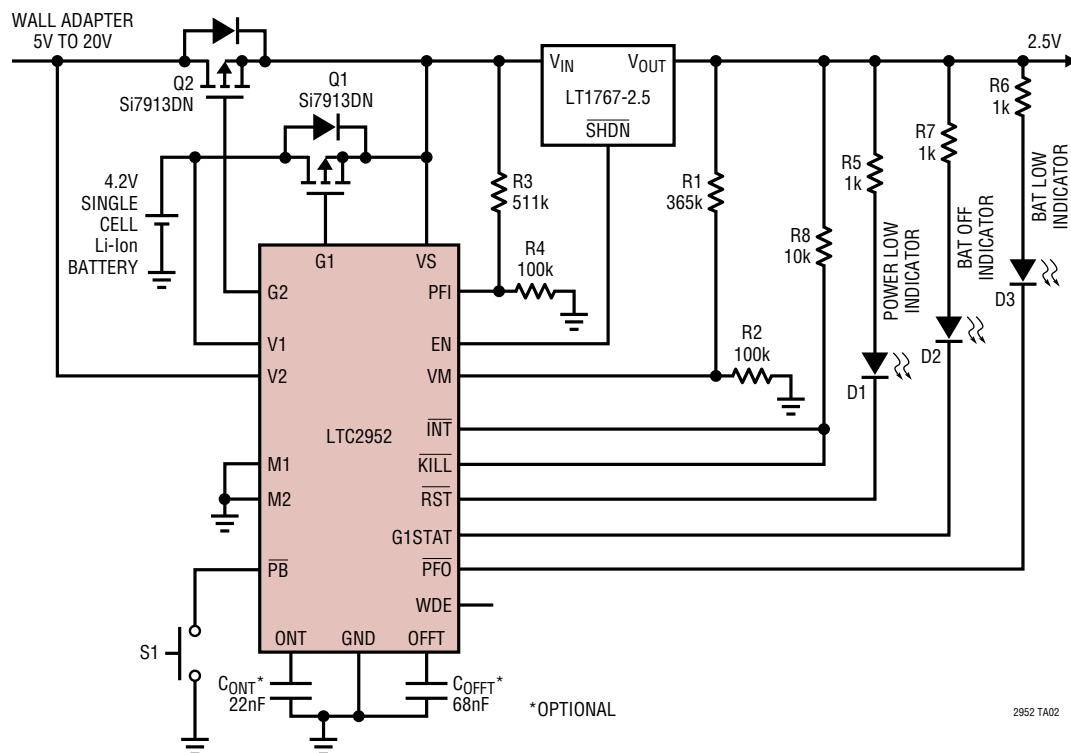

2952 TA02

TYPICAL APPLICATIONS

Wall Adapter and Battery Automatic Load Switchover with Push-Button Control, Voltage Monitors and Watchdog

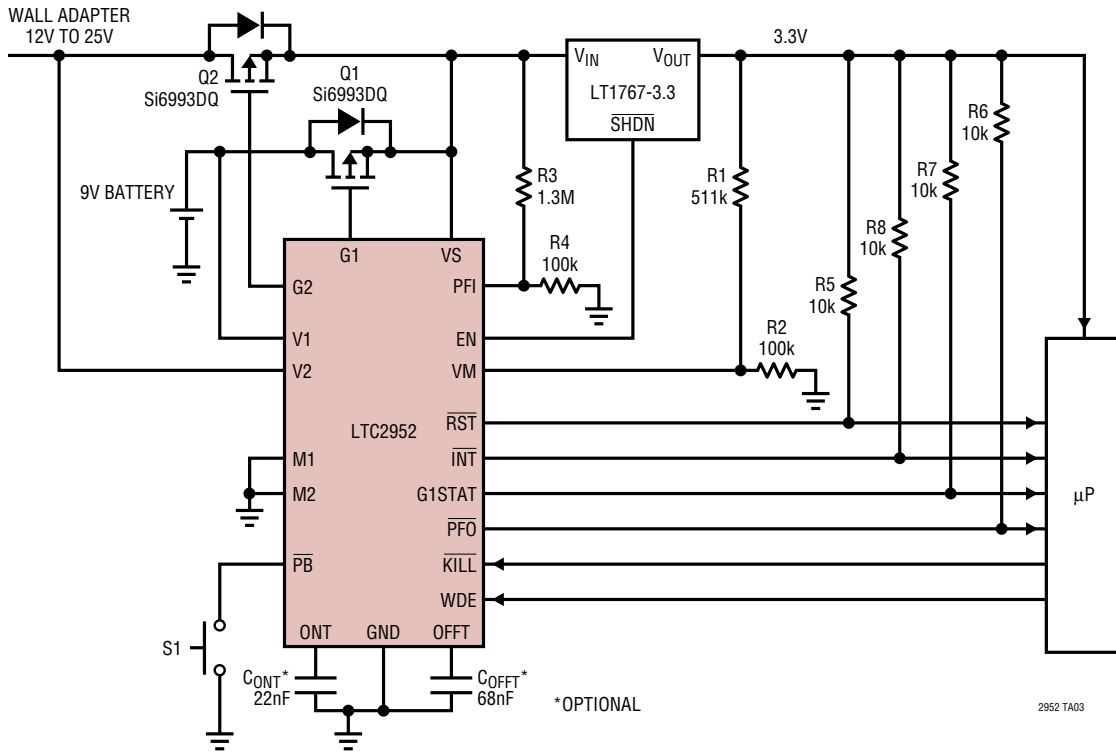

Uninterruptible Power Supply with Preferential Wall Adapter Operation and Automatic Load Switchover to Battery with Push-Button Control, Voltage Monitors and Watchdog

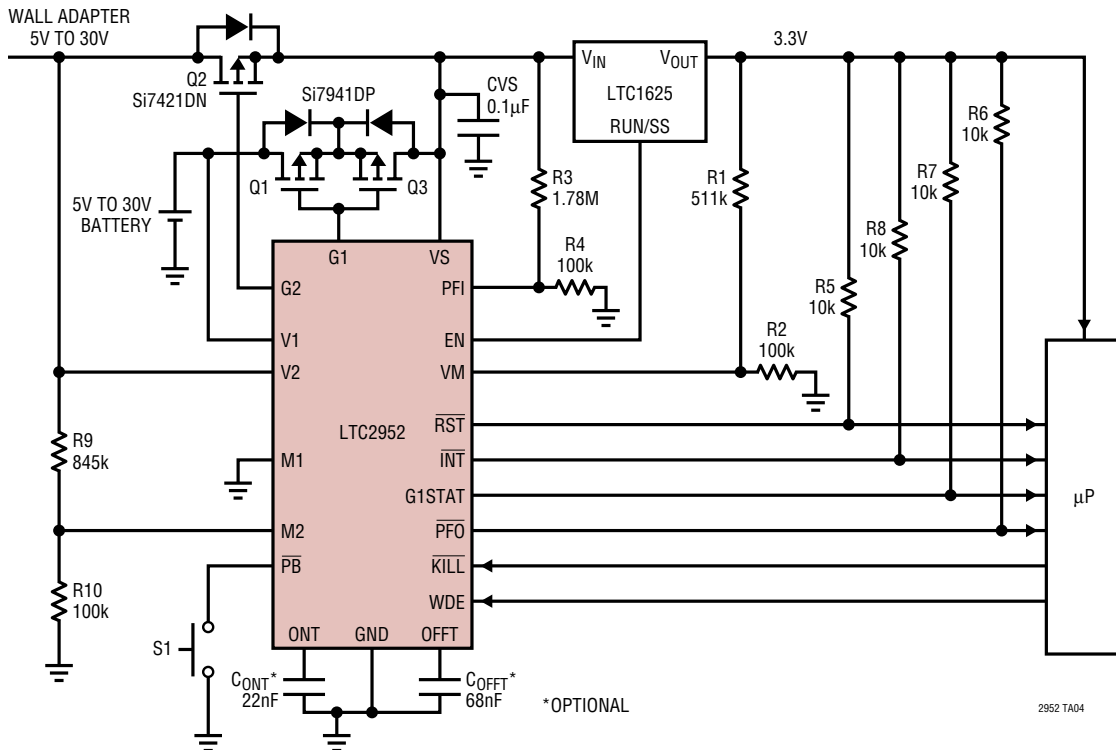

TYPICAL APPLICATIONS

Direct Power Path Control with Push-Button Control, Voltage Monitors and Watchdog

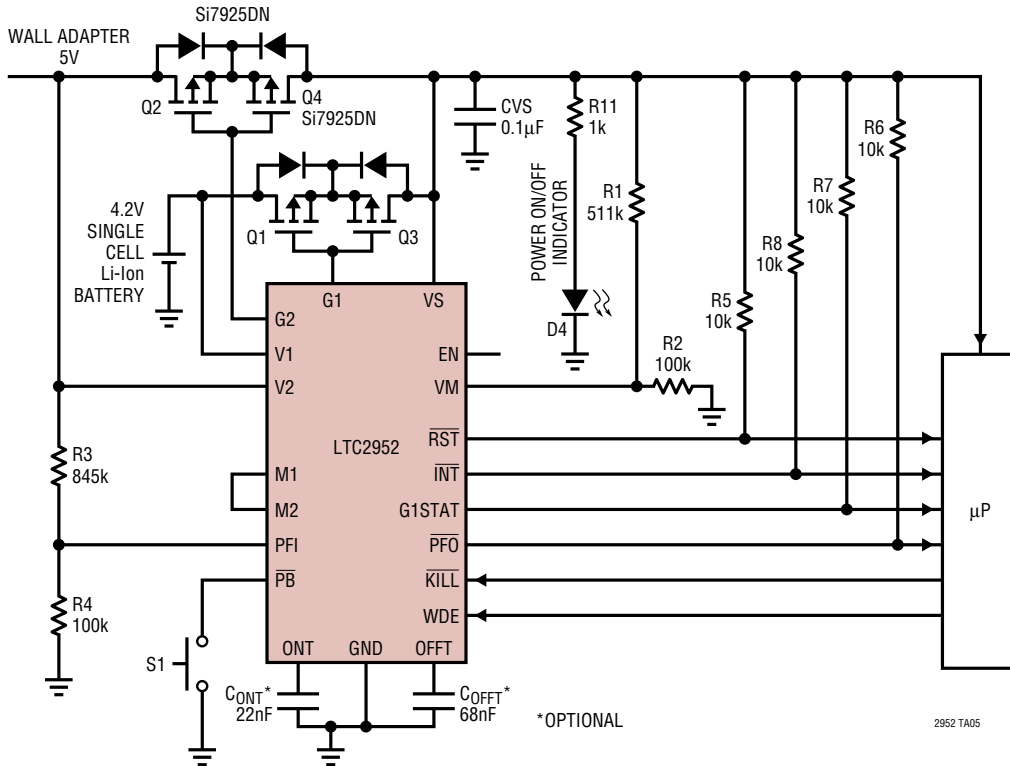

Critical System with Primary Supply and Temporary Battery Backup with Push-Button Control, Voltage Monitors and Watchdog

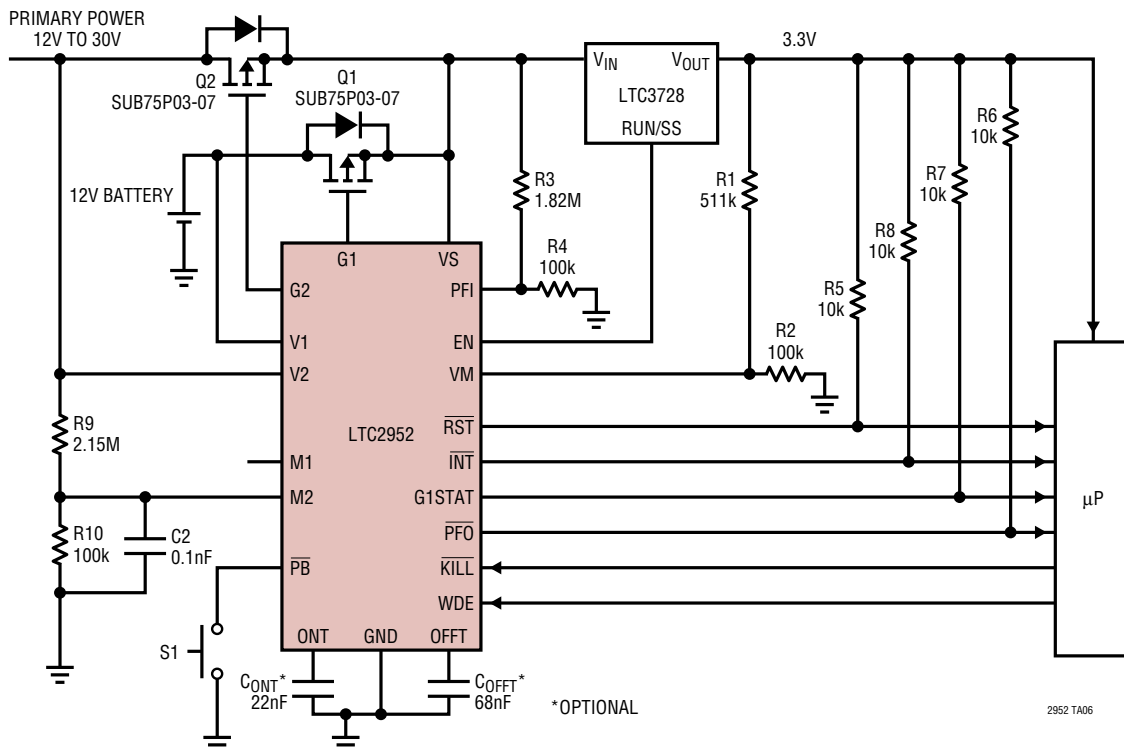

PACKAGE DESCRIPTION

F Package
20-Lead Plastic TSSOP (4.4mm)
 (Reference LTC DWG # 05-08-1650)

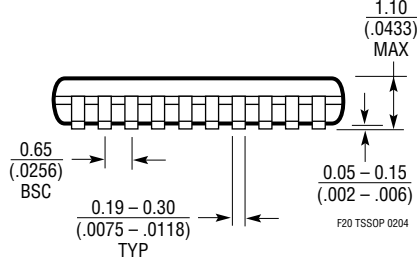
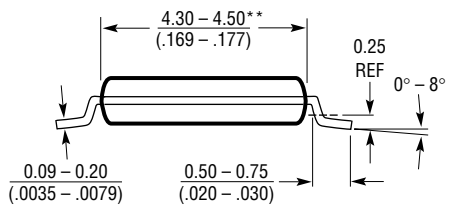
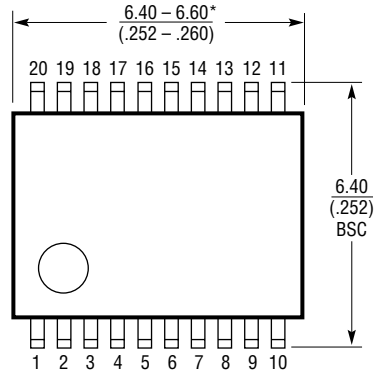
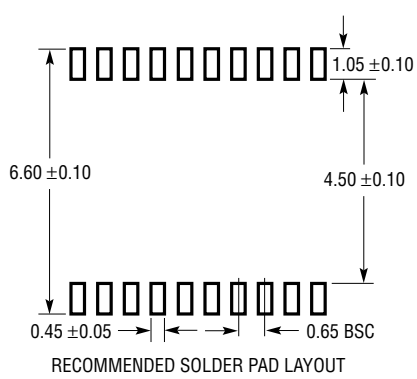

- NOTE:
1. CONTROLLING DIMENSION: MILLIMETERS
 2. DIMENSIONS ARE IN $\frac{\text{MILLIMETERS}}{\text{INCHES}}$
 3. DRAWING NOT TO SCALE
- *DIMENSIONS DO NOT INCLUDE MOLD FLASH. MOLD FLASH SHALL NOT EXCEED .152mm (.006") PER SIDE
- **DIMENSIONS DO NOT INCLUDE INTERLEAD FLASH. INTERLEAD FLASH SHALL NOT EXCEED .254mm (.010") PER SIDE

PACKAGE DESCRIPTION

UF Package 20-Lead Plastic QFN (4mm × 4mm) (Reference LTC DWG # 05-08-1710)

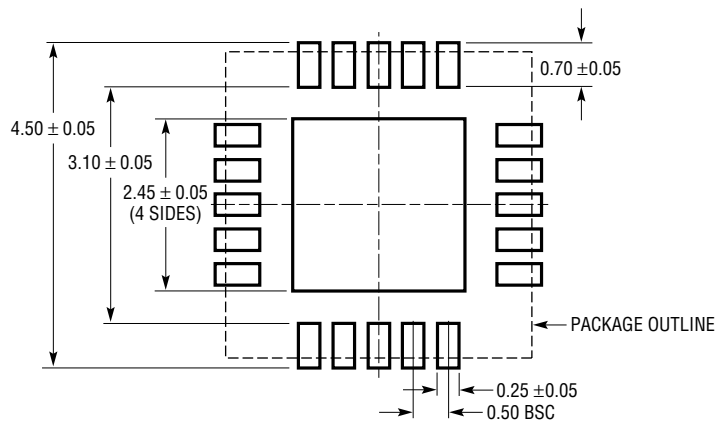

RECOMMENDED SOLDER PAD PITCH AND DIMENSIONS

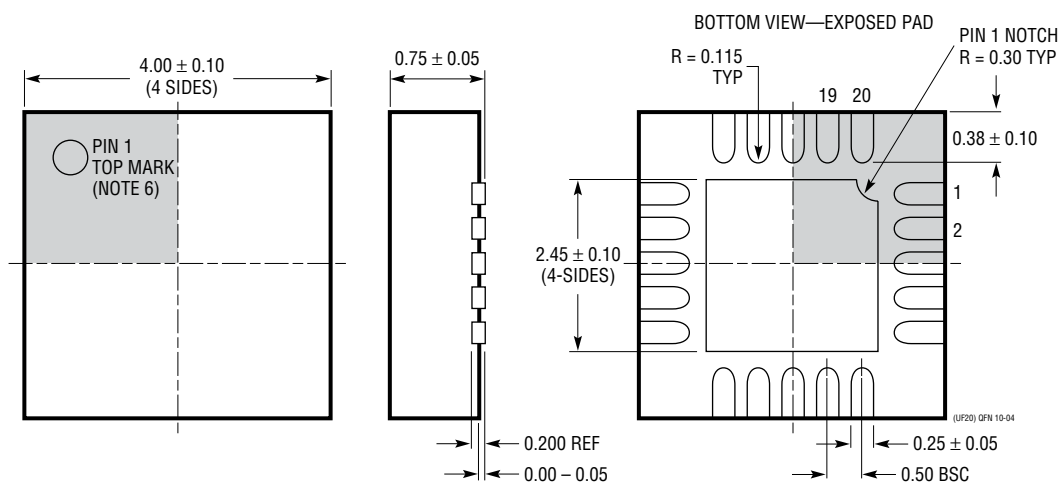

- NOTE:
1. DRAWING IS PROPOSED TO BE MADE A JEDEC PACKAGE OUTLINE MO-220 VARIATION (WGGD-1)—TO BE APPROVED
 2. DRAWING NOT TO SCALE
 3. ALL DIMENSIONS ARE IN MILLIMETERS
 4. DIMENSIONS OF EXPOSED PAD ON BOTTOM OF PACKAGE DO NOT INCLUDE MOLD FLASH. MOLD FLASH, IF PRESENT, SHALL NOT EXCEED 0.15mm ON ANY SIDE
 5. EXPOSED PAD SHALL BE SOLDER PLATED
 6. SHADED AREA IS ONLY A REFERENCE FOR PIN 1 LOCATION ON THE TOP AND BOTTOM OF PACKAGE

TYPICAL APPLICATION

Wall Adapter and Battery Automatic Load Switchover with Reverse Battery Protection

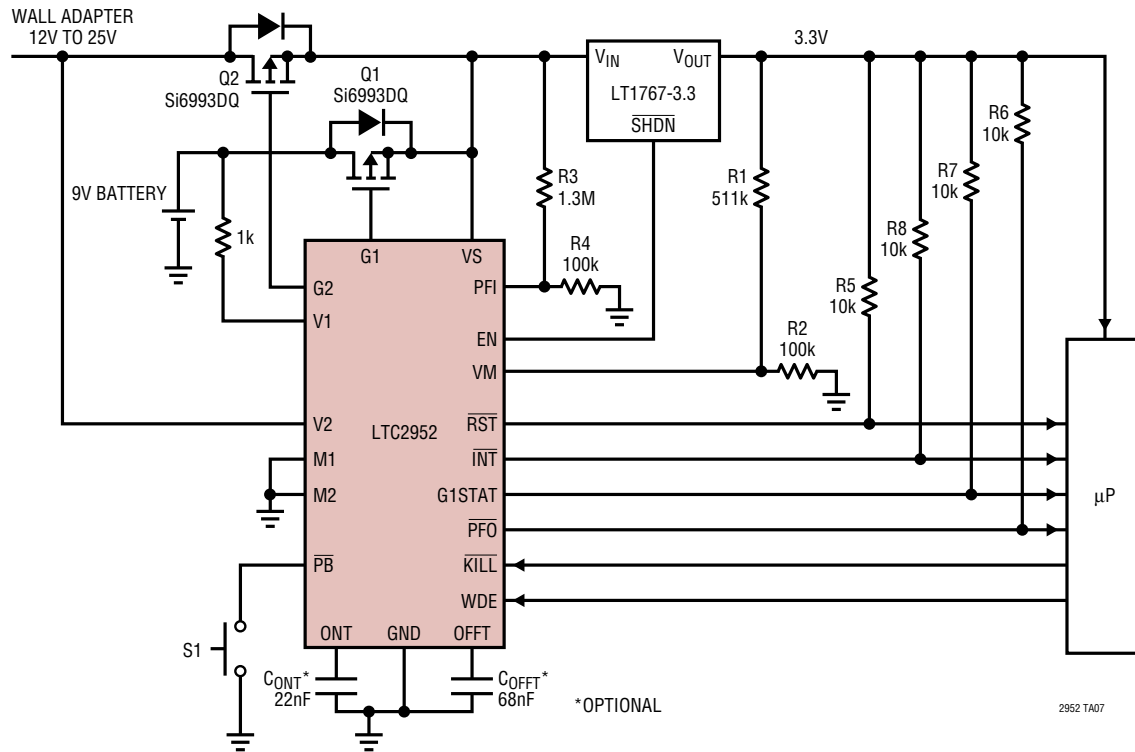

2952 TA07

RELATED PARTS

| PART NUMBER | DESCRIPTION | COMMENTS |
|---------------------|--|---|
| LTC1479 | PowerPath Controller for Dual Battery Systems | Complete PowerPath Management for Two Batteries; DC Power Source, Charger and Backup |
| LTC1726 | Micropower Triple Supply Monitor for 2.5V/5V, 3.3V and ADJ | Adjustable RESET and Watchdog Time-Outs |
| LTC2900 | Programmable Quad Supply Monitor | Adjustable RESET, 10-Lead MSOP and DFN Packages |
| LTC2901 | Programmable Quad Supply Monitor | Adjustable RESET and Watchdog Timer, 16-Lead SSOP Package |
| LTC2902 | Programmable Quad Supply Monitor | Adjustable RESET and Tolerance, 16-Lead SSOP Package |
| LTC2903 | Precision Quad Supply Monitor | 6-Lead SOT-23 Package |
| LTC2904/ LTC2905 | Three-State Programmable Precision Dual Supply Monitor | Adjustable Tolerance, 8-Lead SOT-23 and DFN Packages |
| LTC2906/ LTC2907 | Dual Supply Monitor with One Pin Selectable Threshold and One Adjustable Input | 0.5V Adjustable Threshold and Three Supply Tolerances, 8-Lead SOT-23 and DFN Packages |
| LTC2908 | Precision Six Supply Monitors | 0.5V Adjustable Threshold, RESET, 8-Lead SOT-23 and DFN Packages |
| LTC2950/ LTC2951 | Push-Button On/Off Controller | μP Push-Button Controller Interface with Programmable Debounce On and Off Timing, 8-Lead SOT23 and DFN Packages |
| LTC4411 | SOT-23 Ideal Diode | 2.6A Forward Current, 28mV Regulated Forward Voltage |
| LTC4412HV | PowerPath Controller in ThinSOT | Efficient Diode-ORing, Automatic Switching, 3V to 36V |

PowerPath is a trademark of Linear Technology Corporation.