

## Features

- Low Insertion Loss, 1.2 dB Typical
- Fast Switching Speed, 4 nS Typical
- Ultra Low DC Power Consumption
- Terminated Option
- RoHS\* Compliant

## Description

M/A-COM's MASW4060G is an SPDT absorptive or reflective GaAs MESFET MMIC. This part combines small size, low insertion loss and power consumption with high isolation. Ideal for many applications and module use. It will function well for designs below 4.0 GHz.

The MASW4060G is fabricated using a mature 1-micron gate length GaAs MESFET process. The process features full chip passivation for increased performance and reliability.

## Ordering Information

Part Number	Package
MASW4060G	DIE <sup>1</sup>

1. Die quantity varies.

## Schematic

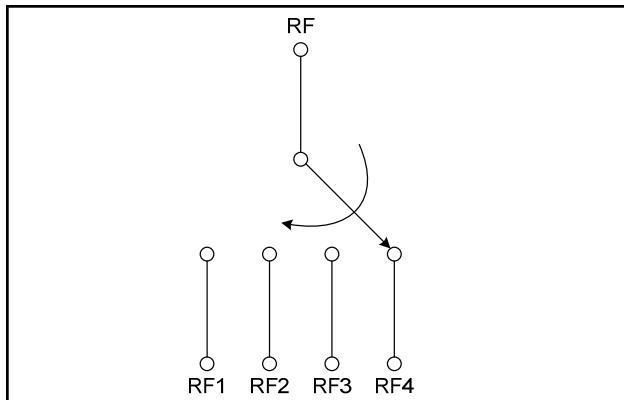

\* Restrictions on Hazardous Substances, European Union Directive 2002/95/EC.

## Pad Layout

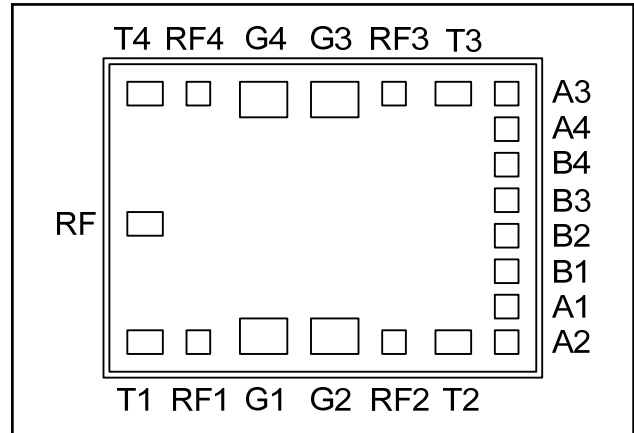

## Die Size - Inches (mm)

0.076 x 0.058 x 0.010 (1.920 x 1.470 x 0.25)

## Absolute Maximum Rating<sup>2,3</sup>

Parameter	Absolute Maximum
Control Value (A or B)	-8.5 Vdc
Max Input RF Power	+34 dBm
Storage Temperature	-65°C to +175°C
Max Operating Temperature	+175°C

2. Exceeding any one or combination of these limits may cause permanent damage to this device.
3. M/A-COM does not recommend sustained operation near these survivability limits.

## Bond Pad Dimensions

Bond Pad	Dimensions - Inches (mm)
RF	0.005 x 0.005 (0.125 x 0.125)
RF1, RF2, RF3, RF4	0.004 x 0.004 (0.100 x 0.100)
A1, A2, A3, A4	0.004 x 0.004 (0.100 x 0.100)
B1, B2, B3, B4	0.004 x 0.004 (0.100 x 0.100)
G1, G2, G3, G4 <sup>4</sup>	0.008 x 0.004 (0.200 x 0.100)
T1, T2, T3, T4 <sup>5</sup>	0.006 x 0.005 (0.150 x 0.125)

4. "G" pads designate internal grounds necessary to maintain data sheet isolation. These are not DC blocked and would need to be blocked if positive control voltage is required.
5. "T" pads denote a 50 Ω termination path connected to each RFx port. If bonded to ground, it will cause the related port to be absorptive, or matched, in the isolated condition. As described in note 4, these pads are also not DC blocked.

## GaAs SP4T Switch DC - 4.0 GHz

Rev. V4

### Electrical Specifications: 0/-5 Vdc, 50 Ω, -55°C to +85°C <sup>6</sup>

Parameter	Test Conditions	Units	Min.	Typ.	Max.
Insertion Loss	DC - 0.5 GHz	dB	—	—	1.3
	DC - 1.0 GHz	dB	—	—	1.3
	DC - 2.0 GHz	dB	—	—	1.3
	DC - 4.0 GHz	dB	—	—	1.7
Isolation	DC - 0.5 GHz	dB	50	—	—
	DC - 1.0 GHz	dB	45	—	—
	DC - 2.0 GHz	dB	40	—	—
	DC - 4.0 GHz	dB	30	—	—
VSWR	DC - 0.5 GHz	Ratio	—	—	1.4:1
	DC - 1.0 GHz	Ratio	—	—	1.4:1
	DC - 2.0 GHz	Ratio	—	—	1.5:1
	DC - 4.0 GHz	Ratio	—	—	2.0:1
Input P-1dB	0.5 GHz	dBm	—	+17	—
	0.5 - 4.0 GHz	dBm	—	+27	—
IP2	Two Tone Input Power up to +5 dBm 0.5 GHz	dBm	—	+45	—
	0.5 - 4.0 GHz	dBm	—	+60	—
IP3	Two Tone Input Power up to +5 dBm 0.5 GHz	dBm	—	+35	—
	0.5 - 4.0 GHz	dBm	—	+46	—
Control Current	V <sub>IN</sub> Low (0 to -0.2 V)	μA	—	—	25
	V <sub>OUT</sub> High (-5 V)	μA	—	50	200
T-rise, T-fall	10% to 90% RF and 90% to 10% RF	nS	—	2	—
T <sub>ON</sub> , T <sub>OFF</sub>	50% control to 90% RF, and 50% control to 10% RF	nS	—	4	—
Transients	In Band	mV	—	20	—

6. Loss changes ±0.0025 dB/°C. (From -55°C to +85°C)

### Truth Table <sup>7</sup>

A1	B1	A2	B2	A3	B3	A4	B4	ANT-RF1	ANT-RF2	ANT-RF3	ANT-RF4
1	0	0	1	0	1	0	1	On	Off	Off	Off
0	1	1	0	0	1	0	1	Off	On	Off	Off
0	1	0	1	1	0	0	1	Off	Off	On	Off
0	1	0	1	0	1	1	0	Off	Off	Off	On

7. 0 = 0 V to -0.2 V, 1 = -5 V.

### Handling Procedures

Please observe the following precautions to avoid damage:

#### Static Sensitivity

Gallium Arsenide Integrated Circuits are sensitive to electrostatic discharge (ESD) and can be damaged by static electricity. Proper ESD control techniques should be used when handling these devices.

### Wire Bonding

- Ball or wedge with 1.0 mil diameter pure gold wire. Thermosonic wirebonding with a nominal stage temperature of 150°C and a ball bonding force of 40 to 50 grams or wedge bonding force of 18 to 22 grams is recommended. Ultrasonic energy and time should be adjusted to the minimum levels achieve reliable wirebonds.
- Wirebonds should be started on the chip and terminated on the package. GND bonds should be as short as possible; at least three and no more than four bond wires from ground pads to package are recommended.

## Typical Performance @ 25°C

### Insertion Loss

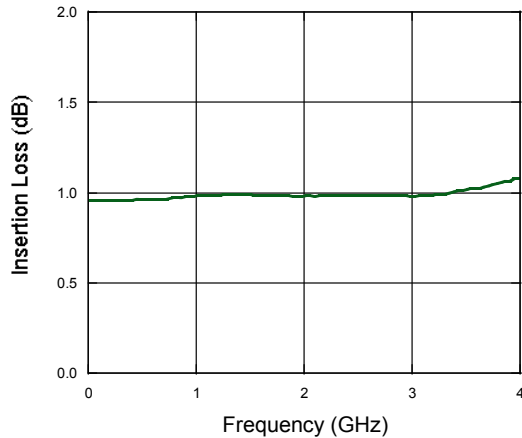

### Isolation

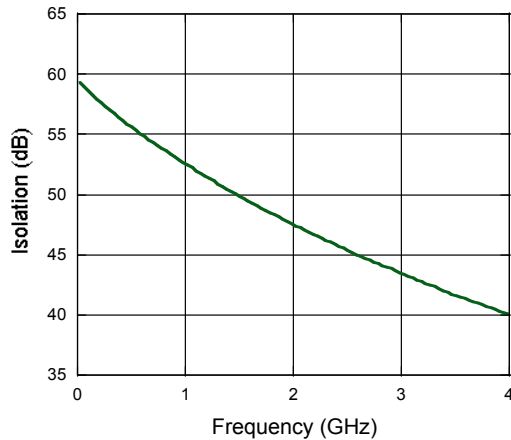

### VSWR

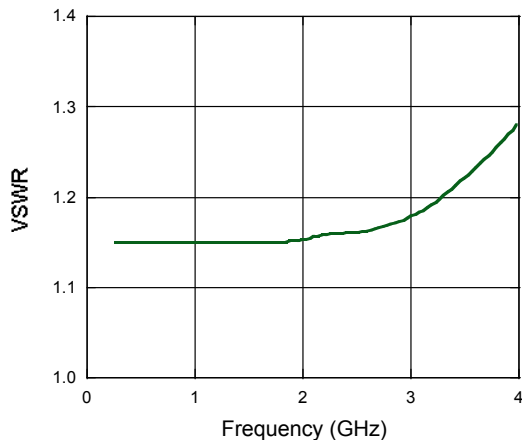

## Handling Precautions

Permanent damage to the MASW4060 may occur if the following precautions are not adhered to:

- A. Cleanliness - The MASW4060 should be handled in a clean environment. DO NOT attempt to clean unit after MASW4060 is installed.
- B. Static Sensitivity - All chip handling equipment and personnel should be DC grounded.
- C. Transient - Avoid instrument and power supply transients while bias is applied to the MASW4060. Use shielded signal and bias cables to minimize inductive pick-up.
- D. Bias - Apply voltage to either control port V1 or V2 only when the other is grounded. No port should be allowed to "float."
- E. General Handling - It is recommended that the MASW4060 chip be handled along the long side of the die with a sharp pair of bent tweezers. DO NOT touch the surface of the chip with fingers or tweezers.

## Mounting

The MASW4060 is back-metallized with Pd/Ni/Au (100/1,000/10,000Å) metallization. It can be die-mounted with AuSn eutectic performs or with thermally conductive epoxy. The package surface should be clean and flat before attachment.

### Eutectic Die Attach:

- A. A 80/20 gold/tin perform is recommended with a work surface temperature or approximately 225°C and a tool temperature of 265°C. When hot 90/10 nitrogen/hydrogen gas is applied, tool tip temperature should be approximately 290°C.
- B. DO NOT expose the MASW4060 to a temperature greater than 320°C for more than 20 seconds. No more than 3 seconds of scrubbing should be required for attachment.

### Epoxy Die Attach:

- A. Apply a minimum amount of epoxy and place the MASW4060 into position. A thin epoxy fillet should be visible around the perimeter of the chip.
- B. Cure epoxy per manufacturer's recommended schedule.
- C. Electrically conductive epoxy may be used but is not required.