

Product Specification

RoHS-6 Compliant

SONET/SDH 10Gb/s DWDM XFP Optical Transceiver

FTLX3812S3xx

PRODUCT FEATURES

- Supports 9.95Gb/s and 10.7Gb/s
- Hot-pluggable XFP footprint
- Temperature-stabilized DWDM EML transmitter
- RoHS-6 Compliant (lead-free)
- 100GHz ITU Grid, C-Band
- Duplex LC connector
- Power dissipation <3.5W
- Built-in digital diagnostic functions
- Temperature range: -5°C to 70°C



APPLICATIONS

- Amplified DWDM 10G SONET/SDH

Finisar's FTLX3812S3xx Small Form Factor 10Gb/s (XFP) transceiver complies with the current XFP Multi-Source Agreement (MSA) Specification¹. It supports amplified DWDM 10Gb/s SONET/SDH applications. Digital diagnostics functions are available via a 2-wire serial interface, as specified in the XFP MSA. For a multiprotocol version that supports 10G Ethernet, please see FTLX3812M3xx. The transceiver is RoHS compliant and lead free per Directive 2002/95/EC³, and Finisar Application Note AN-2038⁴.

PRODUCT SELECTION

FTLX3812S3xx

xx: 100GHz ITU-T channel
(see next page)

Channel #	Product Code	Frequency (THz)	Center Wavelength (nm)
17*	FTLX3812S317	191.7	1563.86
18*	FTLX3812S318	191.8	1563.05
19*	FTLX3812S319	191.9	1562.23
20*	FTLX3812S320	192.0	1561.42
21	FTLX3812S321	192.1	1560.61
22	FTLX3812S322	192.2	1559.79
23	FTLX3812S323	192.3	1558.98
24	FTLX3812S324	192.4	1558.17
25	FTLX3812S325	192.5	1557.36
26	FTLX3812S326	192.6	1556.55
27	FTLX3812S327	192.7	1555.75
28	FTLX3812S328	192.8	1554.94
29	FTLX3812S329	192.9	1554.13
30	FTLX3812S330	193.0	1553.33
31	FTLX3812S331	193.1	1552.52
32	FTLX3812S332	193.2	1551.72
33	FTLX3812S333	193.3	1550.92
34	FTLX3812S334	193.4	1550.12
35	FTLX3812S335	193.5	1549.32
36	FTLX3812S336	193.6	1548.51
37	FTLX3812S337	193.7	1547.72
38	FTLX3812S338	193.8	1546.92
39	FTLX3812S339	193.9	1546.12
40	FTLX3812S340	194.0	1545.32
41	FTLX3812S341	194.1	1544.53
42	FTLX3812S342	194.2	1543.73
43	FTLX3812S343	194.3	1542.94
44	FTLX3812S344	194.4	1542.14
45	FTLX3812S345	194.5	1541.35
46	FTLX3812S346	194.6	1540.56
47	FTLX3812S347	194.7	1539.77
48	FTLX3812S348	194.8	1538.98
49	FTLX3812S349	194.9	1538.19
50	FTLX3812S350	195.0	1537.40
51	FTLX3812S351	195.1	1536.61
52	FTLX3812S352	195.2	1535.82
53	FTLX3812S353	195.3	1535.04
54	FTLX3812S354	195.4	1534.25
55	FTLX3812S355	195.5	1533.47
56	FTLX3812S356	195.6	1532.68
57	FTLX3812S357	195.7	1531.90
58	FTLX3812S358	195.8	1531.12
59	FTLX3812S359	195.9	1530.33
60*	FTLX3812S360	196.0	1529.55
61*	FTLX3812S361	196.1	1528.77

*This channel is supported with limited availability -- Please contact Finisar for further details.

I. Pin Descriptions

Pin	Logic	Symbol	Name/Description	Ref.
1		GND	Module Ground	1
2		VEE5	Optional –5.2 Power Supply – Not required	
3	LVTTL-I	Mod-Desel	Module De-select; When held low allows the module to respond to 2-wire serial interface commands	
4	LVTTL-O	Interrupt	Interrupt (bar); Indicates presence of an important condition which can be read over the serial 2-wire interface	2
5	LVTTL-I	TX_DIS	Transmitter Disable; Transmitter laser source turned off	
6		VCC5	+5 Power Supply	
7		GND	Module Ground	1
8		VCC3	+3.3V Power Supply	
9		VCC3	+3.3V Power Supply	
10	LVTTL-I	SCL	Serial 2-wire interface clock	2
11	LVTTL-I/O	SDA	Serial 2-wire interface data line	2
12	LVTTL-O	Mod_Abs	Module Absent; Indicates module is not present. Grounded in the module.	2
13	LVTTL-O	Mod_NR	Module Not Ready; Finisar defines it as a logical OR between RX_LOS and Loss of Lock in TX/RX.	2
14	LVTTL-O	RX_LOS	Receiver Loss of Signal indicator	2
15		GND	Module Ground	1
16		GND	Module Ground	1
17	CML-O	RD-	Receiver inverted data output	
18	CML-O	RD+	Receiver non-inverted data output	
19		GND	Module Ground	1
20		VCC2	+1.8V Power Supply	
21	LVTTL-I	P_Down/RST	Power Down; When high, places the module in the low power stand-by mode and on the falling edge of P_Down initiates a module reset Reset; The falling edge initiates a complete reset of the module including the 2-wire serial interface, equivalent to a power cycle.	
22		VCC2	+1.8V Power Supply	
23		GND	Module Ground	1
24	PECL-I	RefCLK+	Reference Clock non-inverted input, AC coupled on the host board – Not required	
25	PECL-I	RefCLK-	Reference Clock inverted input, AC coupled on the host board – Not required	
26		GND	Module Ground	1
27		GND	Module Ground	1
28	CML-I	TD-	Transmitter inverted data input	
29	CML-I	TD+	Transmitter non-inverted data input	
30		GND	Module Ground	1

Notes:

1. Module circuit ground is isolated from module chassis ground within the module.
2. Open collector; should be pulled up with 4.7k – 10kohms on host board to a voltage between 3.15V and 3.6V.

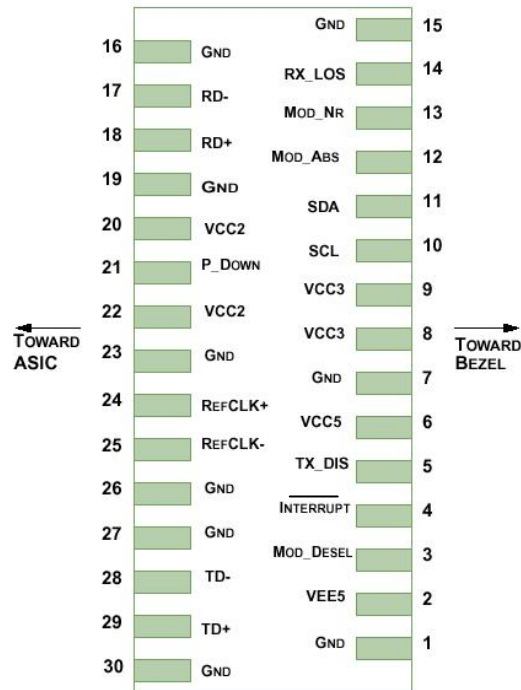

Diagram of Host Board Connector Block Pin Numbers and Names

II. Absolute Maximum Ratings

Parameter	Symbol	Min	Typ	Max	Unit	Ref.
Maximum Supply Voltage #1	Vcc3	-0.5		4.0	V	
Maximum Supply Voltage #2	Vcc5	-0.5		6.0	V	
Maximum Supply Voltage #3	Vcc5	-0.5		2.0	V	
Storage Temperature	T _S	-40		85	°C	
Case Operating Temperature	T _{OP}	-5		70	°C	
Receiver Damage Threshold	P _{Rdmg}	+1			dBm	

III. Electrical Characteristics ($T_{OP} = -5$ to 70 °C, $V_{CC5} = 4.75$ to 5.25 Volts)

Parameter	Symbol	Min	Typ	Max	Unit	Ref.	
Supply Voltage #1	Vcc5	4.75		5.25	V		
Supply Voltage #2	Vcc3	3.13		3.46	V		
Supply Voltage #3	Vcc2	1.71		1.89	V		
Supply Current – Vcc5 supply	Icc5			350	mA		
Supply Current – Vcc3 supply	Icc3			400	mA		
Supply Current – Vcc2 supply	Icc2			750	mA		
Module total power	P			3.5	W	1	
Transmitter							
Input differential impedance	R _{in}		100		Ω	2	
Differential data input swing	V _{in,pp}	120		820	mV		
Transmit Disable Voltage	V _D	2.0		V _{cc}	V	3	
Transmit Enable Voltage	V _{EN}	GND		GND+ 0.8	V		
Transmit Disable Assert Time				10	us		
Receiver							
Differential data output swing	V _{out,pp}	340	650	850	mV	4	
Data output rise time	t _r			38	ps	5	
Data output fall time	t _f			38	ps	5	
LOS Fault	V _{LOS fault}	V _{cc} – 0.5		V _{ccHOST}	V	6	
LOS Normal	V _{LOS norm}	GND		GND+0.5	V	6	
Power Supply Rejection	PSR	See Note 6 below					7
Reference Clock							
Clock differential input impedance	R _{clk,in}		100		Ω		
Reference Clock frequency	f ₀		Baud/64		MHz		
Differential clock input swing	V _{clk,pp}	640		1600	mV		
Clock output rise/fall time	t _{rf}	200		1250	ps	5	
Reference clock frequency tolerance	Df	-100		+100	PPM		

Notes:

1. Maximum total power value is specified across the full temperature and voltage range.
2. After internal AC coupling.
3. Or open circuit.
4. Into 100 ohms differential termination.
5. 20 – 80 %
6. Loss Of Signal is open collector to be pulled up with a 4.7k – 10kohm resistor to 3.15 – 3.6V. Logic 0 indicates normal operation; logic 1 indicates no signal detected.
7. Per Section 2.7.1. in the XFP MSA Specification¹.

IV. Optical Characteristics (EOL, $T_{OP} = -5$ to $70^{\circ}C$, $V_{CC5} = 4.75$ to 5.25 Volts)

Please note that the Transmitter of the FTLX3811S3xx becomes operational within 60 seconds of power-up. This is due to the time required for the EML to reach its optimum operating temperature.

Transmitter						
Parameter	Symbol	Min	Typ	Max	Unit	Ref.
Output Opt. Pwr: 9/125 SMF	P_{OUT}	-3		+3	dBm	
Optical Extinction Ratio	ER	8.2			dB	
Center Wavelength Spacing			100		GHz	1
Transmitter Center Wavelength – End Of Life	λ_C	X-100	X	X+100	pm	2
Transmitter Center Wavelength – Beginning Of Life	λ_C	X-25	X	X+25	pm	2
Sidemode Suppression ratio	SSR_{min}	30			dB	
Tx Jitter Generation (peak-to-peak)	T_{Xj}			0.1	UI	3
Tx Jitter Generation (RMS)	T_{XjRMS}			0.01	UI	4
Relative Intensity Noise	RIN			-130	dB/Hz	
Receiver						
Maximum Input Power	P_{MAX}	-7			dBm	
Optical Center Wavelength	λ_C	1270		1600	nm	
Receiver Reflectance	R_{rx}			-27	dB	
LOS De-Assert	LOS_D			-30	dBm	
LOS Assert	LOS_A	-35			dBm	
LOS Hysteresis		0.5			dB	
Receiver Sensitivity						5
Data rate (Gb/s)	BER	Dispersion (ps/nm)	Sensitivity back-to-back at OSNR>30dB (dBm)	Power Penalty at OSNR>30dB (dB)	Threshold Adjustm. Required	
9.95	1e-12	-500 to 1450	-23	3	No	
10.7	1e-4	-500 to 1300	-27	3	Yes	
OSNR Performance						6
Data rate (Gb/s)	BER	Dispersion (ps/nm)	Min OSNR Back-to-back at Power: -7 to -18dBm (dB)	Max OSNR Penalty at Power:-7 to -18dBm (dB)	Threshold Adjustm. Required	
9.95	1e-12	-500 to 1450	24	4	No	
10.7	1e-4	-500 to 1300	16	4	Yes	

Notes:

1. Corresponds to approximately 0.8 nm.
2. X = Specified ITU Grid wavelength. Wavelength stability is achieved within 60 seconds of power up.
3. Measured with a host jitter of 50 mUI peak-to-peak.
4. Measured with a host jitter of 7 mUI RMS.
5. Measured at 1528-1600nm with worst ER; BER< 10^{-12} ; PRBS31.
6. All OSNR measurements are performed with 0.1nm resolution.

V. General Specifications

Parameter	Symbol	Min	Typ	Max	Units	Ref.
Bit Rate	BR	9.95		10.7	Gb/s	1
Max. Supported Link Length	L _{MAX}		80		km	

Notes:

1. Amplified SONET OC-192, SONET OC-192 with FEC.

VI. Environmental Specifications

Finisar XFP transceivers have an operating temperature range from -5°C to +70°C case temperature.

Parameter	Symbol	Min	Typ	Max	Units	Ref.
Case Operating Temperature	T _{op}	-5		70	°C	
Storage Temperature	T _{sto}	-40		85	°C	

VII. Regulatory Compliance

Finisar XFP transceivers are Class 1 Laser Products. They are certified per the following standards:

Feature	Agency	Standard	Certificate Number
Laser Eye Safety	FDA/CDRH	CDRH 21 CFR 1040 and Laser Notice 50	9210176-77
Laser Eye Safety	TÜV	EN 60825-1: 1994+A11:1996+A2:2001 IEC 60825-1: 1993+A1:1997+A2:2001 IEC 60825-2: 2000, Edition 2	R72052602
Electrical Safety	TÜV	EN 60950	R72052602
Electrical Safety	UL/CSA	CLASS 3862.07 CLASS 3862.87	1439230

Copies of the referenced certificates are available at Finisar Corporation upon request.

VIII. Digital Diagnostics Functions

As defined by the XFP MSA¹, Finisar XFP transceivers provide digital diagnostic functions via a 2-wire serial interface, which allows real-time access to the following operating parameters:

- Transceiver temperature
- Laser bias current
- Transmitted optical power
- Received optical power
- Transceiver supply voltage
- TEC Temperature

It also provides a sophisticated system of alarm and warning flags, which may be used to alert end-users when particular operating parameters are outside of a factory-set normal range.

The operating and diagnostics information is monitored and reported by a Digital Diagnostics Transceiver Controller (DDTC) inside the transceiver, which is accessed through the 2-wire serial interface. When the serial protocol is activated, the serial clock signal (SCL pin) is generated by the host. The positive edge clocks data into the XFP transceiver into those segments of its memory map that are not write-protected. The negative edge clocks data from the XFP transceiver. The serial data signal (SDA pin) is bi-directional for serial data transfer. The host uses SDA in conjunction with SCL to mark the start and end of serial protocol activation. The memories are organized as a series of 8-bit data words that can be addressed individually or sequentially. The 2-wire serial interface provides sequential or random access to the 8 bit parameters, addressed from 000h to the maximum address of the memory.

For more detailed information, including memory map definitions, please see the XFP MSA documentation¹.

Receiver Threshold Adjustment

The FTLX3812S3xx provides access to receiver decision threshold adjustment via the 2-wire serial interface, in order to improve receiver OSNR performance based on specific link conditions. It is implemented as follows:

- Rx Threshold of XFP transceivers will be factory-set for optimized performance in non-FEC applications. This will be the default value during both cold start (power-up) and warm start (module reset).
- The transceiver supports adjustment of Rx Threshold value by the host through register 76d, table 01h. This is intended to be used in FEC applications.

- Register 76d, table 01h is a volatile memory. Therefore if the transceiver is power-cycled, the register starts up with a value of 00h which corresponds to the default Rx Threshold value.
- The threshold adjustment input value is 2's complement 7 bit value (-128 to +127), with 0 corresponding to default Rx threshold value. Full range of adjustment provides at least a $\pm 10\%$ change in Rx threshold from the default value.

IX. Mechanical Specifications

Finisar's XFP transceivers are compliant with the dimensions defined by the XFP Multi-Sourcing Agreement (MSA).

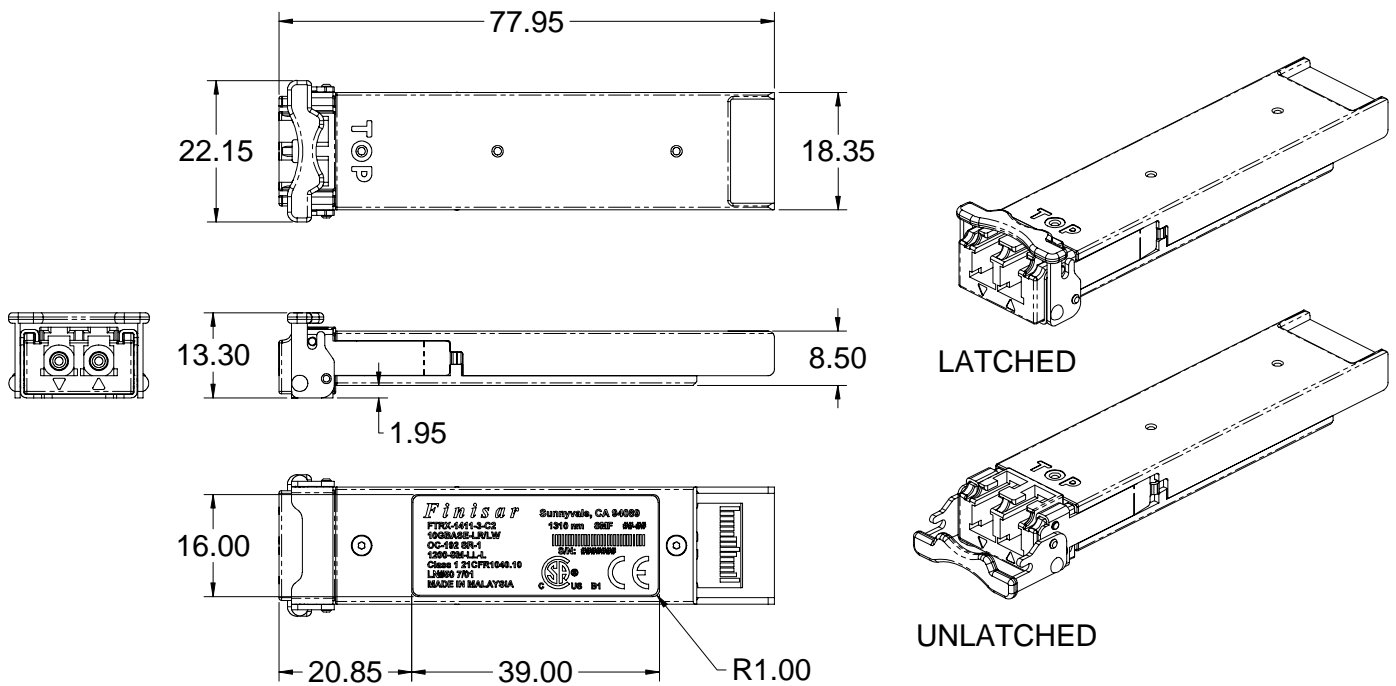

XFP Transceiver (dimensions are in mm)

X. PCB Layout and Bezel Recommendations

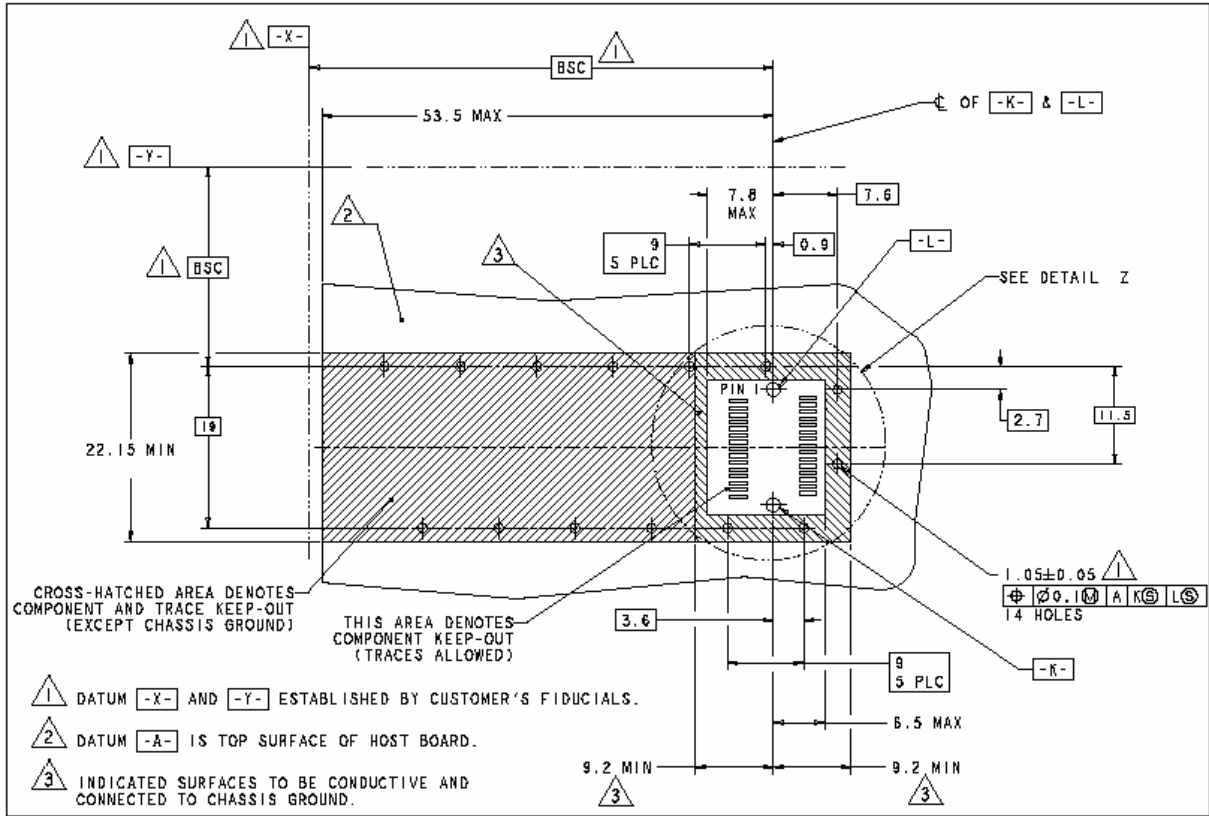

XFP Host Board Mechanical Layout (dimensions are in mm)

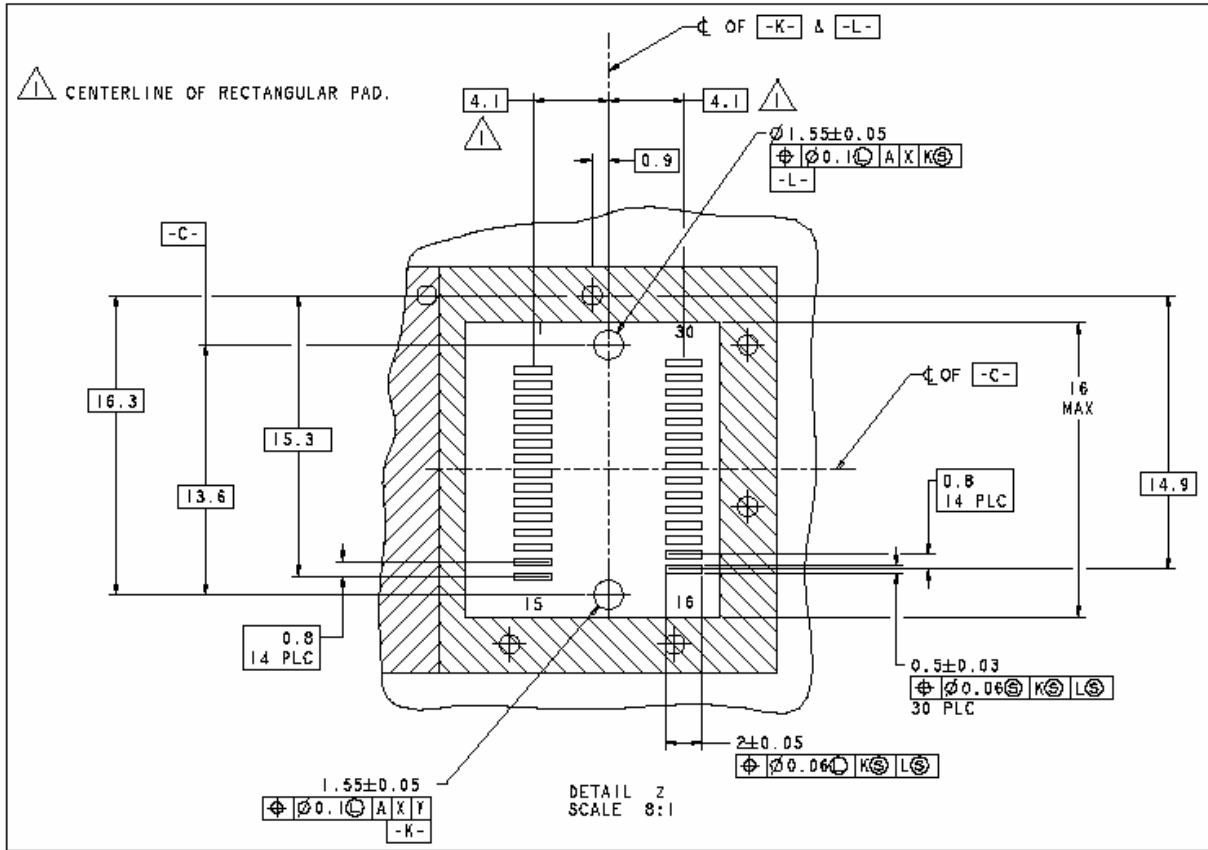

XFP Detail Host Board Mechanical Layout (dimensions are in mm)

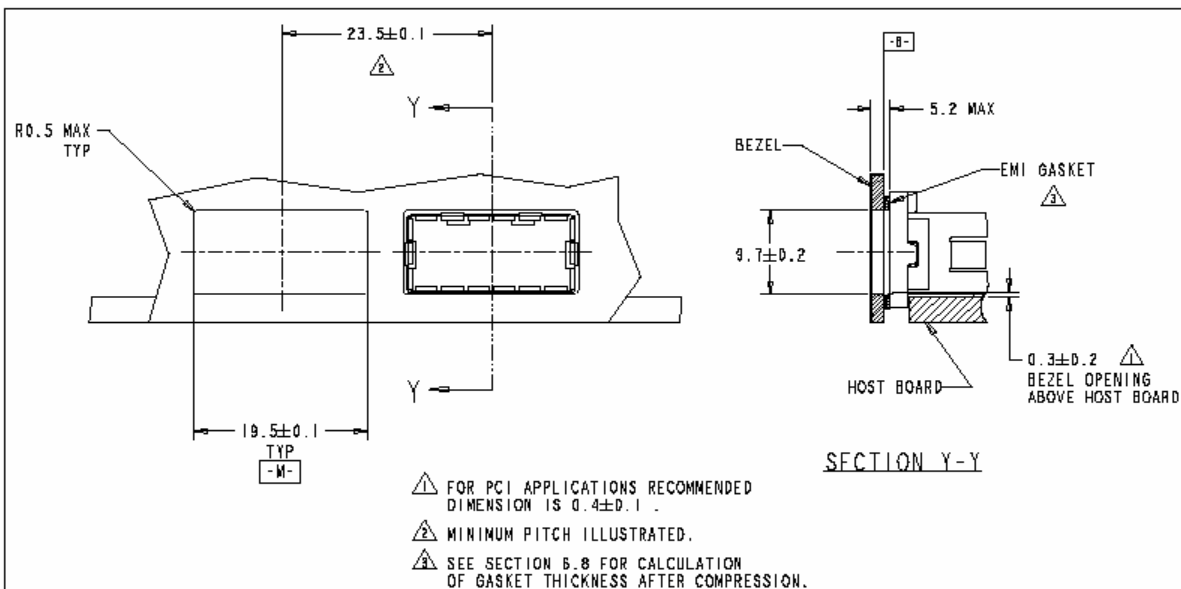

XFP Recommended Bezel Design (dimensions are in mm)

XI. References

1. 10 Gigabit Small Form Factor Pluggable Module (XFP) Multi-Source Agreement (MSA), Rev 4.5 – August 2005. Documentation is currently available at <http://www.xfpmsa.org/>
2. Application Note AN-2035: “Digital Diagnostic Monitoring Interface for XFP Optical Transceivers” – Finisar Corporation, December 2003
3. Directive 2002/95/EC of the European Council Parliament and of the Council, “on the restriction of the use of certain hazardous substances in electrical and electronic equipment”. January 27, 2003.
4. “Application Note AN-2038: Finisar Implementation Of RoHS Compliant Transceivers”, Finisar Corporation, January 21, 2005.

XII. Revision History

Revision	Date	Description
A	4/12/2006	<ul style="list-style-type: none"> • Document created.
A1	4/12/2006	<ul style="list-style-type: none"> • Updated Finisar Address
A2	5/22/2006	<ul style="list-style-type: none"> • Update BOL wavelength tolerance specification.
B	10/25/2006	<ul style="list-style-type: none"> • Added Safety Certificate numbers. • Document released.
B1	9/28/2007	<ul style="list-style-type: none"> • Updated note on channels.

XII. For More Information

Finisar Corporation
 1389 Moffett Park Drive
 Sunnyvale, CA 94089-1133
 Tel. 1-408-548-1000
 Fax 1-408-541-6138
sales@finisar.com
www.finisar.com