

STRUCTURE	Silicon monolithic integrated circuits
PRODUCTSERIES	3-phase brushless motor driver
TYPE	<b>BD67922EFV</b>
FUNCTION	<ul style="list-style-type: none"> <li>• 3-phase MOS direct PWM driver</li> <li>• Built-in PLL control circuit</li> <li>• Built-in over current protection circuit</li> </ul>

## ○Absolute maximum ratings (Ta=25°C)

Item	Symbol	Limit	Unit
Supply voltage	V <sub>CC</sub>	-0.2~+36.0	V
LD, FG applied voltage	V <sub>LD, FG</sub>	-0.2~+6.5	V
HB applied voltage	V <sub>HB</sub>	-0.2~+6.5	V
Hall signal input voltage	V <sub>HALL</sub>	-0.2~+6.5	V
Input voltage for CLK pin	V <sub>CLK</sub>	-0.2~+6.5	V
Input voltage for control pin (SS, SB)	V <sub>IN</sub>	-0.2~+6.5	V
Power dissipation	Pd	1.45 <sup>※1</sup>	W
		4.70 <sup>※2</sup>	W
Output current	I <sub>OUT</sub>	2300 <sup>※3</sup>	mA
Operating temperature range	T <sub>opr</sub>	-25~+85	°C
Storage temperature range	T <sub>stg</sub>	-55~+150	°C
Junction temperature	T <sub>jmax</sub>	+150	°C

※1 70mm × 70mm × 1.6mm glass epoxy board. Derating is done at 11.6mW/°C for operating above Ta=25°C.

※2 4-layer recommended board. Derating is done at 37.6mW/°C for operating above Ta=25°C.

※3 Do not, however exceed Pd, ASO, and T<sub>jmax</sub>=150°C.

## ○Recommend operating conditions (Ta= -25~+85°C)

Item	Symbol	Min.	Typ.	Max.	Unit
Supply voltage	V <sub>CC</sub>	19	24	28	V
5V constant voltage output current	I <sub>REG</sub>	-20	-	0	mA
HB pin current	I <sub>HB</sub>	0	-	20	mA
LD, FG pin supply voltage	V <sub>LD, FG</sub>	0	-	5.5	V
LD, FG pin current	I <sub>LD, FG</sub>	0	-	15	mA

This product isn't designed for protection against radioactive rays.

○Electrical characteristics (Unless otherwise specified, Ta=25°C, V<sub>CC</sub>=24V)

Item	Symbol	Limit			Unit	Conditions
		Min.	Typ.	Max.		
<b>Whole</b>						
Circuit current 1	I <sub>CC1</sub>	-	4.0	9.0	mA	SS=L output ON mode
Circuit current 2	I <sub>CC2</sub>	-	1.5	2.3	mA	SS=H output OFF mode
<b>VREG output</b>						
Output voltage	V <sub>REG</sub>	4.65	5.00	5.35	V	
<b>Output (U, V, W)</b>						
Output on resistance	R <sub>ON</sub>	-	1.35	1.76	Ω	I <sub>OUT</sub> =1.0A Sum of upper and lower
Lower side diode forward voltage	V <sub>D1</sub>	0.70	1.10	1.55	V	I <sub>OUT</sub> =-1.0A
Upper side diode forward voltage	V <sub>D2</sub>	0.70	1.10	1.55	V	I <sub>OUT</sub> =1.0A
Output leak current	I <sub>LEAK</sub>	-	-	10	μA	
<b>Hall comparator Input (HUP, HUN, HVP, HVN, HWP, HWN)</b>						
Common mode input voltage range	V <sub>ICM</sub>	1.5	-	3.5	V	
Hysteresis width	ΔV <sub>IN</sub>	15	24	42	mV	Sum of upper and lower
<b>LD, FG output</b>						
Low level output voltage	V <sub>OD</sub>	-	0.15	0.50	V	I <sub>LD, FG</sub> =10mA
<b>PD output</b>						
High level output voltage	V <sub>PDH</sub>	4.5	4.9	-	V	I <sub>PD</sub> =-100 μA
Low level output voltage	V <sub>PDL</sub>	-	0.2	0.3	V	I <sub>PD</sub> =100 μA
<b>Integral amplifier</b>						
EO High level output voltage	V <sub>EOH</sub>	3.5	4.1	-	V	I <sub>EO</sub> =-500 μA
EO Low level output voltage	V <sub>EOH</sub>	-	0.9	1.5	V	I <sub>EO</sub> =500 μA
EI input current	I <sub>EI</sub>	-2.0	-0.1	-	μA	V <sub>EI</sub> =0V
<b>Current limit circuit</b>						
Drive gain during starting mode	G <sub>H</sub>	1.2	1.5	1.8	times	
Drive gain during steady mode	G <sub>L</sub>	0.4	0.5	0.6	times	
Limiter voltage	V <sub>CL</sub>	0.45	0.50	0.55	V	
<b>CLK input</b>						
External input frequency	F <sub>CLK</sub>	-	-	10	kHz	
High level input voltage	V <sub>CLKH</sub>	3.0	-	-	V	
Low level input voltage	V <sub>CLKL</sub>	-	-	1.5	V	
Low level input current	I <sub>CLKL</sub>	-75	-50	-25	μA	V <sub>CLK</sub> =0V
<b>Control input (SS, SB)</b>						
High level input voltage	V <sub>INH</sub>	3.0	-	-	V	
Low level input voltage	V <sub>INL</sub>	-	-	1.5	V	
Low level input current	I <sub>INL</sub>	-75	-50	-25	μA	V <sub>IN</sub> =0V
<b>OSC</b>						
OSC oscillating frequency	F <sub>OSC</sub>	130	200	270	kHz	C <sub>OSC</sub> =220pF
OSC High voltage	V <sub>OSCH</sub>	1.6	2.0	2.4	V	
OSC Low voltage	V <sub>OSCL</sub>	1.2	1.5	1.8	V	
<b>PROCLK</b>						
CLK cycle for protection circuit	T <sub>PCLK</sub>	13	20	27	msec	C <sub>PCLK</sub> =0.1 μF
<b>Hall bias</b>						
Hall bias voltage	V <sub>HB</sub>	0.70	0.85	1.00	V	I <sub>HB</sub> =10mA

○Package outline

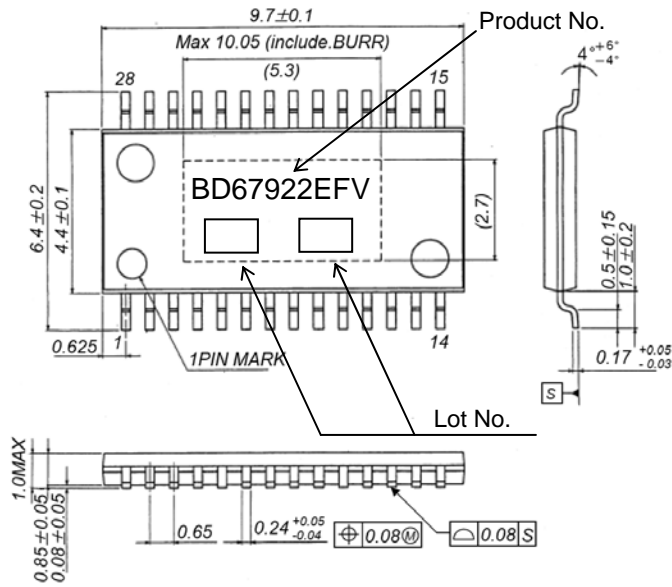

HTSSOP-B28 (Unit: mm)

○Pin No. / Pin name

Pin No.	Pin name	Pin No.	Pin name
1	GND	15	HUP
2	VCC	16	VREG
3	FG	17	PD
4	CS	18	TEST
5	RNF	19	EI
6	W	20	EO
7	V	21	PROCLK
8	U	22	CLK
9	HB	23	SS
10	HWN	24	LD
11	HWP	25	OSC
12	HVN	26	BRMODE
13	HVP	27	CNF
14	HUN	28	SB

○Block diagram

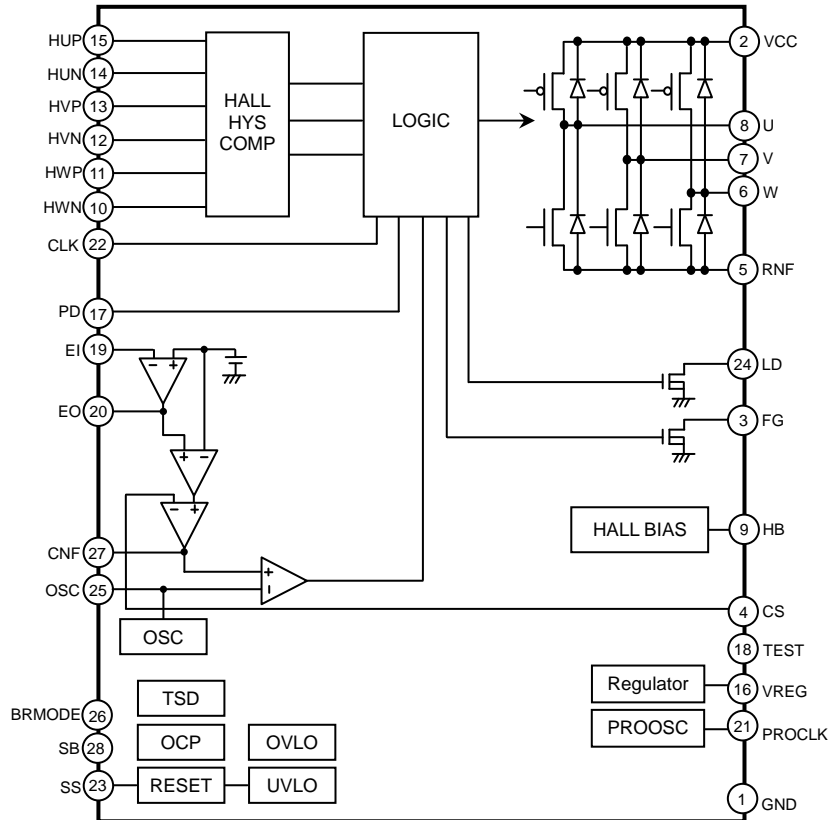

## ○Operation Notes

- (1) Absolute maximum ratings  
An excess in the absolute maximum ratings, such as supply voltage, temperature range of operating conditions, etc., can break down the devices, thus making impossible to identify breaking mode, such as a short circuit or an open circuit. If any over rated values will expect to exceed the absolute maximum ratings, consider adding circuit protection devices, such as fuses.
- (2) Power supply lines  
As return of current regenerated by back EMF of motor happens, take steps such as putting capacitor between power supply and GND as an electric pathway for the regenerated current. Be sure that there is no problem with each property such as emptied capacity at lower temperature regarding electrolytic capacitor to decide capacity value. If the connected power supply does not have sufficient current absorption capacity, regenerative current will cause the voltage on the power supply line to rise, which combined with the product and its peripheral circuitry may exceed the absolute maximum ratings. It is recommended to implement a physical safety measure such as the insertion of a voltage clamp diode between the power supply and GND pins.
- (3) GND potential  
The potential of GND pin must be minimum potential in all operating conditions.
- (4) Metal on the backside (Define the side where product markings are printed as front)  
The metal on the backside is shorted with the backside of IC chip therefore it should be connected to GND. Be aware that there is a possibility of malfunction or destruction if it is shorted with any potential other than GND.
- (5) Thermal design  
Use a thermal design that allows for a sufficient margin in light of the power dissipation (Pd) in actual operating conditions. This IC exposes its frame of the backside of package. Note that this part is assumed to use after providing heat dissipation treatment to improve heat dissipation efficiency. Try to occupy as wide as possible with heat dissipation pattern not only on the board surface but also the backside.
- (6) Actions in strong electromagnetic field  
The IC is not designed for using in the presence of strong electromagnetic field. Be sure to confirm that no malfunction is found when using the IC in a strong electromagnetic field.
- (7) ASO  
When using the IC, set the output transistor so that it does not exceed absolute maximum ratings or ASO.
- (8) Thermal shutdown circuit  
The IC has a built-in thermal shutdown circuit (TSD circuit). If the chip temperature becomes  $T_{jmax}=150^{\circ}\text{C}$ , and higher, coil output to the motor will be open. The TSD circuit is designed only to shut the IC off to prevent runaway thermal operation. It is not designed to protect or indemnify peripheral equipment. Do not use the TSD function to protect peripheral equipment.
- (9) Ground Wiring Pattern  
When using both large current and small signal GND patterns, it is recommended to isolate the two ground patterns, placing a single ground point at the ground potential of application so that the pattern wiring resistance and voltage variations caused by large currents do not cause variations in the small signal ground voltage. Be careful not to change the GND wiring pattern of any external components, either.
- (10) Mounting errors and Inter-pin short  
When attaching to a printed circuit board, pay attention to the direction of the IC and displacement. Improper attachment may lead to destruction of the IC. There is also possibility of destruction from short-circuits which can be caused by foreign matter entering between pins.
- (11) TEST pin  
Be sure to connect TEST pin to GND.

## Notes

No copying or reproduction of this document, in part or in whole, is permitted without the consent of ROHM Co.,Ltd.

The content specified herein is subject to change for improvement without notice.

The content specified herein is for the purpose of introducing ROHM's products (hereinafter "Products"). If you wish to use any such Product, please be sure to refer to the specifications, which can be obtained from ROHM upon request.

Examples of application circuits, circuit constants and any other information contained herein illustrate the standard usage and operations of the Products. The peripheral conditions must be taken into account when designing circuits for mass production.

Great care was taken in ensuring the accuracy of the information specified in this document. However, should you incur any damage arising from any inaccuracy or misprint of such information, ROHM shall bear no responsibility for such damage.

The technical information specified herein is intended only to show the typical functions of and examples of application circuits for the Products. ROHM does not grant you, explicitly or implicitly, any license to use or exercise intellectual property or other rights held by ROHM and other parties. ROHM shall bear no responsibility whatsoever for any dispute arising from the use of such technical information.

The Products specified in this document are intended to be used with general-use electronic equipment or devices (such as audio visual equipment, office-automation equipment, communication devices, electronic appliances and amusement devices).

The Products specified in this document are not designed to be radiation tolerant.

While ROHM always makes efforts to enhance the quality and reliability of its Products, a Product may fail or malfunction for a variety of reasons.

Please be sure to implement in your equipment using the Products safety measures to guard against the possibility of physical injury, fire or any other damage caused in the event of the failure of any Product, such as derating, redundancy, fire control and fail-safe designs. ROHM shall bear no responsibility whatsoever for your use of any Product outside of the prescribed scope or not in accordance with the instruction manual.

The Products are not designed or manufactured to be used with any equipment, device or system which requires an extremely high level of reliability the failure or malfunction of which may result in a direct threat to human life or create a risk of human injury (such as a medical instrument, transportation equipment, aerospace machinery, nuclear-reactor controller, fuel-controller or other safety device). ROHM shall bear no responsibility in any way for use of any of the Products for the above special purposes. If a Product is intended to be used for any such special purpose, please contact a ROHM sales representative before purchasing.

If you intend to export or ship overseas any Product or technology specified herein that may be controlled under the Foreign Exchange and the Foreign Trade Law, you will be required to obtain a license or permit under the Law.



Thank you for your accessing to ROHM product informations.  
More detail product informations and catalogs are available, please contact us.

## ROHM Customer Support System

<http://www.rohm.com/contact/>