

OC-3 SFP Transceiver (1310 nm and 1550 nm) CT2 Series



Key Features

- SFP MSA compatible
- Fully OC-3 SONET compliant at all reaches: IR-1, LR-1, and LR-2
- Microprocessor-based design fully implements the Digital Diagnostic Monitoring Interface
- Automatic output power and extinction ratio control over temperature and lifetime to compensate for laser efficiency degradation
- Expandable options, such as a custom software user interface

Applications

- Metro access
- Metro core
- Wide area networks

Compliance

- GR-253-CORE
- ITU-T G.957
- SFF-8472

The JDSU CT2 Series OC-3 (155 Mb/s) transceiver module integrates optics and electronics in a Small Form Factor Pluggable (SFP) package. It is Multisource Agreement (MSA) compatible and designed for operation at 1310 nm and 1550 nm.

The CT2 Series SFP transceiver provides a fully OC-3 SONET compliant interface between the SONET/SDH photonic layer and the electrical layer. Its microprocessor-based modular design implements all features specified in the SFP MSA compatible 2-wire Serial Digital Diagnostic Monitoring Interface for Optical Transceivers.

The major components in this module include a Fabry-Perot or uncooled distributed feedback (DFB) based optical transmitter, a PIN based optical receiver with integrated transimpedance amplifier (TIA), a microprocessor, a limiting post amplifier, and a laser driver. The modular transceiver design offers a "hot pluggable" interface, allowing the same basic architecture to be used for IR-1, LR-1, and LR-2 versions.

2

Dimensions Diagram

(Specifications in mm unless otherwise noted; see dimensions table on next page.)

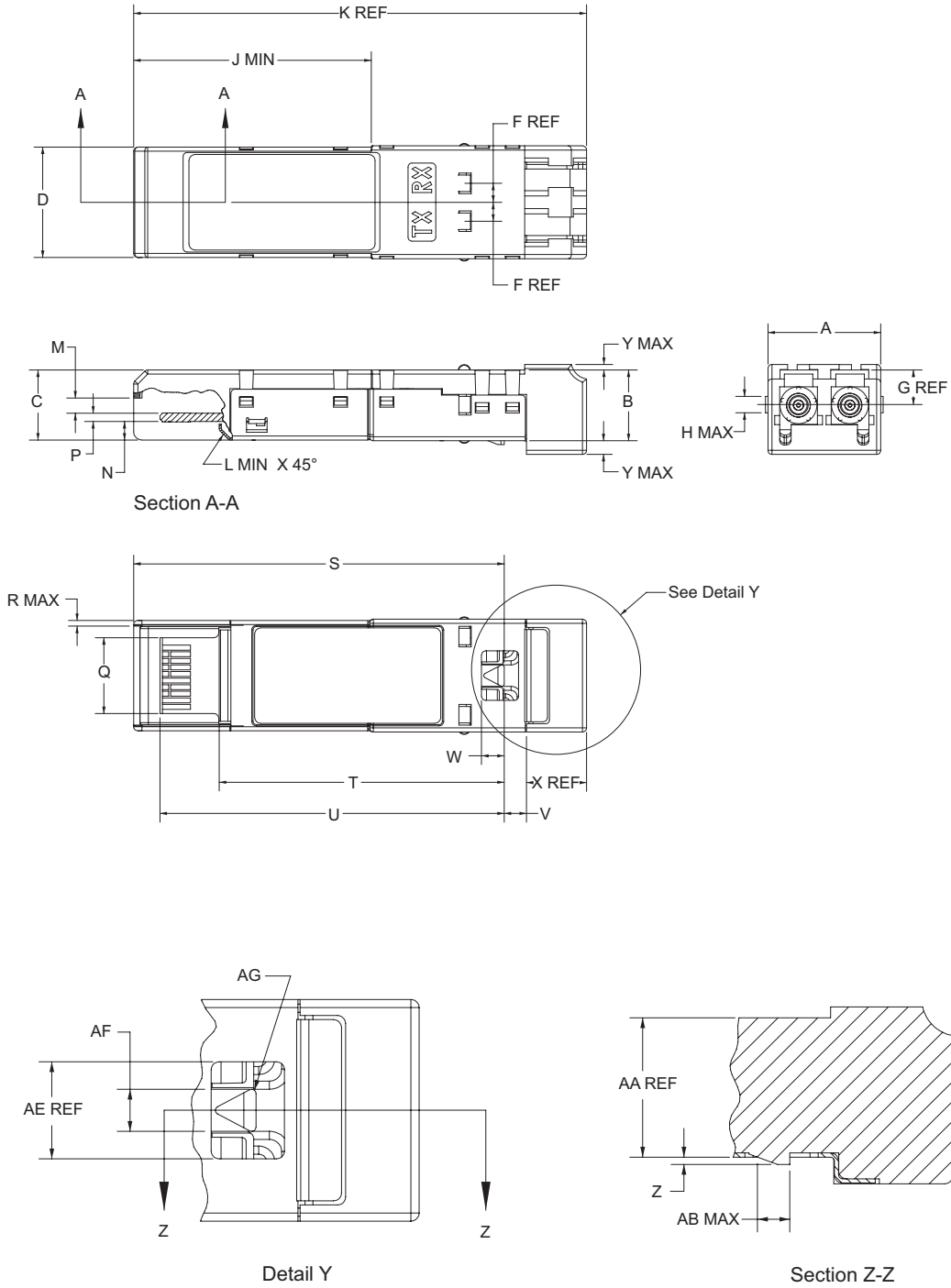

3

Dimension Table for the CT2

Designator	Dimension	Tolerance	Comments
A	13.7 mm	±0.1 mm	Transceiver width, nose piece or front that extends inside cage
B	8.6 mm	±0.1 mm	Transceiver height, front, that extends inside cage
C	8.5 mm	±0.1 mm	Transceiver height, rear
D	13.4 mm	±0.1 mm	Transceiver width, rear
E	1.0 mm	Maximum	Extension of front sides outside of cage
F	2.3 mm	Reference	Location of cage grounding springs from centerline, top
G	4.2 mm	Reference	Location of side cage grounding springs from top
H	2.0 mm	Maximum	Width of cage grounding springs
J	28.5 mm	Minimum	Location of transition between nose piece and rear of transceiver
K	55.0 mm	Reference	Transceiver overall length
L	1.1 mm x 45°	Minimum	Chamfer on bottom of housing
M	2.0 mm	±0.25 mm	Height of rear shoulder from transceiver printed circuit board
N	2.25 mm	±0.1 mm	Location of printed circuit board to bottom of transceiver
P	1.0 mm	±0.1 mm	Thickness of printed circuit board
Q	9.2 mm	±0.1 mm	Width of printed circuit board
R	0.7 mm	Maximum	Width of skirt in rear of transceiver
S	45.0 mm	±0.2 mm	Length from latch shoulder to rear of transceiver
T	34.6 mm	±0.3 mm	Length from latch shoulder to bottom opening of transceiver
U	41.8 mm	±0.15 mm	Length from latch shoulder to end of printed circuit board
V	2.7 mm	±0.05 mm	Length from latch shoulder to shoulder of transceiver outside of cage (location of positive stop)
W	2.7 mm	±0.1 mm	Clearance for actuator tines
X	7.3 mm	Reference	Transceiver length extending outside of cage
Y	2.0 mm	Maximum	Maximum length of top and bottom transceiver extending outside of cage
Z	0.45 mm	±0.05 mm	Height of latch boss
AA	8.6 mm	Reference	Transceiver height, front, that extends inside the cage
AB	2.6 mm	Maximum	Length of latch boss
AE	6.0 mm	Reference	Width of cavity that contains the actuator

Bail Latch Color Code Definition

Bail Latch Color	Wavelength	Typical Reach
Yellow	1310 nm	IR (15 km)
Red	1310 nm	LR (40 km)
White	1550 nm	LR (80 km)

4

CT2 Electrical Pad Layout

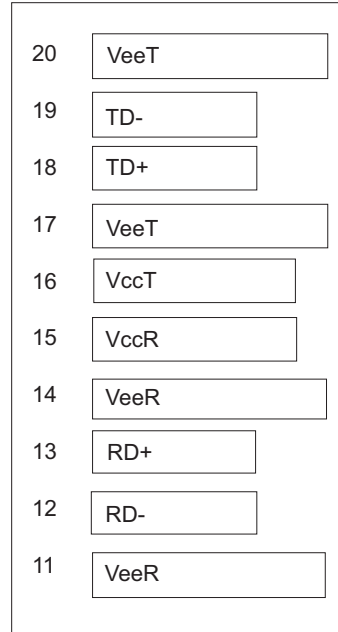

Top of Board

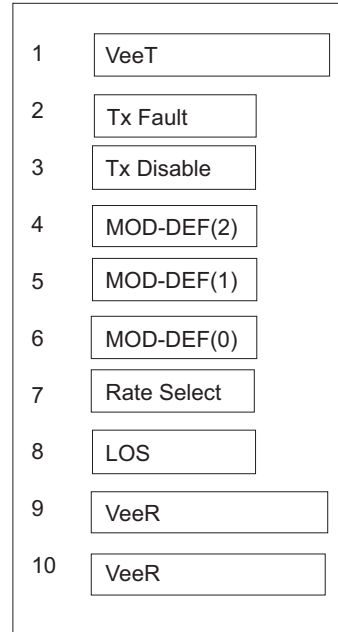

Bottom of Board (As Viewed through Top of Board)

Transceiver Pin Descriptions

Pin	Description
TD	Un-clocked, multirate, differential serial bit stream (OC-3) used to drive the optical transmitter.
TD _b	Internally AC coupled and terminated via internal 100 Ω differential impedance.
RD	Differential received electrical signal capable of detecting OC-3 bit patterns.
RD _b	The differential pair is internally biased and AC coupled. This signal requires 100 Ω external differential termination.
Rate_select	Internally monitored and available for future use. Can be customized for specific applications.
TxDIS	Transmitter Disable Input. A logic HIGH on this input pin disables the transmitter's laser so that there is no optical output. If left open the transmitter will be disabled.
LOS	Loss of Signal (Open Collector). A logic HIGH on this output indicates an incoming signal level that is less than -36 dBm but no greater than -44 dBm. LOS shall deassert (logic LOW) when a 3 dB (maximum), 0.5 dB (minimum) hysteresis is obtained.
Tx_fault	Transmitter fault (Open collector). A logic HIGH indicates that the transmitter is in a fault condition.
MOD_DEF(0)	MOD_DEF(0) is internally grounded to indicate the presence of the module. Must be pulled-up on host board with a 10 KΩ resistor.
MOD_DEF(1)	MOD_DEF(1) is the clock of the 2 wire interface for module monitoring.
MOD_DEF(2)	MOD_DEF(2) is the data line of the 2 wire interface for module monitoring.
VccR,VccT	Receiver, Transmitter power supply, respectively
VeeR, VeeT	Receiver, Transmitter ground, respectively. The chassis ground and circuit ground isolation is configurable.

5

Absolute Maximum Ratings

Parameter	Minimum	Maximum
Extended operating case temperature range	-40 °C	85 °C
Storage case temperature range	-40 °C	85 °C
Supply voltage	-0.5 V	4.0 V
Voltage on any input/output pin	0 V	V _{cc}
High-speed output source current	-	50 mA
Lead soldering temperature/time	-	250 °C/10 seconds
Operating relative humidity (non-condensing)	5%	85%
Receiver optical input power (PIN)	-	3 dBm

Transceiver Electrical Input/Output Characteristics(V_{cc} = 3.3 V±5%)

Parameter	Minimum	Maximum
Input data signal levels input voltage swing, DVIN (internally AC coupled)	200 mV	2000 mV
Transmitter disable input (disabled/enabled)	2.0 V/0 V	V _{cc} /0.8 V
Rate select input (high data rate/low data rate)	2.8 V/0 V	V _{cc} /0.6 V
Transmitter fault output (asserted/deasserted)	2.4 V/0 V	V _{cc} /0.5 V
Output data signal levels ¹ output voltage swing, DVOOUT (internally AC coupled)	400 mV	2000 mV
Loss-of-signal output (output high, VOH/output low, VOL)	2.4 V/0 V	V _{cc} /0.5 V

1. Terminated into 100 Ω differential. These levels are guaranteed down to 2 dB lower than the typical receiver sensitivity for each data rate and reach.

6

Timing of Status and Control Input/Output

Parameter	Symbol	Condition	Specification
TX_DISABLE assert time	t_off	Time from rising edge of TX_DISABLE to when the output optical power falls below 10% of nominal	Maximum 10 μ s
TX_DISABLE deassert time	t_on	Time from falling edge of TX_DISABLE to when the output optical power rises above 90% of nominal	Maximum 10 μ s
Time to initialize	t_init	Upon power up or negation of TX_FAULT due to TX_DISABLE	Maximum 300 ms
TX_FAULT assert time	t_fault	Time from a fault condition to TX_FAULT assertion	Maximum 100 μ s
TX_DISABLE for reset	t_reset	Time TX_DISABLE must be held HIGH to reset TX_FAULT	Minimum 10 μ s
LOS assert time	t_loss_on	Time from loss of signal to assertion of LOS	Maximum 100 μ s
LOS deassert time	t_loss_off	Time from non-loss condition to LOS deassertion	Maximum 100 μ s
2-wire serial clock rate	f_serial_clock	-	Maximum 100 kHz

Power Supply Voltage

Parameter		IR-1	LR-1	LR-2
Supply voltage	Minimum	3.1 V	3.1 V	3.1 V
	Typical	3.3 V	3.3 V	3.3 V
	Maximum	3.5 V	3.5 V	3.5 V
Power supply current drain ¹	Typical	222 mA	245 mA	245 mA
	Maximum	300 mA	300 mA	300 mA

1. Applies to hardware revision 2. Does not include output termination resistor current.

7

Specifications

Parameter		IR-1	LR-1	LR-2
Average output power ¹	Minimum	-15 dBm	-5 dBm	-5 dBm
	Typical	-	-2.5 dBm	-2.5 dBm
	Maximum	-8 dBm	0 dBm	0 dBm
BOL power output ¹	Minimum	-	-4 dBm	-4 dBm
	Typical	-	-2.5 dBm	-2.5 dBm
	Maximum	-	-1 dBm	-1 dBm
TX operating wavelength	Minimum	1261 nm	1263 nm	1480 nm
	Typical	-	1310 nm	1550 nm
	Maximum	1360 nm	1360 nm	1580 nm
Spectral width ² (rms)	Typical	-	-	0.3 nm
	Maximum	4 nm	3 nm	1 nm
Side mode suppression ratio ³ (DFB laser)	Minimum	-	-	30 dB
Extinction ratio ⁴ (BOL)	Minimum	-	11.0 dB	11.0 dB
	Typical	-	12.0 dB	12.0 dB
	Maximum	-	14.0 dB	14.0 dB
Extinction ratio ⁴ (EOL)	Minimum	8.2 dB	10.0 dB	10.0 dB
Optical rise and fall times (20 to 80%)	Maximum	2200 ps	300 ps	300 ps
Eye mask of optical output	Compliant with Bellcore TR-NWT-000253			
Eye mask margin ⁵ (filtered)	Minimum	-	25%	25%
Operating receiver wavelength	Minimum	1265 nm	1260 nm	1260 nm
	Maximum	1625 nm	1620 nm	1620 nm
Jitter generation (peak-to-peak) ⁶	Maximum	-	30 mUI _{P-P}	30 mUI _{P-P}
Jitter generation (rms) ⁶	Maximum	-	3 mUI _{rms}	3 mUI _{rms}
Power output with transmitter disabled	Typical	-	-50 dBm	-
	Maximum	-	-40 dBm	-40 dBm
Receiver sensitivity (BOL, BER=1 x 10 ⁻¹⁰ , ER=12 dB)	Minimum	-	-36 dBm	-36 dBm
	Typical	-	-37 dBm	-37 dBm
Receiver sensitivity (EOL, BER=1 x 10 ⁻¹⁰ , ER=10 dB)	Minimum	-28 dBm	-34 dBm	-34 dBm
Maximum received optical power	Minimum	-8 dBm	-10 dBm	-10 dBm
Link status response time	Minimum	3 μs	3 μs	3 μs
	Typical	50 μs	50 μs	50 μs
	Maximum	100 μs	100 μs	100 μs
Optical path penalty	Maximum	1 dB	1 dB	1 dB
Dispersion	Maximum	-	246 ps/nm	-
Receiver reflectance	Maximum	-	-	-25 dB
Minimum optical return loss	Minimum	-	-	-24 dB
BER floor	Maximum	10 ⁻¹⁵	10 ⁻¹⁵	10 ⁻¹⁵
Reflect into Tx for <1 dB degradation at the receiver	Maximum	-	-	-24 dB
Standard case temperature		-5 to 75 °C	-5 to 75 °C	-5 to 75 °C
Extended case temperature		-40 to 85 °C	-40 to 85 °C	-40 to 85 °C
Bit rate		155 Mb/s	155 Mb/s	155 Mb/s

1. Measured as fiber coupled power into a standard single mode fiber, typical connector repeatability is ±1 dB. LC duplex cables manufactured by Stratos are not recommended due to a potentially larger window of repeatability.
2. Full spectral width measured 20 dB down from the central wavelength peak under fully modulated conditions.
3. Ratio of the average output power in the dominant longitudinal mode to the power in the most significant side mode in fully modulated conditions.
4. Ratio of logic 1 output power to logic 0 output power under fully modulated conditions with a PRBS 23 data pattern.
5. GR-253-CORE, ITU-T, Recommendation G.957. Tested at STM1, STM4, STM16.
6. Formatted OC-3 pattern with scrambled PRBS payload using an Agilent OmniBer as the optical source driving the CT2 optical receiver. The differential data outputs of this optical receiver are used as the electrical inputs for the CT2 transmitter which optically drives the OmniBer receiver input to complete the jitter test circuit. This is a 60 second test as recommended in GR-253.

Ordering Information

For more information on this or other products and their availability, please contact your local JDSU account manager or JDSU directly at 1-800-498-JDSU (5378) in North America and +800-5378-JDSU worldwide or via e-mail at customer.service@jdsu.com.

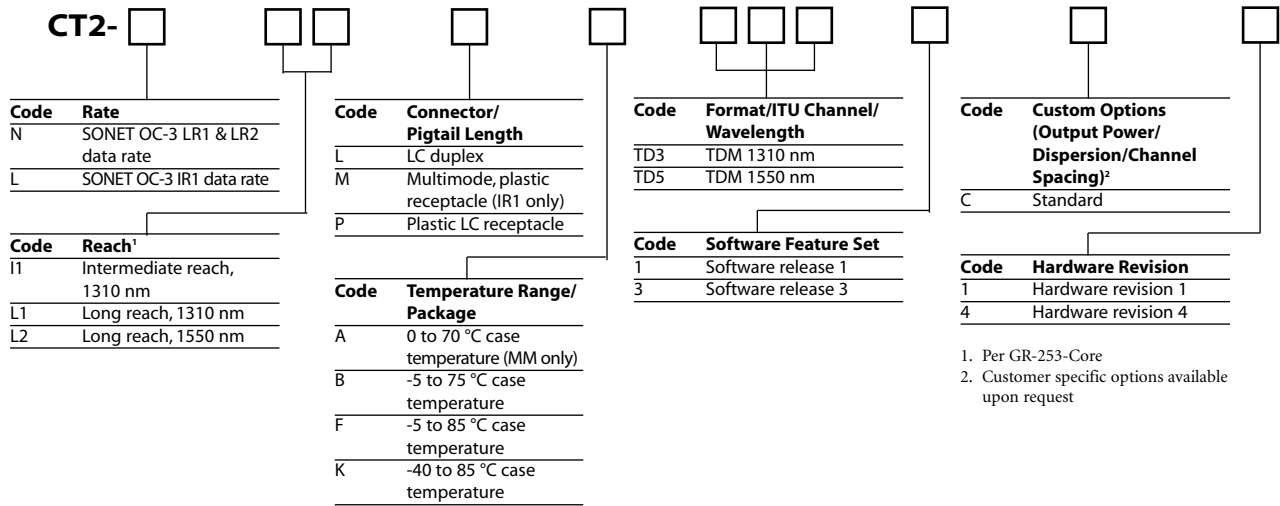
Sample: CT2-NL1LBTD31C1

1. Per GR-253-Core
2. Customer specific options available upon request

Telcordia is a registered trademark of Telcordia Technologies Incorporated.

All statements, technical information and recommendations related to the products herein are based upon information believed to be reliable or accurate. However, the accuracy or completeness thereof is not guaranteed, and no responsibility is assumed for any inaccuracies. The user assumes all risks and liability whatsoever in connection with the use of a product or its application. JDSU reserves the right to change at any time without notice the design, specifications, function, fit or form of its products described herein, including withdrawal at any time of a product offered for sale herein. JDSU makes no representations that the products herein are free from any intellectual property claims of others. Please contact JDSU for more information. JDSU and the JDSU logo are trademarks of JDS Uniphase Corporation. Other trademarks are the property of their respective holders. ©2006 JDS Uniphase Corporation. All rights reserved. 10143021 Rev.005 08/06 CT2OC3.DS.CMS.AE