

M24758/17-16-A

Basic Part No.

Conduit Size Code
(See Table I)

Material Designator:

A = Aluminum

B = Brass

C = CRES 316

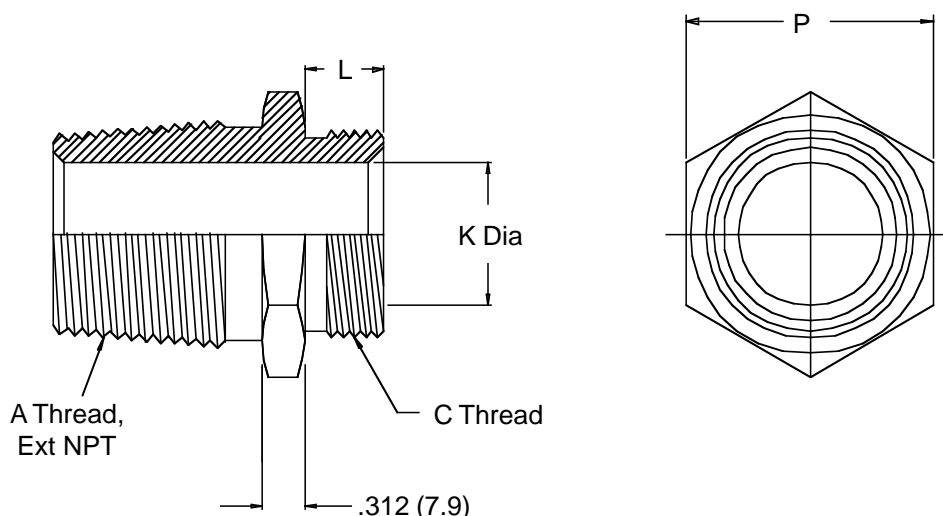

TABLE I

Conduit Size Code	A Thread	P Dia (Minimum)	C Thread (Class 2A)	L		K Dia Min.
				±.02	(.5)	
02	0.250 - 18.00 NPT	.690 (17.5)	0.438 - 28 UNEF	.210	(5.3)	.250 (6.4)
03	0.375 - 18.00 NPT	.810 (20.6)	0.563 - 24 UNEF	.250	(6.4)	.370 (9.4)
04	0.500 - 14.00 NPT	1.000 (25.4)	0.688 - 24 UNEF	.250	(6.4)	.500 (12.7)
05	0.750 - 14.00 NPT	1.180 (30.0)	0.813 - 20 UNEF	.310	(7.9)	.620 (15.7)
06	0.750 - 14.00 NPT	1.180 (30.0)	0.938 - 20 UNEF	.310	(7.9)	.750 (19.1)
08	1.000 - 11.50 NPT	1.500 (38.1)	1.250 - 18 UNEF	.370	(9.4)	1.000 (25.4)
10	1.250 - 11.50 NPT	1.810 (46.0)	1.563 - 18 UNEF	.370	(9.4)	1.250 (31.8)
12	1.500 - 11.50 NPT	2.120 (53.8)	1.875 - 16 UN	.430	(10.9)	1.500 (38.1)
16	2.000 - 11.50 NPT	2.620 (66.5)	2.375 - 16 UN	.430	(10.9)	2.000 (50.8)
20	2.500 - 8.00 NPT	3.000 (76.2)	2.875 - 16 UN	.430	(10.9)	2.500 (63.5)
24	3.000 - 8.00 NPT	3.620 (91.9)	3.375 - 16 UN	.430	(10.9)	3.000 (76.2)

1. The M24758/17 adapter couples any fittings having a female tapered pipe thread to M24758/2, M24758/3, or M24758/4 fittings.
2. Metric dimensions (mm) are indicated in parentheses.
3. For complete dimensions see applicable Military Specification.

M24758/18 Adapter for Straight Pipe Thread



Conduit Systems

M24758/18-16-A

Basic Part No.

Conduit Size Code
(See Table I)

Material Designator:

A = Aluminum

B = Brass

C = CRES 316

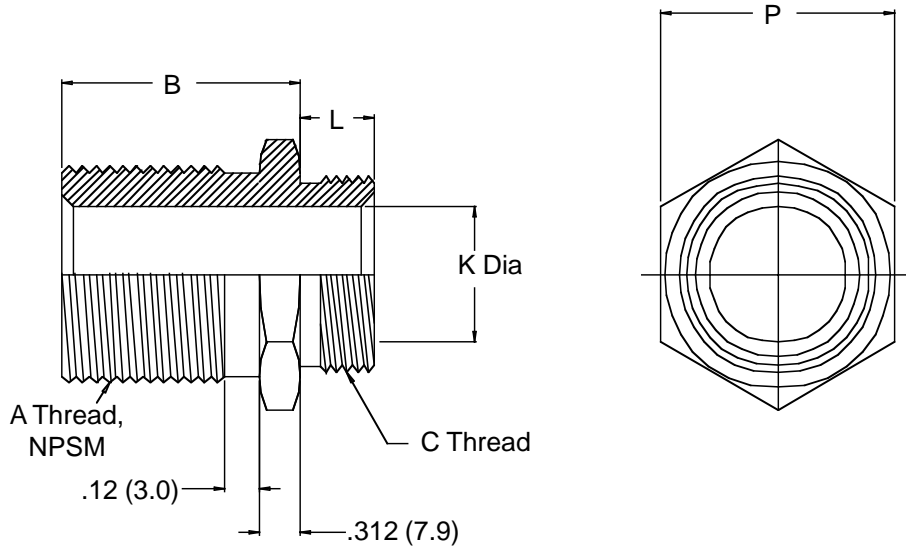

TABLE I

Conduit Size Code	A Pipe Thread	B Dim. ±.02 (.5)	P Dia (Minimum)	C Thread (Class 2A)	L ±.02 (.5)	K Dia Min.
02	0.250 - 18.00 NPSM	.750 (19.1)	.690 (17.5)	0.438 - 28 UNEF	.210 (5.3)	.250 (6.4)
03	0.375 - 18.00 NPSM	.750 (19.1)	.810 (20.6)	0.563 - 24 UNEF	.250 (6.4)	.370 (9.4)
04	0.500 - 14.00 NPSM	.870 (22.1)	1.000 (25.4)	0.688 - 24 UNEF	.250 (6.4)	.500 (12.7)
05	0.750 - 14.00 NPSM	.870 (22.1)	1.180 (30.0)	0.813 - 20 UNEF	.310 (7.9)	.620 (15.7)
06	0.750 - 14.00 NPSM	.870 (22.1)	1.180 (30.0)	0.938 - 20 UNEF	.310 (7.9)	.750 (19.1)
08	1.000 - 11.50 NPSM	.870 (22.1)	1.500 (38.1)	1.250 - 18 UNEF	.370 (9.4)	1.000 (25.4)
10	1.250 - 11.50 NPSM	.870 (22.1)	1.810 (46.0)	1.563 - 18 UNEF	.370 (9.4)	1.250 (31.8)
12	1.500 - 11.50 NPSM	1.000 (25.4)	2.120 (53.8)	1.875 - 16 UN	.430 (10.9)	1.500 (38.1)
16	2.000 - 11.50 NPSM	1.190 (30.2)	2.620 (66.5)	2.375 - 16 UN	.430 (10.9)	2.000 (50.8)
20	2.500 - 8.00 NPSM	1.620 (41.1)	3.000 (76.2)	2.875 - 16 UN	.430 (10.9)	2.500 (63.5)
24	3.000 - 8.00 NPSM	1.690 (42.9)	3.620 (91.9)	3.375 - 16 UN	.430 (10.9)	3.000 (76.2)

1. The M24758/18 adapter couples any fittings having a female straight pipe thread to M24758/2, M24758/3, or M24758/4 fittings.
2. Metric dimensions (mm) are indicated in parentheses.
3. For complete dimensions see applicable Military Specification.