



LinearDimensions
SEMICONDUCTOR

LND324 Quadruple Operational Amplifiers

GENERAL DESCRIPTION

The LND324 consists of four independent, High Gain, Internally Frequency compensated operational amplifiers that are designed specifically to operate from a single power supply over a wide range of voltages. Operation from split power supplies is also possible as long as the different between them is 3 volts to 32 volts.

Applications include transducer amplifiers, DC Amplification Blocks and all the conventional operational-amplifier circuits, that now can be more easily implemented in single-supply-voltage systems.

INTERNAL BLOCK DIAGRAM

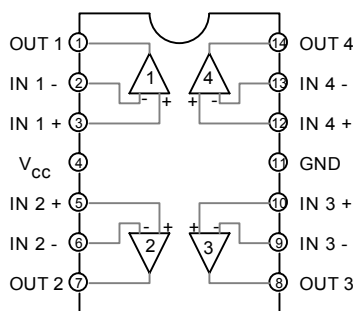

FEATURES

- Internally frequency compensated for unity Gain
- Large DC voltage gain: 100dB
- Wide Power Supply Range : 3V to 30V
- Input Common-Mode Voltage Range Includes Ground
- Large Output Voltage Swing 0V to $V_{CC}-1.5V$

ADVANTAGES

- Eliminates need for dual supplies
- Four internally compensated op amps in a single package
- Allows directly sensing near GND and V_{OUT} also goes to GND
- Compatible with all forms of logic
- Power drain suitable for battery operation



ELECTRICAL CHARACTERISTICS

ELECTRICAL CHARACTERISTICS at specified free-air temperature, $V_{CC}=5V$ (unless otherwise noted)

PARAMETER	TEST CONDITIONS*	LM324			UNIT	
		MIN	TYP	MAX		
V_{IO} Input offset voltage	$V_{CC}=5V$ to Max, V_{ICR} min, $V_O=1.4V$	25°C		3	7	mV
		Full Range			9	
αV_{IO} average temperature coefficient of input offset voltage		Full Range		7		$\mu V/^\circ C$
I_{IO} Input offset current	$V_O=1.4$	25°C		2	50	nA
		Full Range			150	
αI_{IO} Average temperature coefficient of input offset current		Full Range		10		$pA/^\circ C$
I_{IB} Input bias current	$V_O=1.4$	25°C		-20	-250	nA
		Full Range			-500	
V_{ICR} Common-mode input voltage range	$V_{CC}=5V$ to MAX	25°C	0		$V_{CC}-1.5$	V
		Full Range	0		$V_{CC}-2$	
V_{OH} High level output voltage	$R_L \geq 2k\Omega$	25°C			$V_{CC}-1.5$	V
	$V_{CC}=MAX$, $R_L=2k\Omega$	Full Range	26			
	$V_{CC}=MAX$, $R_L \geq 10k\Omega$	Full Range	27	28		
V_{OL} Low- level output voltage	$R_L \geq 10k\Omega$	Full Range		5	20	mV
A_{VD} Large signal differential voltage Amplification	$V_{CC}=15V$, $V_O=1v$ to 11V $R_L \geq 2k\Omega$	25°C	25	100		V/ mV
		Full Range	15			
CMRR Common-mode rejection ratio	$V_{CC}=5V$ to MAX, $V_{IC}=V_{ICR}min$	25°C	65	80		dB
K_{svr} Supply voltage rejection ratio($\Delta V_{CC}\Delta V_{IO}$)	$V_{CC}=5V$ to MAX	25°C	65	100		dB
V_O1/V_O2 Crosstalk attention	f=1kHz to 20kHz	25°C		120		dB
I_O Output Current	$V_{CC}=15V$, $V_{ID}=1V$, $V_O=0$	25°C	-20	-30		mA
		Full range	-10			
	$V_{CC}=15V$, $V_{ID}=-1V$, $V_O=15V$	25°C	10	20		
		Full range	5			
	$V_{ID}=-1V$, $V_O=200mV$	25°C	12	30		μA
I_{OS} Short -circuit output current	V_{CC} at 5V, GND at -5V, $V_O=0$	25°C		± 40	± 60	mA
I_{CC} Supply current	$V_O=2.5V$, No Load	Full Range		0.7	1.2	mA
	$V_{CC}=MAX$, $V_O=0.5V_{CC}$, No load	Full range		1.1	3	

*All characteristics are measured under open loop conditions with zero common-mode input voltage unless otherwise specified. "MAX" V_{CC} for testing purposes is 30V. Full range is 0°C to 70°C.



APPLICATION HINTS

The LM324 Op amps which operate with only a single supply voltage, have true-differential inputs, and remain in the linear mode with an input common-mode voltage of 0 V_{DC}. These amplifiers operate over a wide range of power supply voltages with little change in performance characteristics.

Precautions should be taken to insure that the power supply for the intergrated circuit never becomes reversed in polarity or that the unit is not inadvertently installed backwards in a test socket as an unlimited current surge through the resulting forward diode within the IC could cause fusing of the internal conductors and result in a destroyed unit.

Large differential input voltages can be easily accommodated and as input differential voltage protection diodes are not needed, no large input currents result from large differential input voltages. The differential input voltages from going negative more than -0.3V_{DC}(25 °C). An input clamp diode with a resistor to the IC input terminal could be used.

The circuits presented in the section on typical applications emphasize operation on only a single power supply voltage. If complementary power supplies are available, all of the standard op-amp circuits can be used. In general, introducing a pseudo-ground(a bias voltage reference of V+/2) will allow operation above and below this value in single power supply systems. Many applications circuits are shown which take advantage of the wide input common-mode voltage range, which includes ground. In most cases, input biasing is not required and input voltages which range to ground can easily be accommodated.

TYPICAL APPLICATIONS

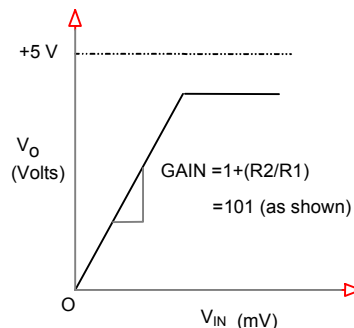
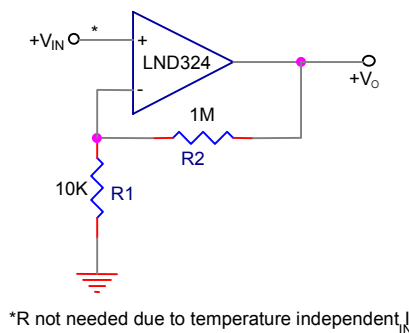

Non Inverting DC Gain (0 V Output)

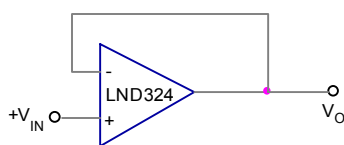

VOLTAGE FOLLOWER

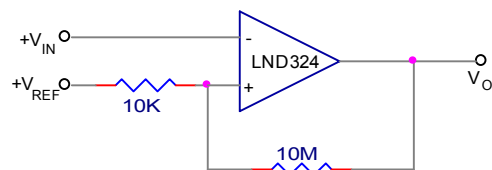

COMPARATOR WITH HYSTERESIS

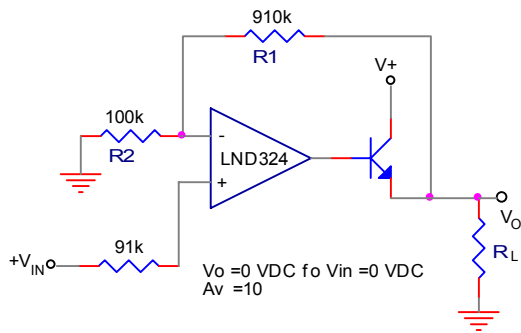

POWER AMPLIFIER

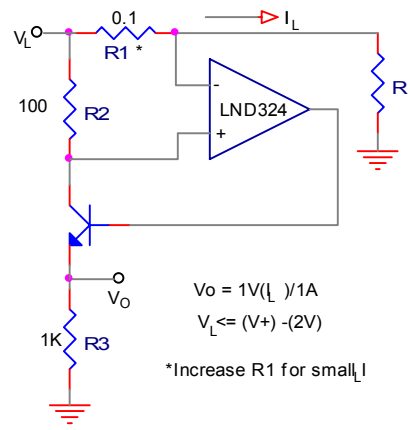

CURRENT MONITOR

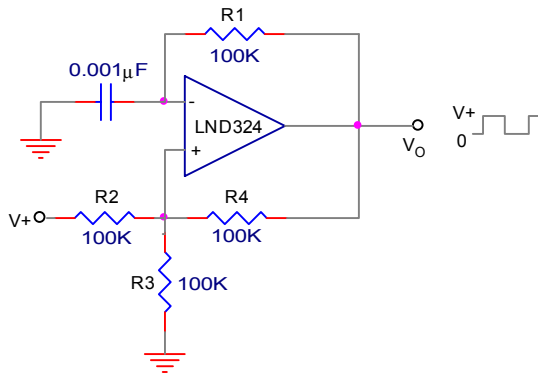

SQUAREWAVE OSCILLATOR

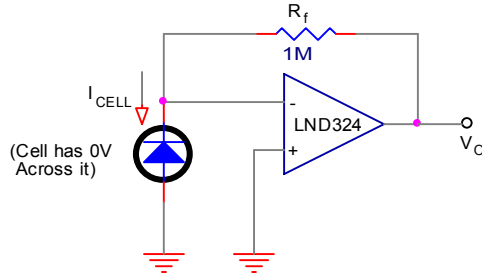
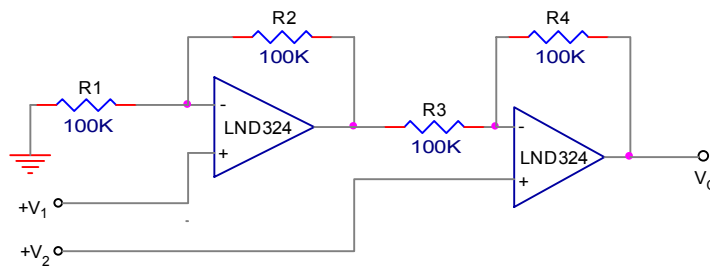
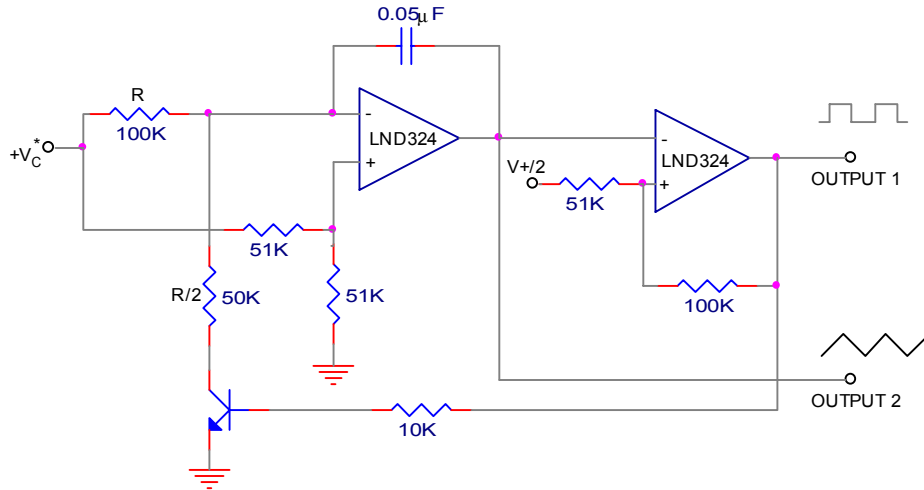

PHOTO VOLTAIC-CELL AMPLIFIER



HIGH INPUT Z, DC DIFFERENTIAL AMPLIFIER



* Wide Control Voltage Range : $0 \text{ VDC} \leq V_c \leq 2 (V - 1.5 \text{ VDC})$

VOLTAGE CONTROLLED OSCILLATOR