

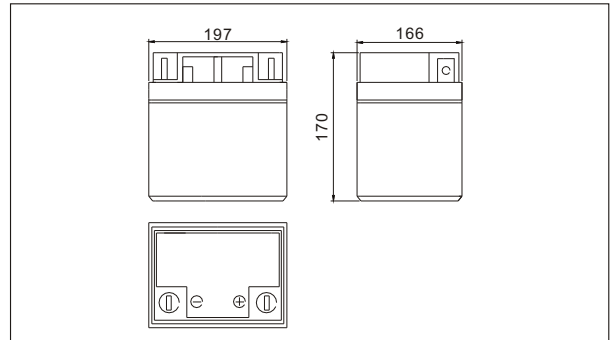

SW12400E (12V40AH)



Outer dimensions (mm)



Specifications

Nominal Voltage		12V
Rated capacity (10 hour rate)		40 Ah
Dimensions	Total Height	170 mm (6.69 inches)
	Height	170 mm (6.69 inches)
	Length	197 mm (7.76 inches)
	Width	166mm (6.54 inches)
Weight Approx		13.5 Kg (29.74 lbs)

Terminal Type (mm)

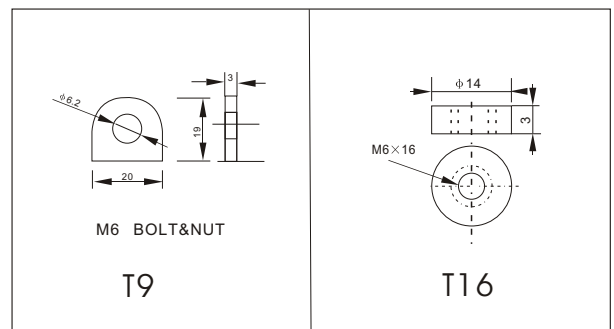

Characteristics

Capacity 25°C(77°F)	10 hour rate(4.0 A)	40.0 AH
	5 hour rate(6.4 A)	32.0 AH
	1 hour rate(22 A)	22.0 AH
	1.5 hour discharge to 10.5V	16 A
Internal Resistance	Full charged Battery at 25°C(77°F)	8mΩ
Capacity affected by Temperature (10hour rate)	40°C(104°F)	102%
	25°C(77°F)	100%
	0°C(32°F)	85%
	-15°C(5°F)	65%
Self-Discharge at 25°C(77°F)	Capacity after 3 month storage	91%
	Capacity after 6 month storage	82%
	Capacity after 12 month storage	64%
Terminal		T9、T16
Charge (constant Voltage)	Cycle	Initial Charging Current less than 10 A Voltage 14.10-14.40V
	Float	Voltage 13.50-13.80V

Discharge Curves 25°C(77°F)

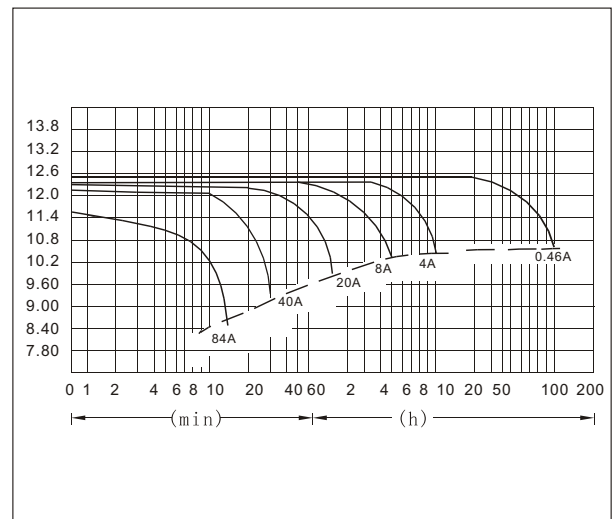

Constant Current(Amp) and Constant Power(Watt) Discharge Table at 25°C(77°F)

Time		10min	30min	1h	3h	4h	5h	8h	10h	20h	50h	100h
9.60V	A	84	46	24	10.3	8.0	6.6	4.7	4.2	2.27	0.94	0.48
	W	937	489	278	119	93	76	54	49	26.3	11.2	5.8
10.20V	A	82	44	22.6	10.0	7.8	6.5	4.6	4.1	2.21	0.91	0.47
	W	901	484	261	116	90	75	53	47	25.6	10.8	5.6
10.50V	A	78	42	22	9.8	7.7	6.4	4.5	4.0	2.18	0.90	0.46
	W	874	457	253	113	89	74	52	47	25.3	10.7	5.5
10.80V	A	73	41	21	9.5	7.6	6.2	4.4	3.9	2.16	0.88	0.46
	W	840	440	242	111	87	73	51	47	25.1	10.5	5.4
11.10V	A	67	38	20	9.2	7.3	6.1	4.3	3.80	2.05	0.86	0.44
	W	825	436	235	109	87	72	51	45	24.4	10.3	5.2