

SKY65329-NP: 900 MHz Front-End Module

Applications

- Paging
- Remote metering
- WLL and ISM transmitters

Features

- 900 MHz transmit saturated output power > 24 dBm
- 900 MHz high efficiency PA and LNA
- Auxiliary bidirectional broadband RF path
- Internal switching and control circuits
- Internal RF match and bias circuits
- Internal DC block on RF ports
- Externally adjustable bias setting
- Single DC supply = 3.6 V
- Small footprint, MCM (28-pin, 8 x 8 mm) Pb-free (MSL3, 260 °C per JEDEC J-STD-020) SMT package

NEW



Skyworks Green™ products are RoHS (Restriction of Hazardous Substances)-compliant, conform to the EIA/EICTA/JEITA Joint Industry Guide (JIG) Level A guidelines, are halogen free according to IEC-61249-2-21, and contain <1,000 ppm antimony trioxide in polymeric materials.

Description

Skyworks SKY65329-NP is a fully matched, high-efficiency RF Front-End Module (FEM) with 900 MHz transmit and receive paths. There are also routing switches to connect auxiliary broadband signals between the RFIC and antenna ports. By using three control signals (CTRL1, CTRL2, and PWR_DOWN), the module can be configured to one of five operational modes (900 MHz transmit, 900 MHz receive, auxiliary RF bypass, auxiliary power, or power down).

The 900 MHz transmit path consists of an harmonic filter and high efficiency Power Amplifier (PA). The 900 MHz receive path contains a low-power Low-Noise Amplifier (LNA). Both the PA and LNA can be switched to power-down mode for low leakage current. The auxiliary RF path is a low-loss, broadband, bidirectional RF path that allows easy switching of signal between the RFIC and the antenna port.

Breakout ports are available for adding external filters. Switchable auxiliary power can supply up to 10 mA of VDD power to external circuitry through pin 26 (VDD_OUT).

The SKY65329-NP is manufactured with advanced InGaP HBT and silicon CMOS processes, which provide a positive DC voltage supply while maintaining high efficiency and good linearity.

The device is mounted in a 28-pin, 8 x 8 mm MCM Surface-Mounted Technology (SMT) package, which allows for a highly manufacturable low-cost solution.

A block diagram of the SKY65329-NP is shown in Figure 1. The device package and pinout for the 28-pin MCM are shown in Figure 2.

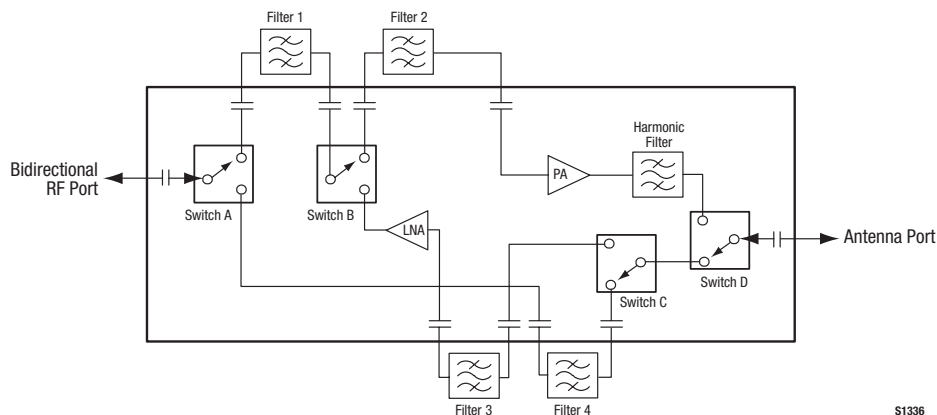

Figure 1. SKY65329-NP Block Diagram

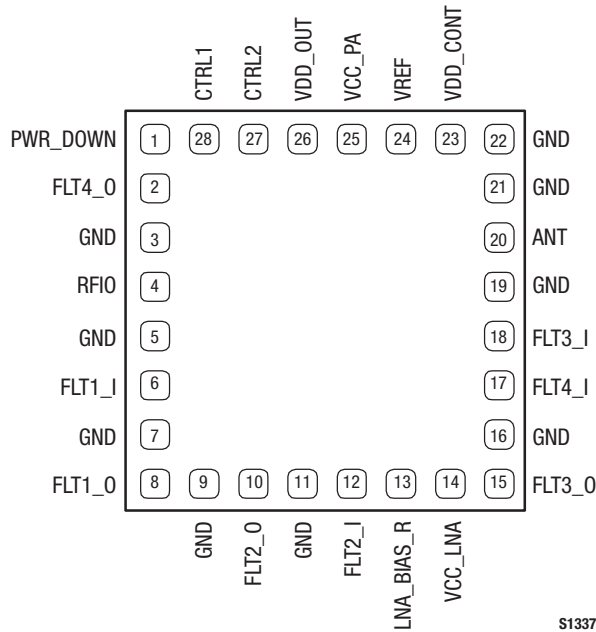

Figure 2. SKY65329-NP Pinout – 28-Pin MCM (Top View)

Table 1. SKY65329-NP Control Logic

| Configuration | Logic Input Control Bits | | | States | | |
|---------------------|--------------------------|-------|----------|--------|-----|------------|
| | CTRL1 | CTRL2 | PWR_DOWN | PA | LNA | VDD Output |
| Auxiliary power | 0 | 0 | 0 | Off | Off | On |
| 900 MHz receive | 0 | 1 | 0 | Off | On | Off |
| 900 MHz transmit | 1 | 0 | 0 | On | Off | Off |
| Auxiliary RF bypass | 1 | 1 | 0 | Off | Off | Off |
| Power down | X | X | 1 | Off | Off | Off |

Note: Logic level 0: 0 V to 0.3 V
 Logic level 1: 2.5 V to VCC.

Technical Description

The SKY65329-NP provides input and output amplifier stages and is internally matched for optimum efficiency. An active bias circuit provides both input and output stages with excellent gain tracking over temperature and voltage variations. The module operates with positive DC voltages, and maintains high efficiency and good linearity. The nominal operating voltage is 3.6 V for maximum power, but the device can be operated at slightly lower voltages for other mobile applications.

Operational Modes

By using three control signals (CTRL1, CTRL2, and PWR_DOWN), the module can be configured to one of five operational modes:

Auxiliary power. In this mode, the PA and LNA are off and the VDD_OUT signal (pin 26) can be used for auxiliary power, which can supply up to 10 mA of VDD power to external circuitry.

900 MHz receive. In this mode, the SKY65329-NP amplifies the received signal at the antenna port through the LNA.

900 MHz transmit. In this mode, the transmit path provides an harmonic filter and high efficiency PA.

Auxiliary RF bypass. In this mode, a low-loss broadband bidirectional RF path allows easy switching of the signal between the transceiver and the antenna port.

Power down. In this mode, the PA and LNA are powered down for minimal current consumption and low leakage current (5 µA).

Table 1 provides the control logic for each of the five operational modes.

Electrical and Mechanical Specifications

Signal pin assignments and functional pin descriptions are described in Table 2. The absolute maximum ratings of the SKY65329-NP are provided in Table 3. The recommended operating conditions are specified in Table 4 and electrical specifications are provided in Table 5.

Package and Handling Information

Since the device package is sensitive to moisture absorption, it is baked and vacuum packed before shipping. Instructions on the shipping container label regarding exposure to moisture after the container seal is broken must be followed. Otherwise, problems

related to moisture absorption may occur when the part is subjected to high temperature during solder assembly.

The SKY65329-NP is rated to Moisture Sensitivity Level 3 (MSL3) at 260 °C. It can be used for lead or lead-free soldering. For additional information, refer to Skyworks Application Note, *PCB Design and SMT Assembly/Rework Guidelines for MCM-L Packages*, document number 101752.

Care must be taken when attaching this product, whether it is done manually or in a production solder reflow environment. Production quantities of this product are shipped in a standard tape and reel format. For packaging details, refer to the Skyworks Application Note, *Tape and Reel*, document number 101568.

Table 2. SKY65329-NP Signal Descriptions

| Pin # | Name | Description | Pin # | Name | Description |
|-------|------------|---|-------|----------|--------------------------------------|
| 1 | PWR_DOWN | Power down | 15 | FLT3_O | Filter 3 output port |
| 2 | FLT4_O | Filter 4 output port | 16 | GND | Ground |
| 3 | GND | Ground | 17 | FLT4_I | Filter 4 input port |
| 4 | RFIO | RF input/output (internally DC blocked) | 18 | FLT3_I | Filter 3 input port |
| 5 | GND | Ground | 19 | GND | Ground |
| 6 | FLT1_I | Filter 1 input port | 20 | ANT | Antenna port (internally DC blocked) |
| 7 | GND | Ground | 21 | GND | Ground |
| 8 | FLT1_O | Filter 1 output port | 22 | GND | Ground |
| 9 | GND | Ground | 23 | VDD_CONT | CMOS controller supply voltage |
| 10 | FLT2_O | Filter 2 output port | 24 | VREF | PA bias reference voltage |
| 11 | GND | Ground | 25 | VCC_PA | PA collector voltage |
| 12 | FLT2_I | Filter 2 input port | 26 | VDD_OUT | Auxiliary supply |
| 13 | LNA_BIAS_R | LNA bias resistor | 27 | CTRL2 | Control 2 |
| 14 | VCC_LNA | LNA collector voltage | 28 | CTRL1 | Control 1 |

Table 3. SKY65329-NP Absolute Maximum Ratings (Note 1)

| Parameter | Symbol | Minimum | Maximum | Units |
|----------------------------|--------------------|---------|---------|-------|
| Supply voltage | VCC | | 4 | V |
| Transmit input power | P _{IN_TX} | | | dBm |
| Receive input power | P _{IN_RX} | | | dBm |
| Supply current | I _{CC} | | | mA |
| Power dissipation | P _{DISS} | | | W |
| Case operating temperature | T _C | -40 | +85 | °C |
| Storage temperature | T _{ST} | -55 | +125 | °C |
| Junction temperature | T _J | | +150 | °C |

Note 1: Exposure to maximum rating conditions for extended periods may reduce device reliability. There is no damage to device with only one parameter set at the limit and all other parameters set at or below their nominal value.

Table 4. SKY65329-NP Recommended Operating Conditions

| Parameter | Symbol | Minimum | Typical | Maximum | Units |
|----------------------------|------------------|---------|---------|---------|-------|
| Supply voltage | VCC | 2.8 | 3.6 | 3.8 | V |
| Frequency range | f | 902 | | 928 | MHz |
| Auxiliary frequency range | f _{AUX} | 400 | | 2500 | MHz |
| Transmit input power range | P _{IN} | -3 | | -1 | dBm |
| Case operating temperature | T _C | -40 | | +85 | °C |
| Storage temperature | T _{ST} | -55 | | +125 | °C |

Table 5. SKY65329-NP Electrical Specifications
(VCC = 3.6 V, Tc = +25 °C, External PA VCC Bias Resistor [R28] = 2 kΩ, Unless Otherwise Noted)

| Parameter | Symbol | Test Condition | Min | Typical | Max | Units |
|--|-----------------------|--|-----------|---------|-----|-------|
| General | | | | | | |
| Return loss | RL | All RF ports except ANT in transmit mode, 50 Ω | 12 | | | dB |
| Thermal resistance | Θ _{JC} | | | 22 | | °C/W |
| Auxiliary Power Mode | | | | | | |
| Auxiliary power | VCC Ext | Load current < 10 mA | VCC - 0.1 | | VCC | V |
| 900 MHz Receive Mode (0 Ω Between FLT1_1/FLT1_0 and FLT3_1/FLT3_0 Pins in Place of External Filters) | | | | | | |
| Small signal gain | G _{SS} (Rx) | CW | | 18.5 | | dB |
| Noise Figure | NF (Rx) | | | 2.0 | | dB |
| Input 1dB compression | IP1dB (Rx) | CW | | -13 | | dBm |
| Input IP3 | IIP3 | Two -30 dBm CW tones | | -2 | | dBm |
| Operating current | I _{OP} (Rx) | P _{OUT} = IP1dB (Rx) | | 4.5 | | mA |
| 900 MHz Transmit Mode (0 Ω Between FLT1_1/FLT1_0 and FLT2_1/FLT2_0 Pins in Place of External Filters) | | | | | | |
| Saturated output power | P _{SAT} | CW, P _{IN} = -3 dBm | +21.0 | +24.3 | | dBm |
| | | CW, P _{IN} = -1 dBm | | +24.9 | | dBm |
| Saturated output power cold droop (Note 1) | D _{PSATCold} | CW, VCC = 2.8 V, T _C = -40 °C | | 2 | 3 | dB |
| Small signal gain | G _{SS} (Tx) | CW | | 28 | | dB |
| Noise Figure | NF (Tx) | CW | | 7.5 | | dB |
| Power Added Efficiency | PAE | CW, P _{IN} = -3 dBm | | 48.0 | | % |
| | | CW, P _{IN} = -1 dBm | | 48.6 | | % |
| 2 nd harmonic | Pf2 | CW, P _{IN} = -3 dBm | | -39 | -30 | dBc |
| 3 rd to 8 th harmonic | Pf3 to Pf8 | CW, P _{IN} = -3 dBm | | -66 | -60 | dBc |
| Operating current | I _{OP} (Tx) | CW, P _{IN} = -3 dBm | | 150 | | mA |
| | | CW, P _{IN} = -1 dBm | | 167 | | mA |
| Output return loss | ORL (Tx) | CW, P _{IN} = -3 dBm | 8 | | | dB |
| Auxiliary RF Bypass Mode (0 Ω Between FLT4_1 and FLT4_0 Pins in Place of External Filters) | | | | | | |
| 450 MHz loss | IL (Aux) | f = 450 MHz | | 1.5 | 2.5 | dB |
| FEM Power-Down Mode | | | | | | |
| Leakage current | I _{LEAK} | No RF input | | 0.2 | | μA |

Note 1: Saturated transmit output power cold droop is defined as the drop in P_{SAT} at VCC = 2.8 V and T_C = -40 °C relative to P_{SAT} at VCC = 3.6 V and T_C = +25 °C.

Evaluation Board Description

The SKY65329-NP Evaluation Board is used to test the performance of the SKY65329-NP FEM. The Evaluation Board schematic diagram is shown in Figure 3. An assembly drawing for the Evaluation Board is shown in Figure 4 and the layer detail is provided in Figure 5. The layer detail physical characteristics are noted in Figure 6. Table 6 provides the Bill of Materials (BOM) list for Evaluation Board components.

The four external filters shown in Figure 3 are configured as throughputs so that the device can be tested immediately. External resistors are installed with values that allow the unit to operate immediately with the electrical specifications provided in Table 4. Refer to the *SKY65329 T/R FEM Evaluation Board Information Application Note* (document # *** TBD ***) for additional testing information.

The digital ground pin of the SKY65329-NP (pin 22) is not connected to the other ground pins internally. Therefore, an external common ground connection is needed. If this is not provided, the digital controller may operate at a different potential than the RF section, which could damage the part.

The separate digital ground pin allows flexibility when connecting the ground between the digital and RF sections of the device. This connection is through resistor R21 and capacitor C11 (loaded with a 0 Ω resistor by default). If RF isolation is desired between the digital and RF sections, an appropriate component may be placed instead. Pin 16 of connector P1 is used to connect the source of the digital controls to a common ground point with the test fixture through components R21 and C11.

Circuit Design Considerations

The following design considerations are general in nature and must be followed regardless of final use or configuration:

1. Paths to ground should be made as short as possible.

2. The ground pads of the SKY65329-NP have special electrical and thermal grounding requirements. These pads are the main thermal conduit for heat dissipation. Since the circuit board acts as the heat sink, it must shunt as much heat as possible from the device. Therefore, design the connection to the ground pad to dissipate the maximum wattage produced by the circuit board. Multiple vias to the grounding layer are required.
3. Two external output bypass capacitors (0.022 μF and 22 μF) are required on pin 25 (VCC_PA). The same two capacitor values are also required on pin 14 (VCC_LNA). The capacitors should be placed in parallel between the supply line and ground.
4. Pins 14 and 25 (VCC_LNA and VCC_PA, respectively) may be connected together at the supply.

NOTE: A poor connection between the slug and ground increases junction temperature (T_J), which reduces the lifetime of the device.

Package Dimensions

The phone board layout footprint for the SKY65329-NP is shown in Figure 7. Package dimensions for the 28-pin MCM are shown in Figure 8, and tape and reel dimensions are provided in Figure 9.

Electrostatic Discharge (ESD) Sensitivity

The SKY65329-NP is a static-sensitive electronic device. Do not operate or store near strong electrostatic fields. Take proper ESD precautions.

PRELIMINARY DATA SHEET • SKY65329-NP TRANSMIT/RECEIVE FRONT-END MODULE

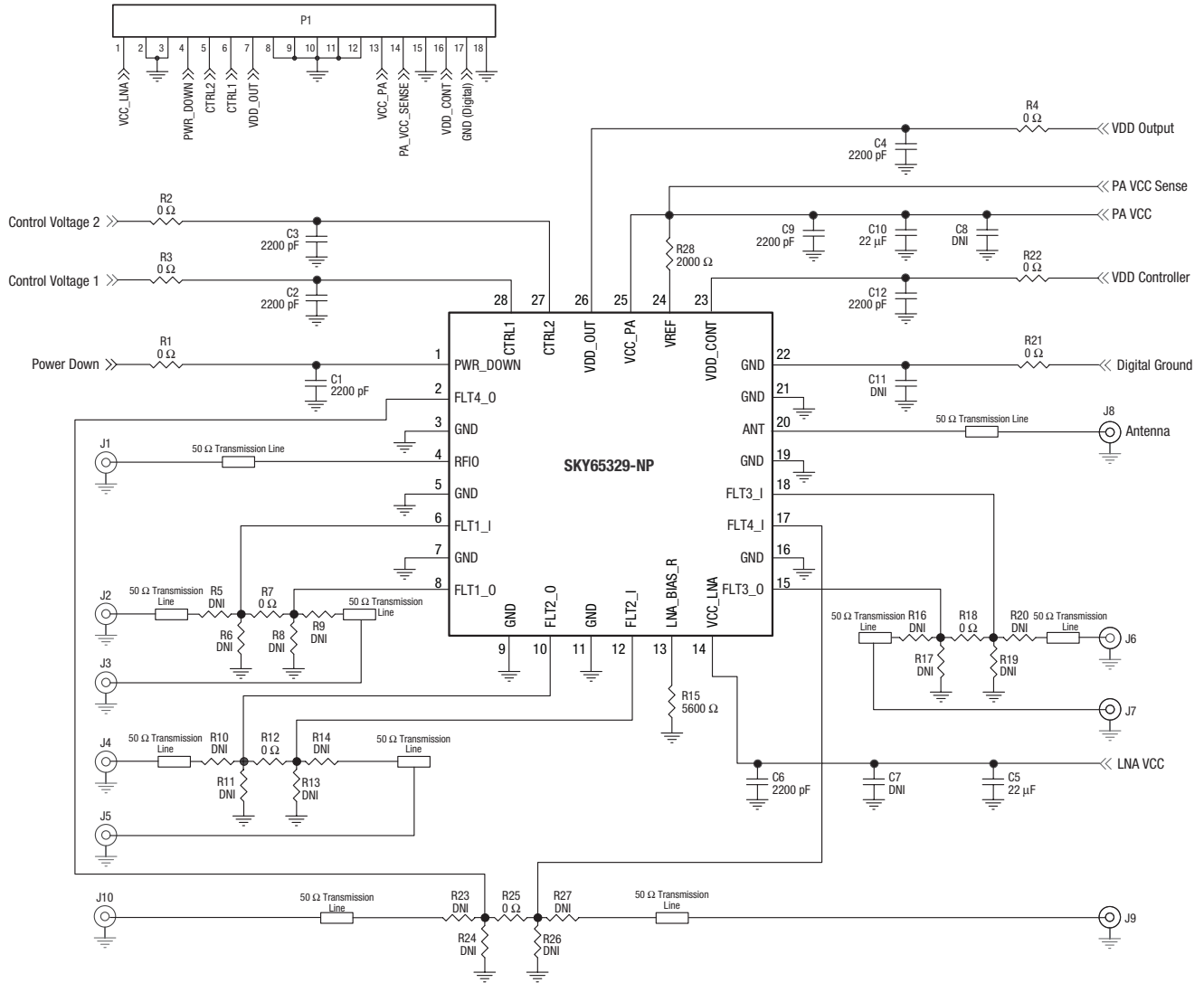

Note: Some component labels may be different than the corresponding component symbol shown here. Component values, however, are accurate as of the date of this Data Sheet.

S1342

Figure 3. SKY65329-NP Evaluation Board Schematic

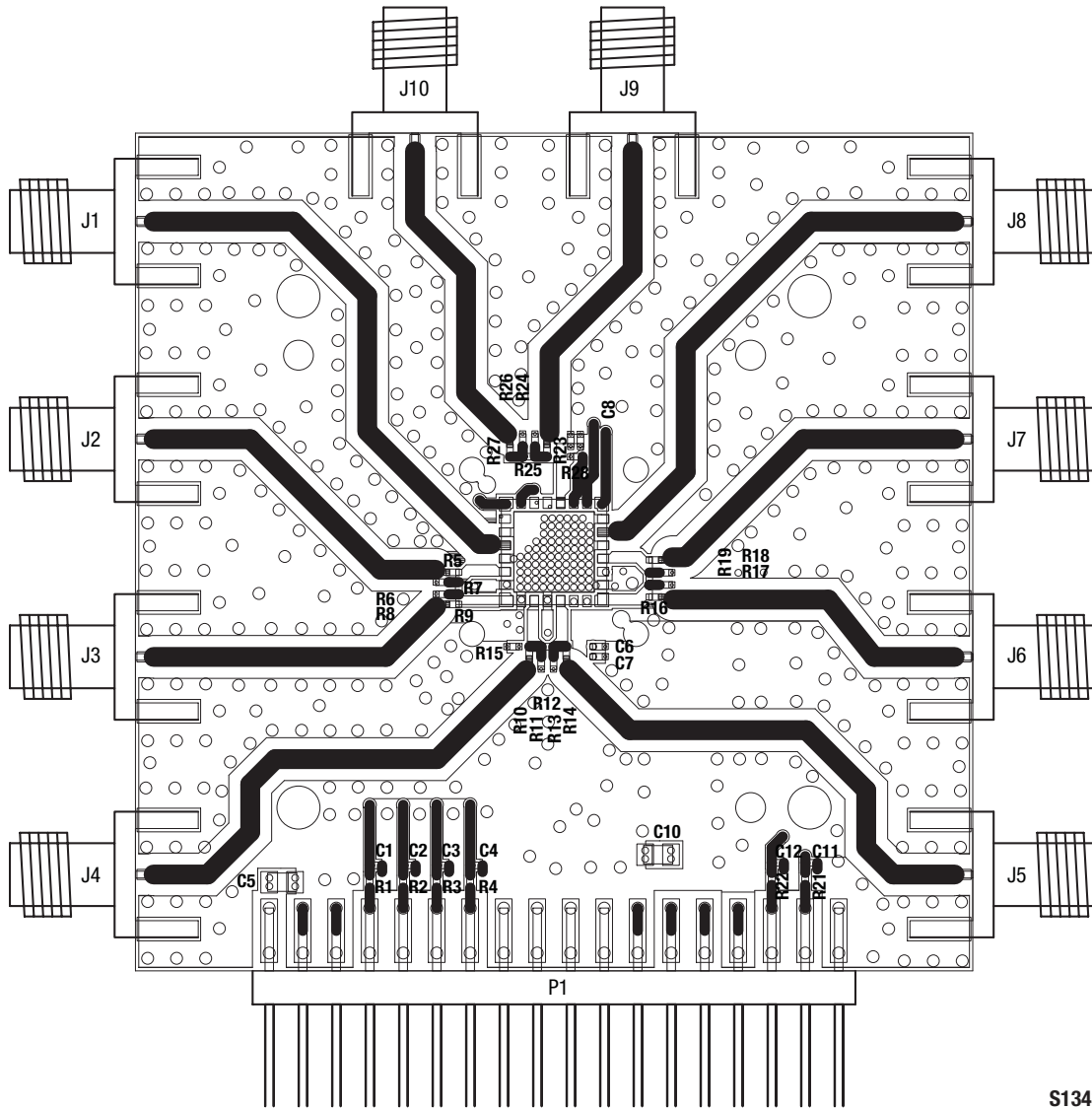
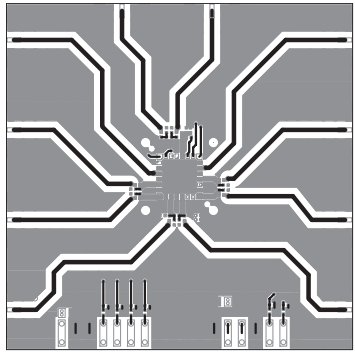
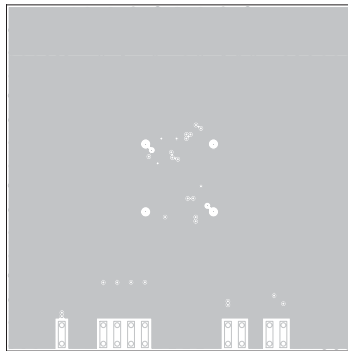

Figure 4. SKY65329-NP Evaluation Board Assembly Drawing

S1343



Layer 1: Top – Metal



Layer 2: Ground

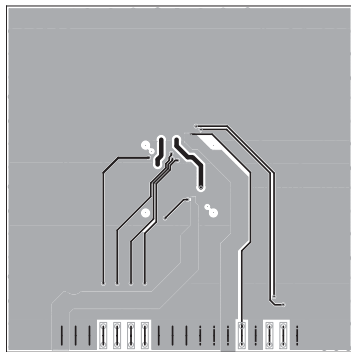

Layer 3: Power Plane

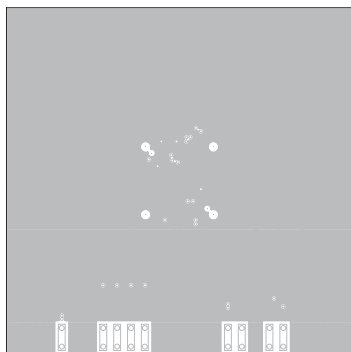

Layer 4: Solid Ground Plane

S1344

Figure 5. SKY65329-NP Evaluation Board Layer Detail

PRELIMINARY DATA SHEET • SKY65329-NP TRANSMIT/RECEIVE FRONT-END MODULE

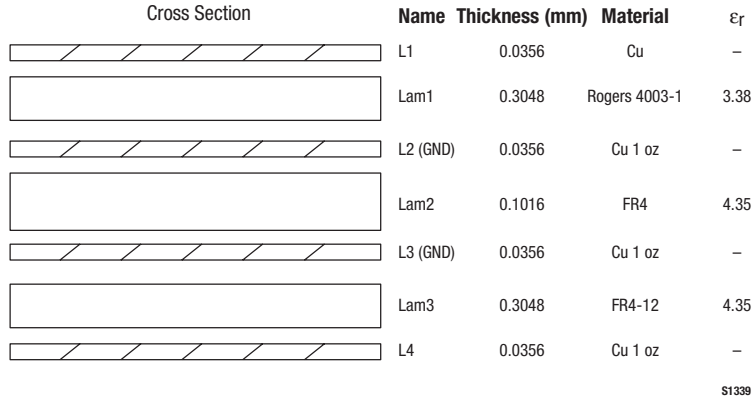
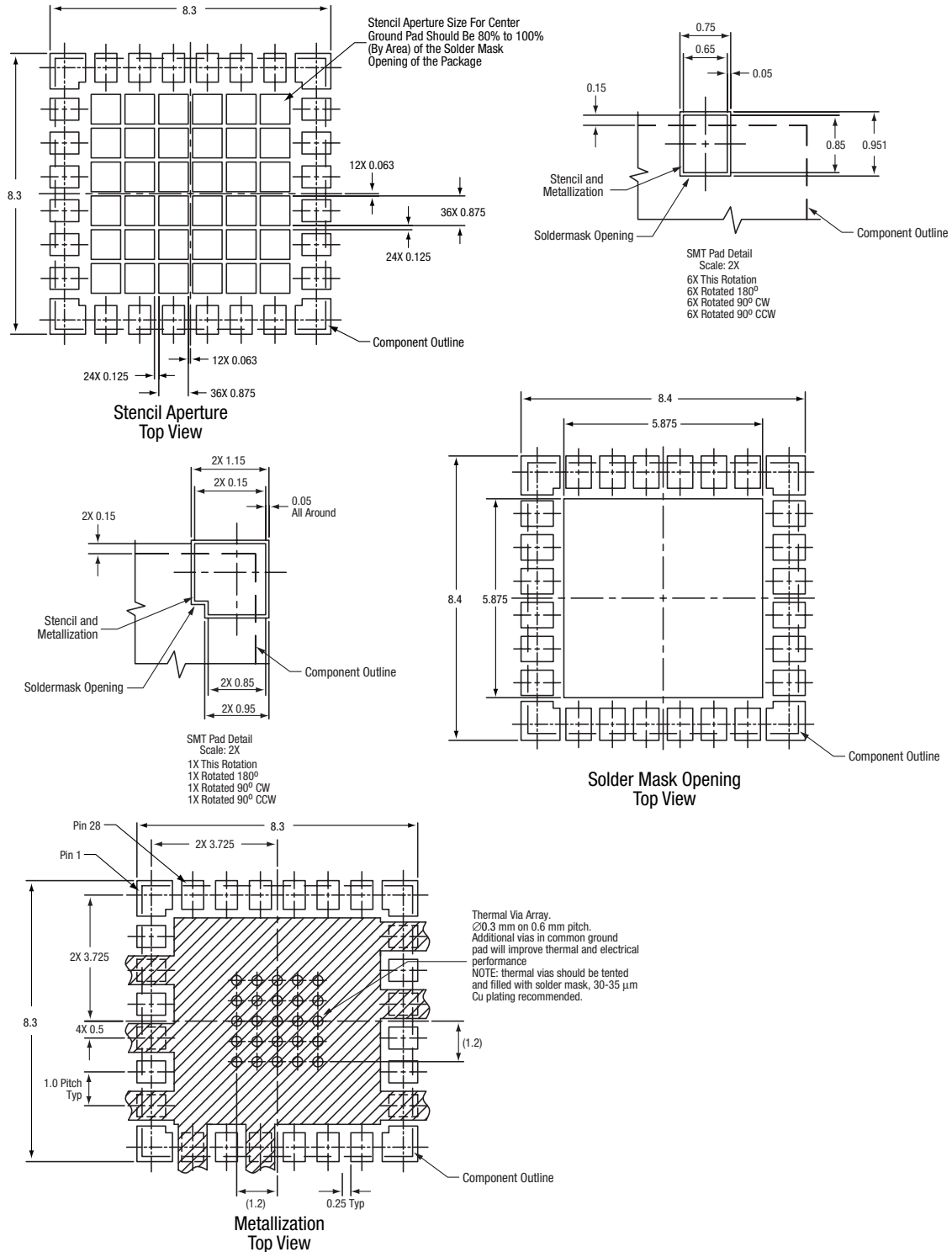

Figure 6. Layer Detail Physical Characteristics

Table 6. SKY65329-NP Evaluation Board Bill of Materials

| Component | Quantity | Size | Value | Vendor | Part Number |
|---|----------|------|---------------|--------|-------------------|
| C1, C2, C3, C4, C6, C9, C12 | 7 | 0402 | 2200 pF | Murata | GRM155R71H222KA01 |
| C5, C10 | 2 | 0805 | 22 μ F | Murata | GRM21BR60J226KA11 |
| R1, R2, R3, R4, R7, R12, R18, R21, R22, R25 | 10 | 0402 | 0 Ω | Yageo | RC0402JR-*18RL |
| R28 | 1 | 0402 | 2000 Ω | Yageo | RC0402JR-*2KL |
| R15 | 1 | 0402 | 5600 Ω | Yageo | RC0402JR-*5K6L |
| C7, C8, C11, R5, R6, R8, R9, R10, R11, R13, R14, R16, R17, R19, R20, R23, R24, R26, R27 | 19 | N/A | DNI | N/A | N/A |

PRELIMINARY DATA SHEET • SKY65329-NP TRANSMIT/RECEIVE FRONT-END MODULE



Note: The cross-hatched area represents the merger of the center ground pad +8 individual I/O ground pads. All I/O ground pads should have at least one via connected to internal ground planes for optimum electrical performance.

All measurements are in millimeters

S1340

Figure 7. SKY65329-NP Phone Board Layout Footprint

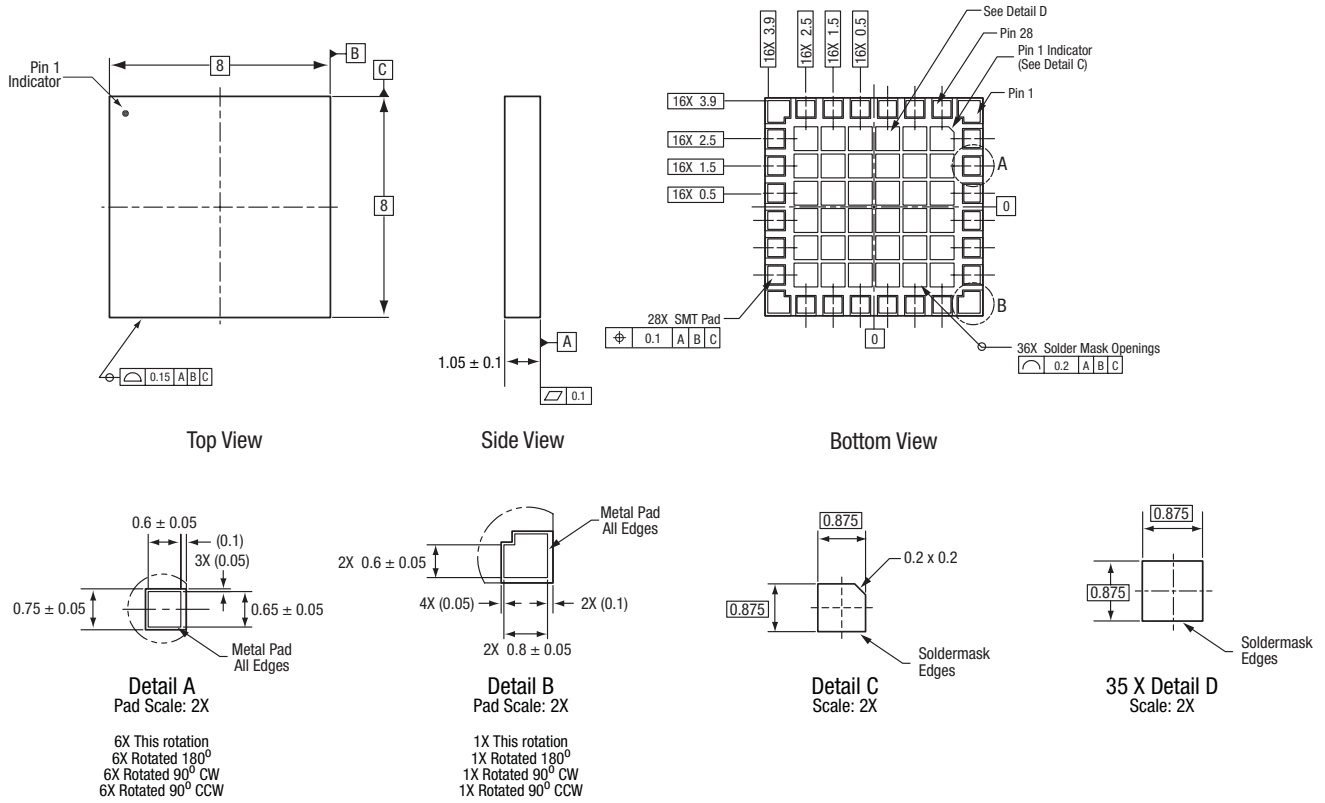

All measurements are in millimeters

Dimensioning and tolerancing according to ASME Y14.5M-1994

S1341

Figure 8. SKY65329-NP 28-Pin MCM Package Dimensions

PRELIMINARY DATA SHEET • SKY65329-NP TRANSMIT/RECEIVE FRONT-END MODULE

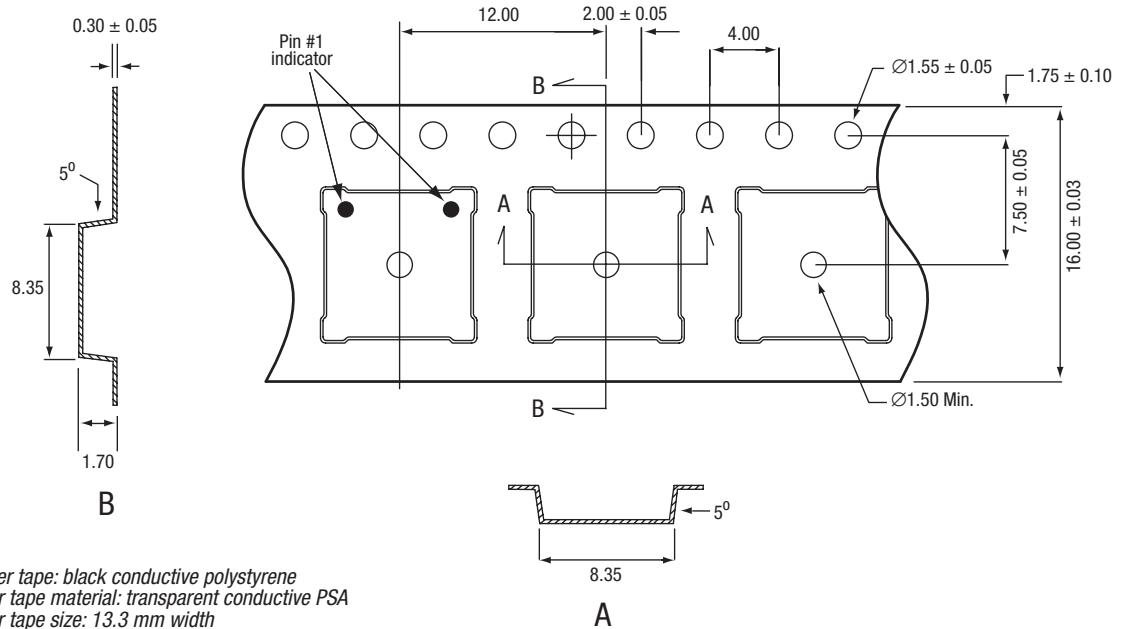

Notes:

1. Carrier tape: black conductive polystyrene
2. Cover tape material: transparent conductive PSA
3. Cover tape size: 13.3 mm width
4. All dimensions are in millimeters
5. Pin 1 orientation is in top left corner for the following Skyworks products:

SKY74963-xx
 CX74063-35
 SKY77503-xx
 SKY77506-xx
 SKY77512-xx
 SKY77526-xx
 SKY77343-xx

For all other 8 x 8 mm MCM/RFLGA products, pin 1 orientation is in top right corner.

S1290

Figure 9. SKY65329-NP 28-Pin MCM Tape and Reel Dimensions

Ordering Information

| Model Name | Manufacturing Part Number | Evaluation Kit Part Number |
|--------------------------------------|-------------------------------|----------------------------|
| SKY65329-NP 900 MHz Front-End Module | SKY65329-NP (Pb-free package) | TW17-D390 |

Copyright © 2009 Skyworks Solutions, Inc. All Rights Reserved.

Information in this document is provided in connection with Skyworks Solutions, Inc. (“Skyworks”) products or services. These materials, including the information contained herein, are provided by Skyworks as a service to its customers and may be used for informational purposes only by the customer. Skyworks assumes no responsibility for errors or omissions in these materials or the information contained herein. Skyworks may change its documentation, products, services, specifications or product descriptions at any time, without notice. Skyworks makes no commitment to update the materials or information and shall have no responsibility whatsoever for conflicts, incompatibilities, or other difficulties arising from any future changes.

No license, whether express, implied, by estoppel or otherwise, is granted to any intellectual property rights by this document. Skyworks assumes no liability for any materials, products or information provided hereunder, including the sale, distribution, reproduction or use of Skyworks products, information or materials, except as may be provided in Skyworks Terms and Conditions of Sale.

THE MATERIALS, PRODUCTS AND INFORMATION ARE PROVIDED “AS IS” WITHOUT WARRANTY OF ANY KIND, WHETHER EXPRESS, IMPLIED, STATUTORY, OR OTHERWISE, INCLUDING FITNESS FOR A PARTICULAR PURPOSE OR USE, MERCHANTABILITY, PERFORMANCE, QUALITY OR NON-INFRINGEMENT OF ANY INTELLECTUAL PROPERTY RIGHT; ALL SUCH WARRANTIES ARE HEREBY EXPRESSLY DISCLAIMED. SKYWORKS DOES NOT WARRANT THE ACCURACY OR COMPLETENESS OF THE INFORMATION, TEXT, GRAPHICS OR OTHER ITEMS CONTAINED WITHIN THESE MATERIALS. SKYWORKS SHALL NOT BE LIABLE FOR ANY DAMAGES, INCLUDING BUT NOT LIMITED TO ANY SPECIAL, INDIRECT, INCIDENTAL, STATUTORY, OR CONSEQUENTIAL DAMAGES, INCLUDING WITHOUT LIMITATION, LOST REVENUES OR LOST PROFITS THAT MAY RESULT FROM THE USE OF THE MATERIALS OR INFORMATION, WHETHER OR NOT THE RECIPIENT OF MATERIALS HAS BEEN ADVISED OF THE POSSIBILITY OF SUCH DAMAGE.

Skyworks products are not intended for use in medical, lifesaving or life-sustaining applications, or other equipment in which the failure of the Skyworks products could lead to personal injury, death, physical or environmental damage. Skyworks customers using or selling Skyworks products for use in such applications do so at their own risk and agree to fully indemnify Skyworks for any damages resulting from such improper use or sale.

Customers are responsible for their products and applications using Skyworks products, which may deviate from published specifications as a result of design defects, errors, or operation of products outside of published parameters or design specifications. Customers should include design and operating safeguards to minimize these and other risks. Skyworks assumes no liability for applications assistance, customer product design, or damage to any equipment resulting from the use of Skyworks products outside of stated published specifications or parameters.

Skyworks, the Skyworks symbol, and “Breakthrough Simplicity” are trademarks or registered trademarks of Skyworks Solutions, Inc., in the United States and other countries. Third-party brands and names are for identification purposes only, and are the property of their respective owners. Additional information, including relevant terms and conditions, posted at www.skyworksinc.com, are incorporated by reference.