

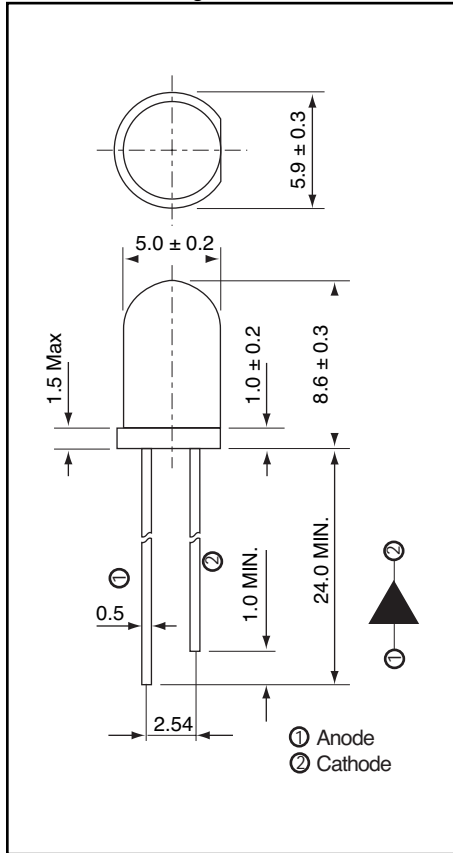

Package Dimensions Unit: mm



# AND157HGP

## InGaAlP High Brightness Green Light Emission

### 5mm (T1-3/4) Package

#### Features

- RoHS Compliant
- High efficiency
- Viewing Angle: 20 degrees
- All plastic mold type, clear colorless lens
- Peak wavelength ( $\lambda_p = 575$  nm)
- ESD-withstand voltage: up to 2KV
- **RoHS Compliant**

#### Applications

- Outdoor Displays
- Status Indicators
- Backlighting
- Commercial Use

#### Maximum Ratings: ( $T_a = 25^\circ\text{C}$ )

Item	Symbol	Rating	Units
Continuous Forward Current	IF	25	mA
Reverse Voltage	VR	5	V
Peak Forward Current (Pulse Width < 100 $\mu$ s, Duty Cycle < 1%)	IFP	100	mA
Operating Temperature	Topr	-40 ~ +85	$^\circ\text{C}$
Storage Temperature	Tstg	-40 ~ +100	$^\circ\text{C}$
Soldering Temperature (Time < 5 sec.)	Tsol	260	$^\circ\text{C}$
Power Dissipation	Pd	60	mW
Electrostatic Discharge	ESD	2000	V

#### Electro-Optical Characteristics ( $T_a = 25^\circ\text{C}$ )

Characteristics	Symbol	Test Condition	Minimum	Typical	Maximum	Unit
Forward Voltage	$V_F$	$I_F = 20$ mA	-	2.0	2.4	V
Reverse Current	$I_R$	$V_R = 5$ V	-	-	10	$\mu\text{A}$
Luminous Intensity	$I_V$	$I_F = 20$ mA	630	1,250	-	mcd
Peak Emission Wavelength	$\lambda_p$	$I_F = 20$ mA	-	575	-	nm
Spectrum Radiation Bandwidth	$\lambda_d$	$I_F = 20$ mA	-	573	-	nm
Dominant Wavelength	$\Delta\lambda$	$I_F = 20$ mA	-	20	-	nm
Viewing Angle	$2\theta$ 1/2	$I_F = 20$ mA	-	20	-	degree

#### Precaution

Please be careful of the following:

1. Soldering temperature: 260 C max., Soldering time: 5 sec. max.  
Soldering portion of lead: up to 1.6 mm from the body of the device.

Product specifications contained herein may be changed without prior notice. It is therefore advisable to contact Purdy Electronics before proceeding with the design of equipment incorporating this product.

