

High-performance System Video Driver Series



Wide Band 3-output Video Driver

BH7600AFS, BH7601FS, BH7602FS

No.09065EAT05

● Description

BH7600AFS, BH7601FS and BH7602FS is wide band 3-output video driver for high-definition television system. This video driver is built in the DC output circuits (LINE1, LINE2, LINE3 output) for D terminal and detector to connect. And they have line-up build in sync-mix, DC shift input, selectable LPF every applications.

● Features

- 1) Built-in the DC output circuits (LINE1, LINE2, LINE3) / detector to connect.
- 2) Built-in OUTPUT MUTE circuit
- 3) I²C BUS control
- 4) Pedestal clamp input with sync mix (BH7600AFS)
- 5) Sync tip clamp input 1ch, bias input 2ch (BH7601FS)
- 6) Possible to be directly connected with DAC by DC shift circuit (BH7602FS)
- 7) Built-in power down function (BH7602FS)

● Applications

DVD Player, DVD Recorder, DVC, DSC, STB, TV and so on.

● Line Up

Parameter	BH7600AFS	BH7601FS	BH7602FS
Input form of Py	Pedestal Clamp With sync mix	Sync tip Clamp	DC Shift (Directly connected)
Input form of Pb, Pr	Pedestal Clamp	Bias Input	DC Shift (Directly connected)
Voltage Gain	5.5dB	8.45dB	6.0dB
Package	SSOP-A24	SSOP-A24	SSOP-A20

● Absolute Maximum Ratings (Ta=25°C)

Parameter	Symbol	Rating	Unit
Supply Voltage	V _{CC}	7	V
Power Dissipation	P _d	800 (SSOP-A24) 750 (SSOP-A20)	mW
Input Voltage Range	V _{in}	0~V _{CC}	V
Operating Temperature	T _{opr}	-25~+75 (SSOP-A24) -35~+75 (SSOP-A20)	°C
Storage Temperature	T _{stg}	-55~+125	°C

※1. 70mm×70mm×1.6mm mounting on the glass epoxy board.

※2. For operation above Ta=25°C free-air temperature, power dissipation is decreasing
8.0mW/°C(SSOP-A24), 7.5mW/°C (SSOP-A20).

● Operating Voltage Range

Parameter	Symbol	Min	Typ	Max	Unit
Supply Voltage (BH7600AFS/BH7601FS)	V _{CC}	4.5	5.0	5.5	V
Supply Voltage (BH7602FS)	V _{CC}	4.5	5.0	5.25	V

● BH7600AFS

Electrical Characteristics (Unless otherwise specified, Ta=25°C, V_{CC}=5V)

Parameter	Symbol	Min	Typ	Max	Unit	Conditions
《All Circuits》						
Circuit Current	I _{CC}	10.8	21.5	32.3	mA	No Signal
LINEOUT Γ _H Voltage	V _{LOH}	4.0	4.9	5.0	V	
LINEOUT Γ _M Voltage	V _{LOM}	1.5	1.9	2.3	V	
LINEOUT Γ _L Voltage	V _{LOL}	0.0	0.2	0.5	V	
LINEOUT Impedance	Z _{LO}	1.3	1.8	2.3	kΩ	
《Video Driver Parts》						
Voltage Gain	G _V	-1	-0.5	0	dB	V _{IN} =1V _{P-P} , f=1MHz ※1
Frequency Characteristics 1	V _{F1}	-1	0	1	dB	V _{IN} =1V _{P-P} , f=1M/10MHz
MUTE Input Parts Impedance	Z _{IN}	75	100	125	kΩ	
MUTE Γ _H Level Input Voltage	V _{MH}	2.0	-	V _{CC}	V	
MUTE Γ _L Level Input Voltage	V _{ML}	0	-	1.0	V	
《SYNC》						
SYNC1, 2 Γ _H Level Input Voltage	V _{SYNH}	2.0	-	V _{CC}	V	
SYNC1, 2 Γ _L Level Input Voltage	V _{SYNL}	0	-	1.0	V	
SYNC Input Bias Current	I _{SYN}	0	-2.0	20	μA	
SYNC Mix Level	V _{SYL}	270	300	330	mV	
《Control Parts》						
Γ _H Level Input Voltage	V _H	2.0	-	V _{CC}	V	
Γ _L Level Input Voltage	V _L	0	-	1.0	V	
SDA Γ _L Sink Current	I _{SIN}	4.0	-	-	mA	
DET Detection Level Γ _H	V _{DH}	2.0	-	V _{CC}	V	
DET Detection Level Γ _L	V _{DL}	0	-	1.0	V	
DET Input Bias Current	I _{DET}	0	-2.0	-20	μA	

※1 Measure at separation of 75Ω+75Ω

● Reference Value (Unless otherwise specified, Ta=25°C, V_{CC}=5V)

Parameter	Symbol	Min	Typ	Max	Unit	Conditions
《Video Driver Parts》						
Frequency Characteristic2	V _{F2}	-3	-1	1	dB	V _{IN} =0.7V _{P-P} , f=1M/10MHz
Mute Attenuation	V _{MT}	-	-40	-	dB	V _{IN} =1V _{P-P} , f=30MHz
Channel Crosstalk	C _{TV}	-	-40	-	dB	V _{IN} =1V _{P-P} , f=20MHz

● BH7601FS

Electrical Characteristics (Unless otherwise specified, Ta=25°C, V_{CC}=5V)

Parameter	Symbol	Min	Typ	Max	Unit	Conditions
《All Circuit》						
Circuit Current	I _{CC}	13.5	27.0	40.5	mA	No signal
LINEOUT 「H」 Voltage	V _{LOH}	3.5	4.25	5.0	V	(V _{CC} =5V±5%)
LINEOUT 「M」 Voltage	V _{LOM}	1.4	1.9	2.4	V	(V _{CC} =5V±5%)
LINEOUT 「L」 Voltage	V _{LO}	0.0	0.1	0.5	V	(V _{CC} =5V±5%)
LINEOUT Impedance	Z _{LO}	1.3	1.8	2.3	kΩ	
《Video Driver Parts》						
Voltage Gain	G _V	1.65	2.45	3.25	dB	V _{IN} =0.75V _{P-P} , f=1MHz ※1
Frequency Characteristics	V _{F1}	-1	0	1	dB	V _{IN} =0.75V _{P-P} , f=1M/10MHz
MUTE Input Parts Impedance	Z _{MUTE}	75	100	125	kΩ	
MUTE 「H」 Level Input Voltage	V _{MH}	2.0	-	V _{CC}	V	
MUTE 「L」 Level Input Voltage	V _{ML}	0	-	1.0	V	
PB, PR Input Impedance	Z _{IN}	14	20	26	kΩ	
《Control Parts》						
「H」 Level Input Voltage	V _H	2.0	-	V _{CC}	V	
「L」 Level Input Voltage	V _L	0	-	1.0	V	
SDA 「L」 Sink Current	I _{SIN}	4.0	-	-	mA	
DET Detection Level 「H」	V _{DH}	2.0	-	V _{CC}	V	
DET Detection Level 「L」	V _{DL}	0	-	1.0	V	
DET Input Bias Current	I _{DET}	0	-2.0	-20	μA	

※1 Measure at separation of 75Ω +75Ω

● Reference Value (Unless otherwise specified, Ta=25°C, V_{CC}=5V)

Parameter	Symbol	Min	Typ	Max	Unit	Conditions
《Video Driver Parts》						
Frequency Characteristics2	V _{F2}	-	-1	-	dB	V _{IN} =0.53V _{P-P} , f=1M/30MHz
Mute Attenuation	V _{MT}	-	-40	-	dB	V _{IN} =0.75V _{P-P} , f=20MHz
Channel Crosstalk	C _{TV}	-	-40	-	dB	V _{IN} =0.75V _{P-P} , f=20MHz

● BH7602FS

Electrical Characteristics (Unless otherwise specified, Ta=25°C, V_{CC}=5V)

Parameter	Symbol	Min	Typ	Max	Unit	Conditions
《All Circuits》						
V _{CC} Circuit Current	I _{VCC}	44	56	68	mA	No signal
V _{CC} Circuit Current PD	I _{PD}	-	1.5	3.0	mA	Power down
《Video Driver Parts》						
Y/PB/PR OUT Voltage Gain	G ₂₀	5.5	6.0	6.5	dB	V _{in} =1.0V _{P-P} , f=100kHz
Y/PB/PR OUT Maximum Output Level	V _{OM20}	2.6	2.9	-	V _{P-P}	V _{in} : THD=1.0% f=10kHz
Y OUT LPF1 Frequency Characteristics 1	F ₁₂₀₁	-5.0	-1.5	1.0	dB	V _{in} =1.0V _{P-P} , f=30M/100kHz, LPF1:ON
Y OUT LPF2 Frequency Characteristics 1	F ₂₂₀₁	-1.5	-0.5	0.5	dB	V _{in} =1.0V _{P-P} , f=13.5M/100kHz, LPF2:ON
PB/PR OUT LPF1 Frequency Characteristics 1	F ₁₁₇₁	-5.0	-1.5	1.0	dB	V _{in} =1.0V _{P-P} , f=15M/100kHz, LPF1:ON
PB/PR OUT LPF2 Frequency Characteristics 1	F ₂₁₇₁	-1.5	-0.5	0.5	dB	V _{in} =1.0V _{P-P} , f=6.75M/100kHz, LPF2:ON
Y OUT LPF1 Frequency Characteristics 2	F ₁₂₀₂	-	-45	-28	dB	V _{in} =1.0V _{P-P} , f=74.25M/100kHz, LPF1:ON
Y OUT LPF2 Frequency Characteristics 2	F ₂₂₀₂	-	-40	-28	dB	V _{in} =1.0V _{P-P} , f=54M/100kHz, LPF2:ON
PB/PR OUT LPF1 Frequency Characteristics 2	F ₁₁₇₂	-	-45	-28	dB	V _{in} =1.0V _{P-P} , f=37.125M/100kHz, LPF1:ON
PB/PR OUT LPF2 Frequency Characteristics 2	F ₂₁₇₂	-	-40	-28	dB	V _{in} =1.0V _{P-P} , f=27M/100kHz, LPF2:ON
MUTE Attenuation	M _{T20}	-	-65	-55	dB	V _{in} =1.0V _{P-P} , f=4.43MHz
Channel Crosstalk	M _{TCH}	-	-65	-55	dB	V _{in} =1.0V _{P-P} , f=4.43MHz
《D_DET》						
Input Voltage H	V _{I14H}	4.0	-	V _{CC}	V	
Input Voltage M	V _{I14L}	0.0	-	1.0	V	
Input Impedance	Z _{I14}	100	150	200	kΩ	Pull Up Resistance
《LINE_OUT》						
Output Voltage H	V _{O13H}	4.2	4.5	4.8	V	
Output Voltage M	V _{O13M}	1.7	2.0	2.3	V	
Output Voltage L	V _{O13L}	0.0	0.1	0.5	V	
Input Impedance	Z _{O13}	0.5	0.9	1.3	kΩ	Pull Down Resistance

● Electrical Characteristics (Unless otherwise specified, Ta=25°C, V_{CC}=5V)

Parameter	Symbol	Min	Typ	Max	Unit	Conditions
《ADR》						
Input Voltage H	V _{I8H}	2.0	-	V _{CC}	V	
Input Voltage L	V _{I8L}	0.0	-	1.0	V	
Input Impedance	Z _{I8}	65	100	135	kΩ	Pull Down Resistance
《SCL, SDA》						
Input Voltage H	V _{I9H}	2.0	-	V _{CC}	V	
Input Voltage L	V _{I9L}	0.0	-	1.0	V	
Input Bias Current	I _{B9}	-10	0	10	μA	

※2 VIDEO part input signal : 0.5~1.5V (1.0Vp-p) sine wave, V_{REF} pin: 0.9V

● Block Diagram

BH7600AFS

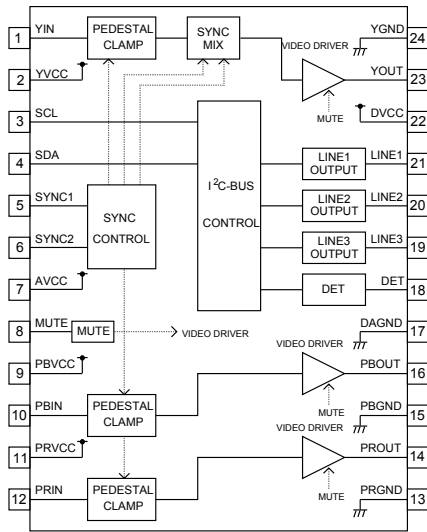

Fig.1

BH7601FS

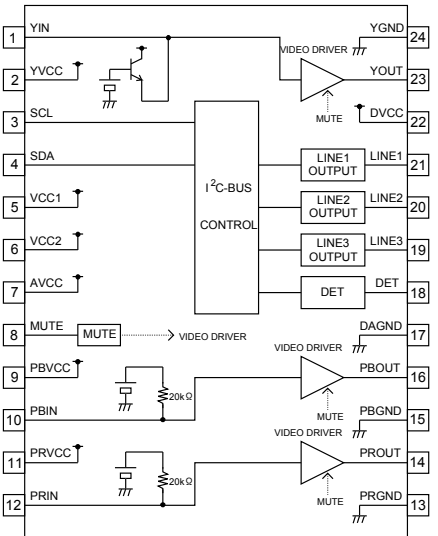

Fig.2

BH7602FS

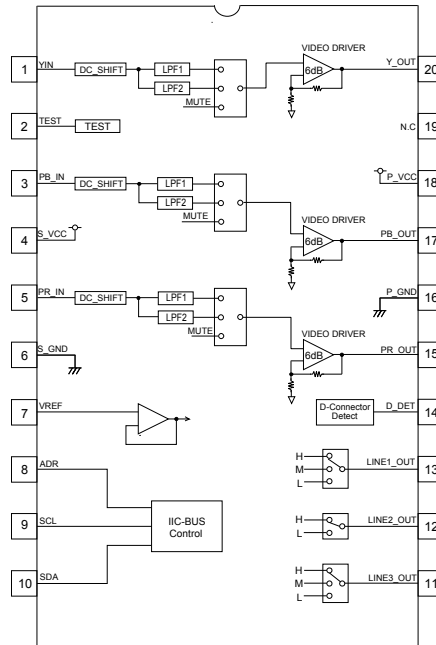

Fig.3

● Terminal Description · Input/Output Equivalent Circuit

BH7600AFS

Pin.No	Pin Name	IN	OUT	Standard voltage	Input/Output Equivalent Circuit	Terminal Description
1	YIN	○	—	2.3V		<p>Y Signal Input Terminal</p> <p>This terminal is Y signal input terminal. The input is pedestal clamp. It is possible to mix sync signal by pulse of SYNC1, SYNC2.</p>
2 7 9 11 22	YVcc AVcc PBVcc PRVcc DVcc	—	—	5.0V		<p>Vcc Terminal</p> <p>YVcc, PBVcc, PRVcc are Vcc terminal of video driver. AVcc is the Vcc terminal of the other analog parts. DVcc is the Vcc terminal of the digital parts.</p>
5 6	SYNC1 SYNC2	○	—	—		<p>Sync Control Terminal</p> <p>It is sync control pulse input terminal synchronized to Y signal for pedestal clamp.</p>
13 15 17 24	PRGND PBGND DAGND YGND	—	—	0.0V		<p>GND Terminal</p> <p>PRGND, PBGND, YGND are GND terminal of video driver. DAGND is the GND terminal except driver parts.</p>
10 12	PBIN PRIN	○	—	2.8V		<p>PB, PR Signal Input Terminal</p> <p>This terminal is the input terminal. This input is pedestal clamp.</p>
19 20 21	LINE3 LINE2 LINE1	—	○	—		<p>Line Output Terminal</p> <p>It is the line 3 value output terminal for D terminal. This terminal is controlled by I²C BUS.</p>

※ The values in the terminal descriptions and input/output equivalent circuit are for reference only - they are not guaranteed.

● Terminal Description · Input/Output Equivalent Circuit
BH7600AFS/BH7601FS

Pin.No	Pin Name	IN	OUT	Standard Voltage	Input/Output Equivalent Circuit	Terminal Description
3	SCL	○	—	—		<p>I²C BUS CLOCK Input Terminal</p> <p>This terminal is serial clock input terminal that is based on I²C BUS. Usually, it use to pull up by resistor.</p>
4	SDA	○	—	—		<p>I²C BUS DATA Input Terminal</p> <p>This terminal is serial data input terminal that is based on I²C BUS. Usually, it use to pull up by resistor.</p>
8	MUTE	○	—	5.0V		<p>Mute Control Terminal</p> <p>This terminal is connected to Vcc with 100kΩ, when the terminal is open or High, mute mode, when Low, normal mode.</p>
14 16	PROUT PBOUT	—	○	2.1V		<p>PB, PR Signal Output Terminal</p> <p>This terminal is the PR, PB output terminal.</p>
23	YOUT	—	○	1.2V (BH7600AFS) 0.7V (BH7601FS)		<p>Y Signal Output Terminal</p> <p>This terminal is the Y signal output terminal.</p>
18	DET	○	—	—		<p>DET Terminal</p> <p>This terminal is the detector to connect D terminal. Usually, it use to pull up by resistor.</p>

※ The values in the terminal descriptions and input/output equivalent circuit are for reference only - they are not guaranteed.

● Terminal Description · Input/Output Equivalent Circuit

BH7601FS

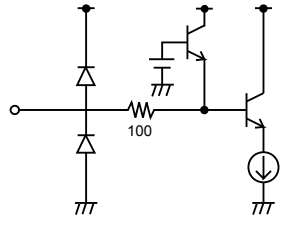
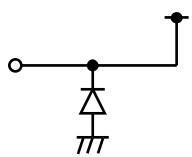
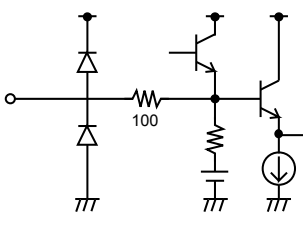
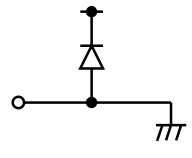
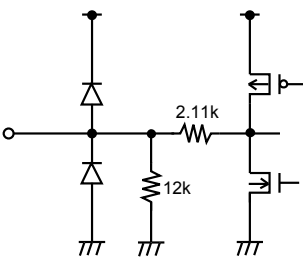
Pin.No	Pin Name	IN	OUT	Standard Voltage	Input/Output Equivalent Circuit	Terminal Description
1	YIN	○	—	2.8V		Y Signal Input Terminal This terminal is Y signal input terminal. The input is sync tip clamp.
2 5 6 7 9 11 22	YVcc Vcc1 Vcc2 AVcc PBVcc PRVcc DVcc	—	—	5.0V		Vcc Terminal YVcc, PBVcc, PRVcc are Vcc terminal of video driver. Vcc1, Vcc2, AVcc are the Vcc terminal of the other analog parts (These 3 terminals are connected inside), DVcc is Vcc terminal of the digital parts.
10 12	PBIN PRIN	○	—	2.1V		PB, PR Signal Input Terminal This terminal is the PR, PB input terminal. The input is bias type.
13 15 17 24	PRGND PBGND DAGND YGND	—	—	0.0V		GND Terminal PRGND, PBGND, YGND are GND terminal of video driver. DAGND is the GND terminal of the blocks except video driver.
19 20 21	LINE3 LINE2 LINE1	—	○	—		Line Output Terminal This terminal is the line 3 value output terminal for D terminal. This terminal is controlled by I ² C BUS.

※ The values in the terminal descriptions and input/output equivalent circuit are for reference only - they are not guaranteed.

● Terminal Description · Input/Output Equivalent Circuit

BH7602FS

Pin.No	Pin Name	IN	OUT	Standard Voltage	Input/Output Equivalent Circuit	Terminal Description
1 3 5	Y_IN PB_IN PR_IN	○	—	$(V_{S7}-0.4)$ ~ $(V_{S7}+0.9)$		Component signal input terminal Input range is possible to regulate by VREF terminal input voltage (V_{S7}). When Vcc off, this terminal become high impedance.
20 17 15	Y_OUT PB_OUT PR_OUT	—	○	0.7 At input terminal voltage $= (V_{S7}-0.4)$		Component signal output terminal It is possible to output two drivers.
7	VREF	○	—	0.4~1.4		Reference Terminal This terminal is input terminal of inside reference voltage for DC-shift circuit.
14	D_DET	○	—	5.0V		D Terminal Input Terminal for detector to connect Terminal condition (H/L) is possible to read out by I ² C BUS. When D mode, it is possible to control of power-down into terminal condition (H/L).
13 12 11	LINE1_OUT LINE2_OUT LINE3_OUT	—	○	4.5(H) 2.0(M) 0.1(L)		LINE-OUT Terminal This terminal is the line 3 value output terminal for controlled by I ² C BUS. Each distinction output are correspond with the D terminal standard.
9	SCL	○	—	—		I ² C BUS clock Input Terminal This terminal is possible to operate max 400kHz. When Vcc off, this terminal become high impedance.

※ The values in the terminal descriptions and input/output equivalent circuit are for reference only - they are not guaranteed.

● Terminal Description · Input/Output Equivalent Circuit

BH7602FS

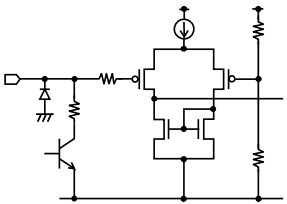
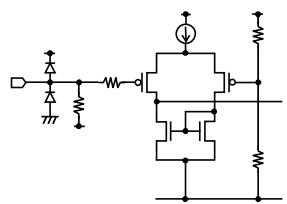
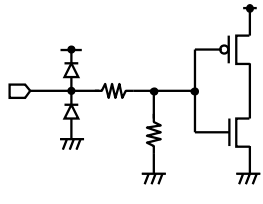
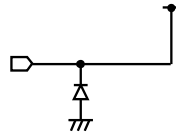
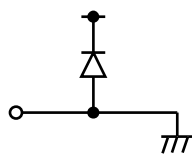
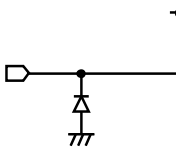
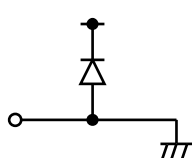
Pin.No	Pin Name	IN	OUT	Standard Voltage	Input/Output Equivalent Circuit	Terminal Description
10	SDA	○	○	—		<p>I²C-BUS Data Input/ Output Terminal</p> <p>This terminal is possible to operate max 400kHz. When VCC off, this terminal become high impedance.</p>
8	ADR	○	—	0V		<p>Slave Address Change Terminal</p> <p>LOW: D8H High: DAH</p>
2	TEST	○	—	0V		<p>LOGIC Test Mode Change Terminal</p> <p>Usually not use. This terminal is 0V input (=GND).</p>
18	P_VCC	—	—	5.0V		<p>VCC terminal for driver output.</p>
19	P_GND	—	—	0V		<p>GND terminal for driver output.</p>
4	S_VCC	—	—	5.0V		<p>VCC terminal for the analog part except driver and digital part.</p>
6	S_GND	—	—	0V		<p>GND terminal for the analog part except driver and digital part.</p>

※ The values in the terminal descriptions and input/output equivalent circuit are for reference only - they are not guaranteed.

■ I²C BUS Control Input Specifications < BH7600AFS / BH7601FS >

- I²C BUS Format (WRITE MODE)

S	SLAVE ADDRESS	A	DATA	A	P
---	---------------	---	------	---	---

S: Start Condition A: Acknowledge P: Stop Condition

	b7	b6	b5	b4	b3	b2	b1	b0
Slave address	1	1	0	1	1	0	0	0
DATA	0	0	LINE1		LINE2		LINE3	

- Select Input Switch · Setting Mode (When power on, it becomes * condition.)

	Explanation		Explanation
LINE1	Setting output of LINE1 OUT 00: LOW *(BH7601FS) 01: LOW 10: MIDDLE 11: HIGH *(BH7600AFS)	LINE3	Setting output of LINE3 OUT 00: LOW *(BH7601FS) 01: LOW 10: MIDDLE 11: HIGH *(BH7600AFS)
LINE2	Setting output of LINE2 00: LOW *(BH7601FS) 01: LOW 10: MIDDLE 11: HIGH *(BH7600AFS)		

- I²C BUS Format (READ MODE)

S	SLAVE ADDRESS	A	DATA	NA	P
---	---------------	---	------	----	---

S: Start Condition A: Acknowledge NA: No Acknowledge P: Stop Condition

	b7	b6	b5	b4	b3	b2	b1	b0
Slave address	1	1	0	1	1	0	0	1
DATA	0	0	0	0	0	0	0	DET

- Select Input Switch · Setting Mode

	Explanation
DET	Read out the condition of DET (18PIN) pin. 0: LOW 1: HIGH

■ I²C BUS Control Input Specifications (BH7602FS)

- I²C BUS Format (WRITE MODE)



S: Start Condition A: Acknowledge P: Stop Condition

	b7	b6	b5	b4	b3	b2	b1	b0
Slave address	1	1	0	1	1	0	ADR	R/W
DATA1	LPF_SW		LINE1		LINE2	0	LINE3	
DATA2	PD	D_MODE	0	0	0	0	0	0

- Select Input Switch · Setting Mode (When power on, it becomes * condition.)

	Explanation		Explanation
ADR	Slave Address (write mode) set by ADR pin. 0: "D8H" when ADR is Low. 1: "DAH" when ADR is High.	R/W	READ/WRITE Setting Mode 0: WRITE 1: READ
LPF_SW	LPF_SW Setting output 00: LPF1 01: LPF2 10: — 11: MUTE * (NOTE) "10" is No use	LINE1	Setting output of LINE1_OUT for D terminal 00: L * 01: L 10: M 11: H
LINE2	Setting output of LINE2_OUT for D terminal 0: L * 1: H	LINE3	Setting of output of LINE3_OUT for D terminal 00: L * 01: L 10: M 11: H
PD	Power down control 0: Normal * 1: PD (Power down)	D_MODE	D terminal detect mode change 0: OFF * 1: ON (D terminal detect mode)

- D_MODE (D terminal detect mode)
When I²C BUS sets D_MODE=ON, POWER DOWN is controlled by D_DET pin input level and the PD pin input is ignore.

D_MODE	PD	D_DET	Output
OFF	0	L	Normal
	0	H	Normal
	1	L	Power down
	1	H	Power down
ON	0	L	Normal
	0	H	Power down
	1	L	Normal
	1	H	Power down

● I²C BUS Format (READ MODE)

S	SLAVE ADDRESS	A	DATA1	NA	P
---	---------------	---	-------	----	---

S: Start Condition A: Acknowledge NA: No Acknowledge P: Stop Condition

	b7	b6	b5	b4	b3	b2	b1	b0
Slave address	1	1	0	1	1	0	ADR	R/W
DATA	0	0	0	0	0	0	0	D_DET

● Select Input Switch - Setting Mode

	Explanation		Explanation
ADR	Slave Address (read mode) set by ADR 0: "D9H", when ADR is LOW. 1: "DBH", when ADR is High.	D_DET	Read out D_DET condition 0: LOW 1: HI
R/W	READ/WRITE setting mode 0: WRITE 1: READ		

■ BH7600AFS Sync-mix operation

On BH7600AFS, it is necessary to operate sync-mix Y signal and control signal synchronized with the Y signal (SYNC1, SYNC2).

Use this control signal, (1) When the Y signal which has no sync is inputted, it is outputted with a sync. (2) When the Y signal which has sync is inputted, it is possible to output as that. Then, please refer to show how to use SYNC1, SYNC2 pulse.

(1) When the Y signal which has no sync is inputted

(i) 3 value sync mix

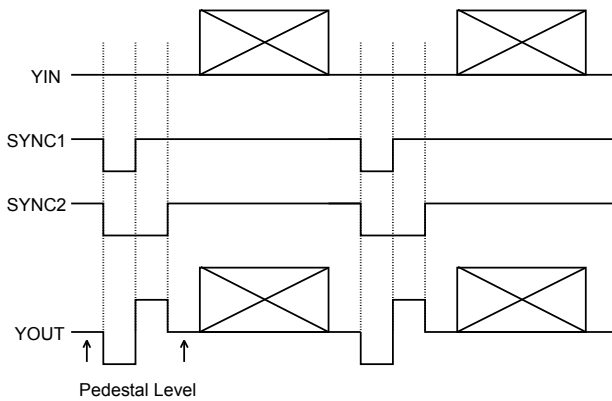

(ii) 2 value sync mix

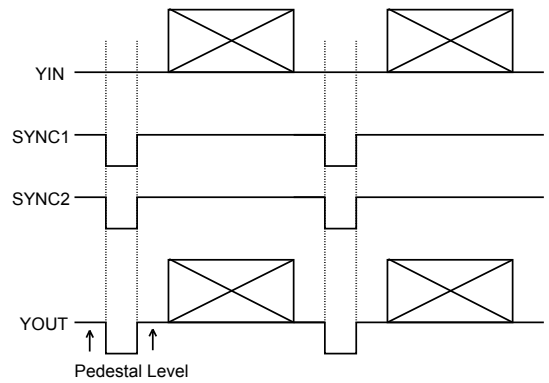

(2) When the Y signal which has a sync is inputted

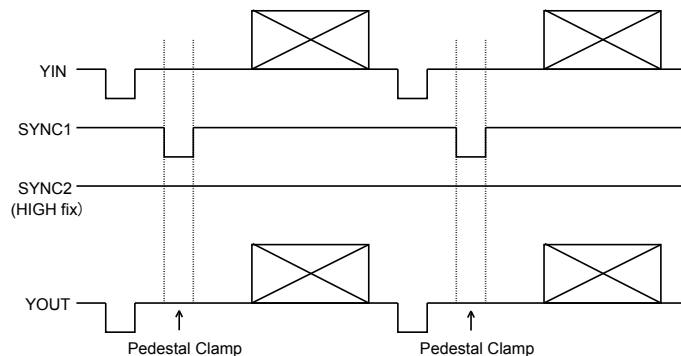

● Operation description of each block

■ BH7602FS How to set video input level in DC_SHFT circuit

BH7602FS is build in DC_Shift block and it operate without input coupling capacitor. It is necessary to set input voltage of VREF (7pin) terminal to VIDEO signal input level because of enough output dynamic range.

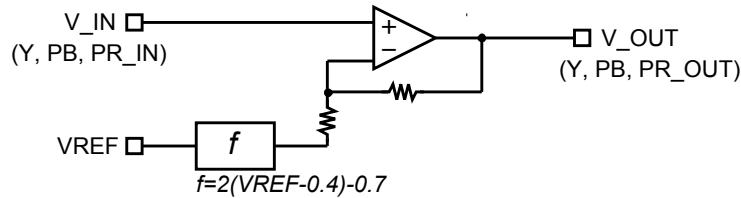

Fig. 4 DC_Shift block equivalent circuit

The relation of V_IN, VREF, V_OUT in this place

$$V_OUT = 0.7 + 2(V_IN - VREF + 0.4) \tag{eq.1}$$

and the input possible range of VREF is

$$0.4 \leq VREF \leq 1.4 \text{ [V]} \tag{eq.2}$$

It shows the relation of V_IN-V_OUT at each VREF value on Fig.6.

On the other hand, the operation range of V_OUT (VIDEO OUTPUT) becomes 0.7V~3.3V (2.6Vp-p) of the circuit composition, and needs to adjust VREF terminal voltage to be kept this range for inputted VIDEO signal. VREF terminal voltage and V_IN input possible range are shown in Fig.5. Caution on use, after confirming Fig.5, adjust VREF terminal voltage.

Fig. 5 The relation of VREF terminal voltage and input possible range

VREF [V]	V_IN input possible range [V]
0.4	0.0~1.3
0.5	0.1~1.4
0.6	0.2~1.5
0.7	0.3~1.6
0.8	0.4~1.7
0.9	0.5~1.8
1.0	0.6~1.9
1.1	0.7~2.0
1.2	0.8~2.1
1.3	0.9~2.2
1.4	1.0~2.3

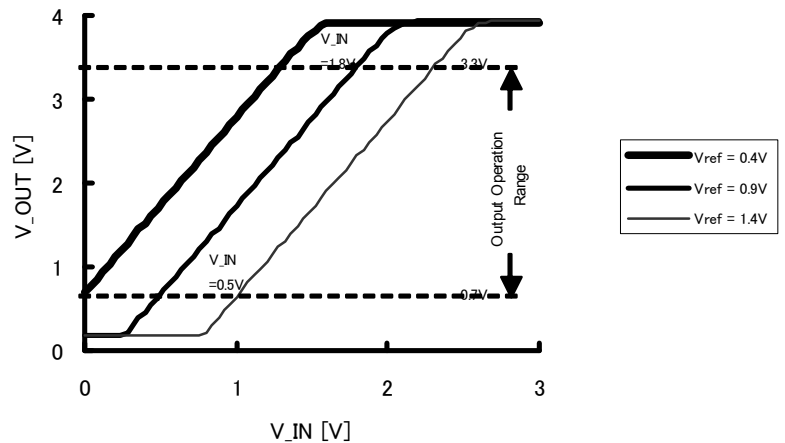
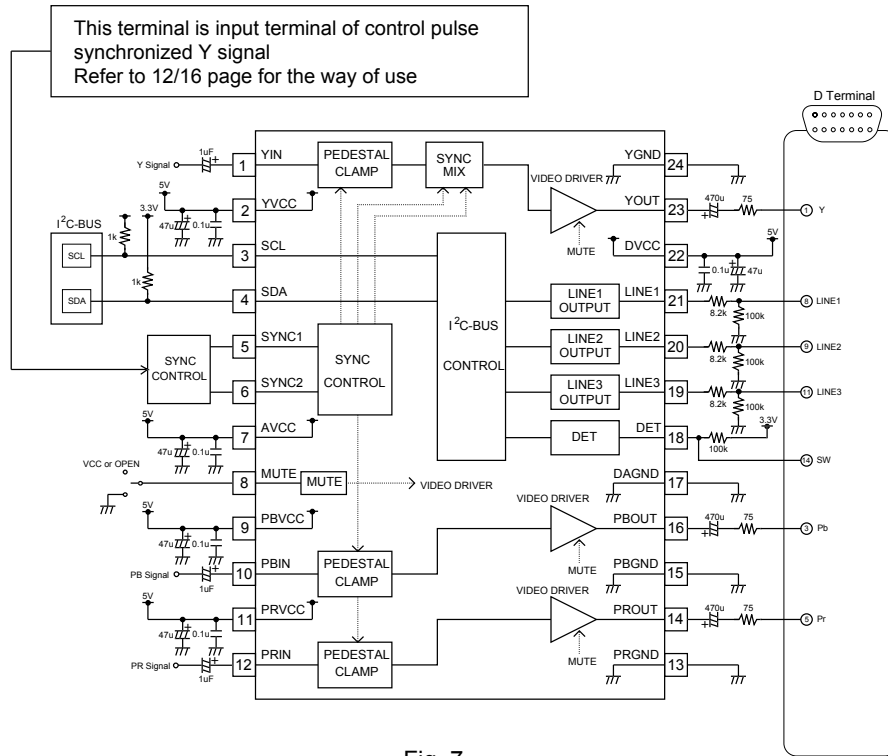

Fig. 6 The relation of V_IN-V_OUT at each VREF value (measurement value)

● Application circuit

● BH7600AFS



● BH7602FS

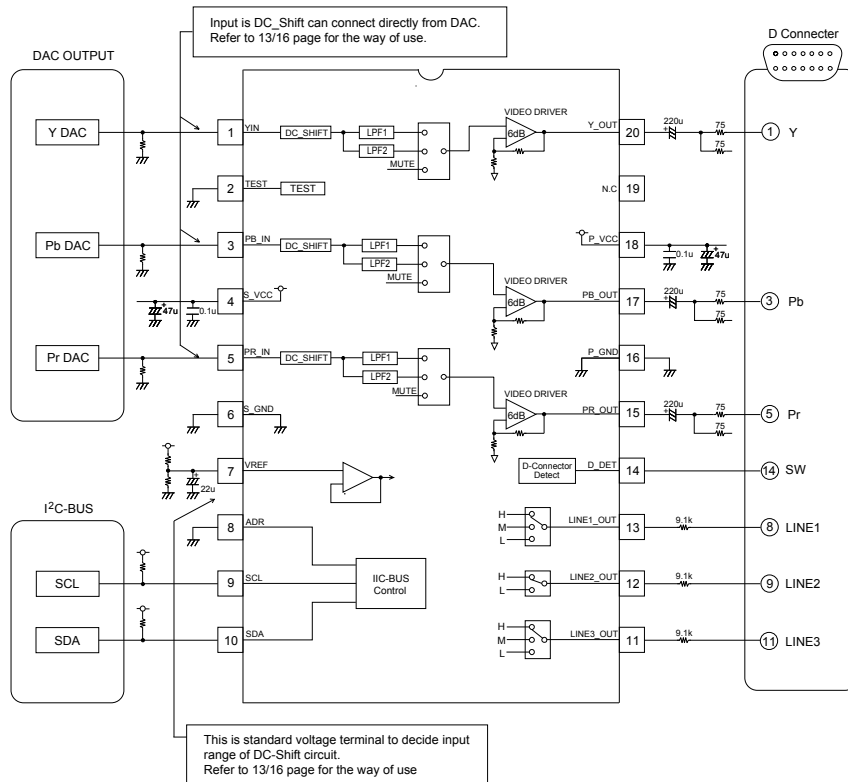

● Reference Data

BH7600AFS

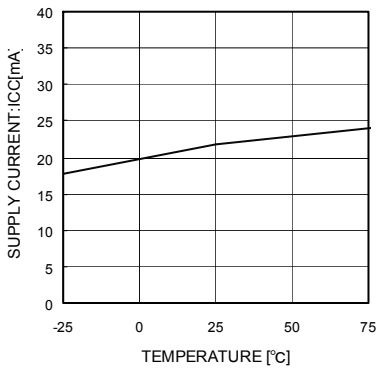

Fig.9 Circuit Current

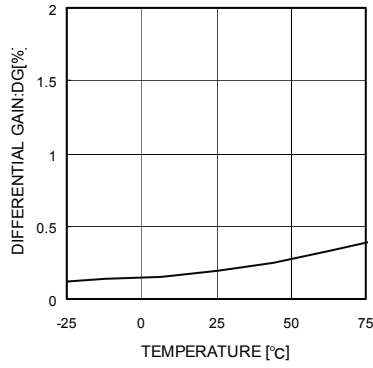

Fig.10 Differential Gain

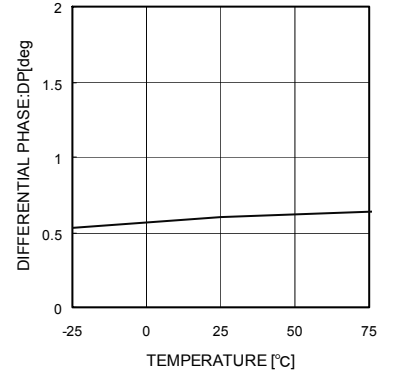

Fig.11 Differential Phase

BH7601FS

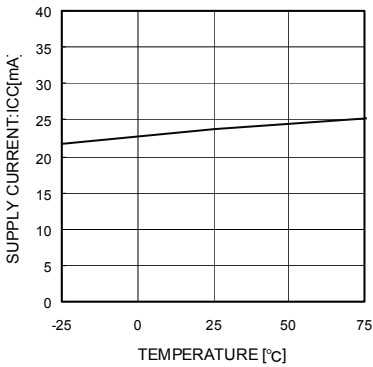

Fig.12 Circuit Current

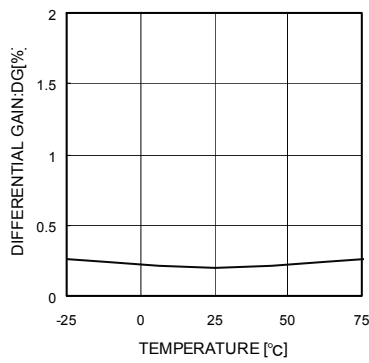

Fig.13 Differential Gain

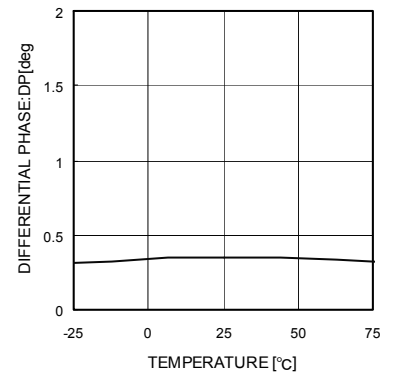

Fig.14 Differential Phase

BH7602FS

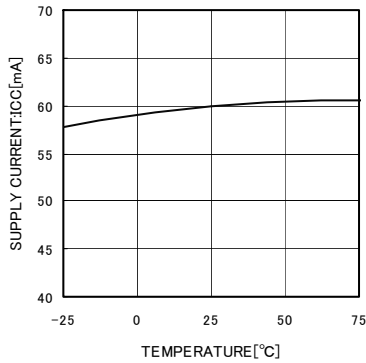

Fig.15 Circuit Current

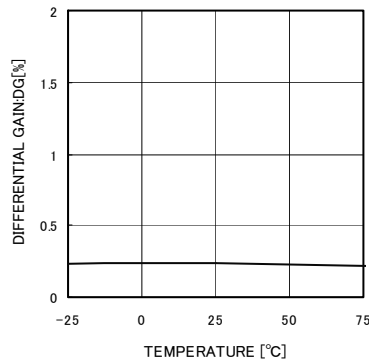

Fig.16 Differential Gain

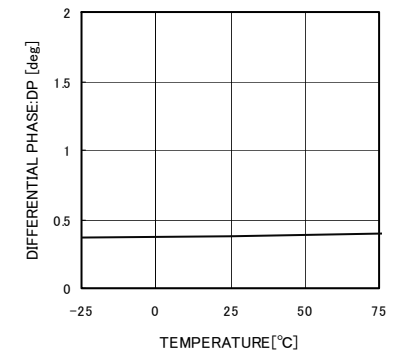

Fig.17 Differential Phase

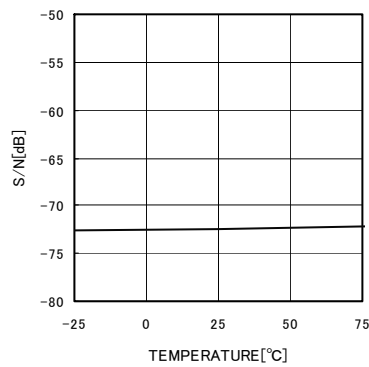

Fig.18 S/N

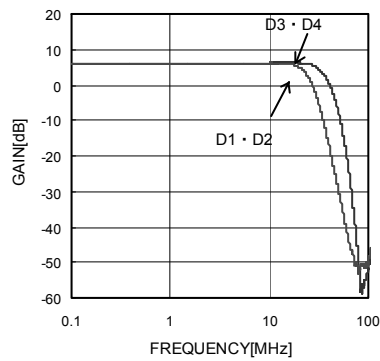

Fig.19 YLPF Characteristics

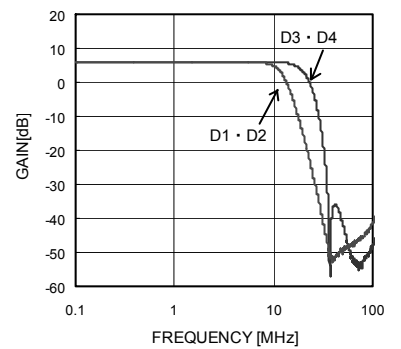
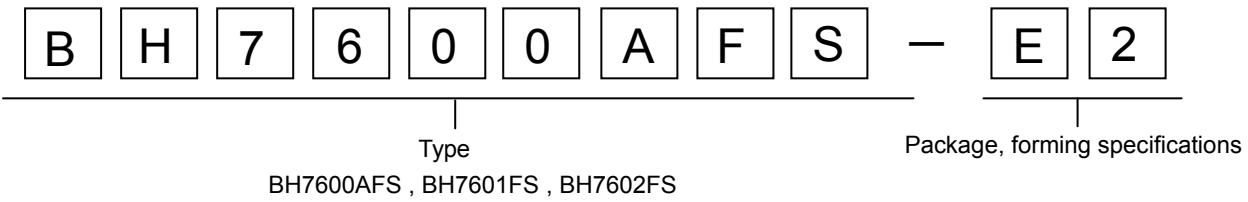
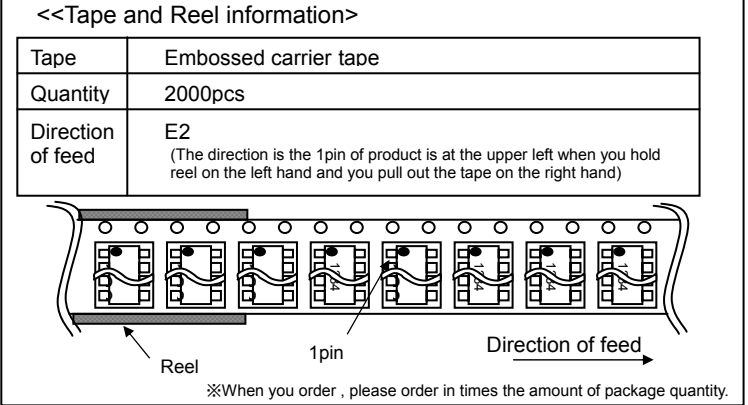
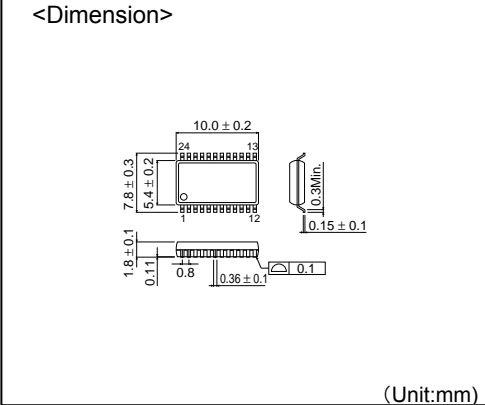

Fig.20 PBLPF Characteristics

● Selection of order type



SSOP-A24



SSOP-A20

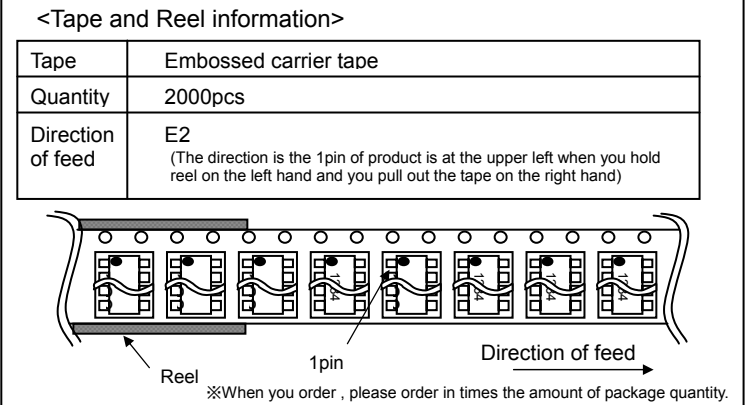
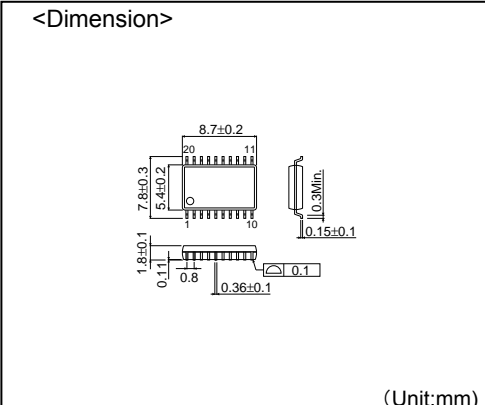

Notes

No copying or reproduction of this document, in part or in whole, is permitted without the consent of ROHM Co.,Ltd.

The content specified herein is subject to change for improvement without notice.

The content specified herein is for the purpose of introducing ROHM's products (hereinafter "Products"). If you wish to use any such Product, please be sure to refer to the specifications, which can be obtained from ROHM upon request.

Examples of application circuits, circuit constants and any other information contained herein illustrate the standard usage and operations of the Products. The peripheral conditions must be taken into account when designing circuits for mass production.

Great care was taken in ensuring the accuracy of the information specified in this document. However, should you incur any damage arising from any inaccuracy or misprint of such information, ROHM shall bear no responsibility for such damage.

The technical information specified herein is intended only to show the typical functions of and examples of application circuits for the Products. ROHM does not grant you, explicitly or implicitly, any license to use or exercise intellectual property or other rights held by ROHM and other parties. ROHM shall bear no responsibility whatsoever for any dispute arising from the use of such technical information.

The Products specified in this document are intended to be used with general-use electronic equipment or devices (such as audio visual equipment, office-automation equipment, communication devices, electronic appliances and amusement devices).

The Products specified in this document are not designed to be radiation tolerant.

While ROHM always makes efforts to enhance the quality and reliability of its Products, a Product may fail or malfunction for a variety of reasons.

Please be sure to implement in your equipment using the Products safety measures to guard against the possibility of physical injury, fire or any other damage caused in the event of the failure of any Product, such as derating, redundancy, fire control and fail-safe designs. ROHM shall bear no responsibility whatsoever for your use of any Product outside of the prescribed scope or not in accordance with the instruction manual.

The Products are not designed or manufactured to be used with any equipment, device or system which requires an extremely high level of reliability the failure or malfunction of which may result in a direct threat to human life or create a risk of human injury (such as a medical instrument, transportation equipment, aerospace machinery, nuclear-reactor controller, fuel-controller or other safety device). ROHM shall bear no responsibility in any way for use of any of the Products for the above special purposes. If a Product is intended to be used for any such special purpose, please contact a ROHM sales representative before purchasing.

If you intend to export or ship overseas any Product or technology specified herein that may be controlled under the Foreign Exchange and the Foreign Trade Law, you will be required to obtain a license or permit under the Law.



Thank you for your accessing to ROHM product informations.
More detail product informations and catalogs are available, please contact us.

ROHM Customer Support System

<http://www.rohm.com/contact/>