

1. PART NO. EXPRESSION :

P D B 1 5 1 1 1 0 1 M Z F
 (a) (b) (c) (d)(e)(f)

- (a) Series code
- (b) Dimension code
- (c) Inductance code : 101 = 100uH
- (d) Tolerance code : M = ±20%
- (e) X, Y, Z : Standard part
- (f) F : Lead Free

2. CONFIGURATION & DIMENSIONS :

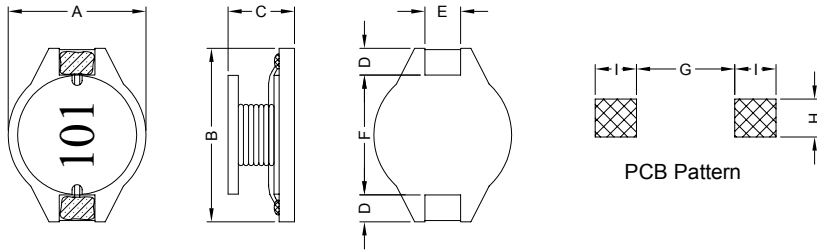

Unit:m/m

A	B	C	D	E	F	G	H	I
15.0±0.3	18.4±0.3	11.5 Max.	2.4±0.2	2.2±0.2	13.3±0.3	12.7 Ref.	2.8 Ref.	3.0 Ref.

3. SCHEMATIC :

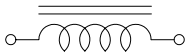

4. MATERIALS :

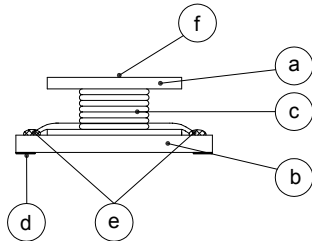

- (a) Core : DR Ferrite Core
- (b) Base : LCP
- (c) Wire : Enamelled Copper Wire
- (d) Terminal : Tinned Copper Plate
- (e) Adhesive : Epoxy
- (f) Ink : Bon Margue

5. GENERAL SPECIFICATION :

- a) Temp. rise : 40°C Typ. at Irms
- b) ΔL/L0A = 10% Typ. at Isat
- c) Storage temp. : -40°C to +125°C
- d) Operating temp. : -40°C to +80°C
- e) Resistance to solder heat : 260°C.10 secs



RoHS Compliant

NOTE : Specifications subject to change without notice. Please check our website for latest information.

01.05.2008



SUPERWORLD ELECTRONICS (S) PTE LTD

6. ELECTRICAL CHARACTERISTICS :

Part No.	Inductance (μ H)	Test Frequency (Hz)	RDC ($m\Omega$) Max.	Isat (A)	Irms (A)
PDB1511470MZF	47.00 \pm 20%	1V/100K	55.0	5.20	3.70
PDB1511680MZF	68.00 \pm 20%	1V/100K	75.0	4.30	3.10
PDB1511101MZF	100.00 \pm 20%	1V/100K	125.0	3.60	2.50
PDB1511151MZF	150.00 \pm 20%	1V/100K	190.0	3.00	2.00
PDB1511221MZF	220.00 \pm 20%	1V/100K	280.0	2.50	1.60
PDB1511331MZF	330.00 \pm 20%	1V/100K	370.0	2.00	1.40
PDB1511471MZF	470.00 \pm 20%	1V/100K	510.0	1.60	1.20
PDB1511681MZF	680.00 \pm 20%	1V/100K	800.0	1.40	1.00
PDB1511102MZF	1000.00 \pm 20%	1V/100K	1100.0	1.15	0.80
PDB1511152MZF	1500.00 \pm 20%	1V/100K	1600.0	0.95	0.60
PDB1511222MZF	2200.00 \pm 20%	1V/100K	2300.0	0.80	0.50
PDB1511332MZF	3300.00 \pm 20%	1V/100K	3600.0	0.65	0.40
PDB1511472MZF	4700.00 \pm 20%	1V/100K	5200.0	0.55	0.35
PDB1511682MZF	6800.00 \pm 20%	1V/100K	7700.0	0.45	0.30
PDB1511103MZF	10000.00 \pm 20%	1V/100K	11000.0	0.38	0.25



RoHS Compliant

NOTE : Specifications subject to change without notice. Please check our website for latest information.

01.05.2008



SUPERWORLD ELECTRONICS (S) PTE LTD

7. CHARACTERISTICS CURVES :

@ TEMP. RISE VS. DC SUPERPOSITION RESPONSE CURVE

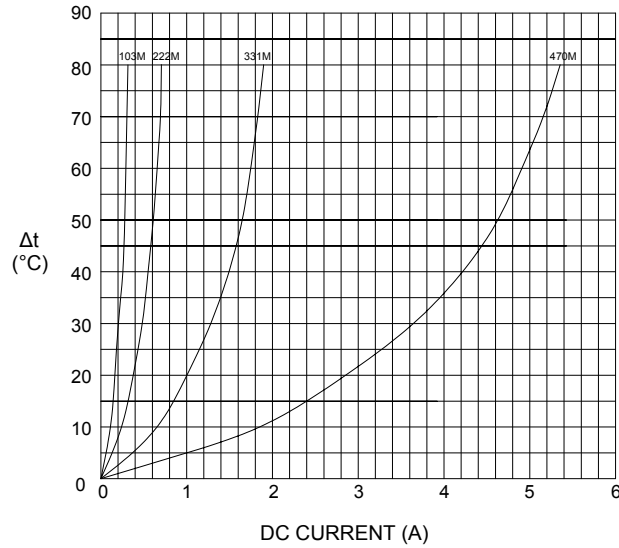

@ INDUCTANCE VS. FREQUENCY RESPONSE CURVE

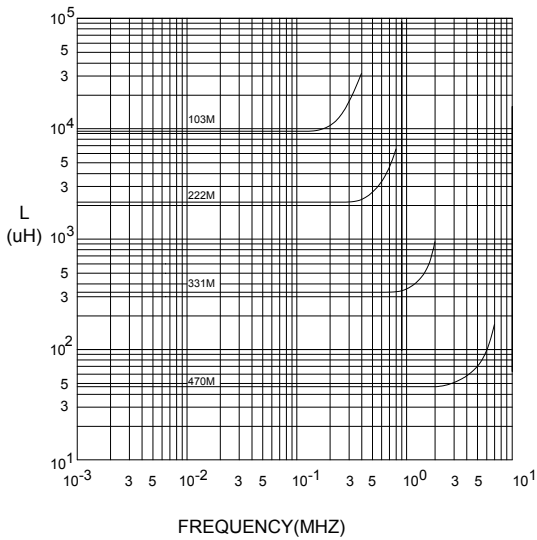

@ INDUCTANCE VS. DC SUPERPOSITION RESPONSE CURVE

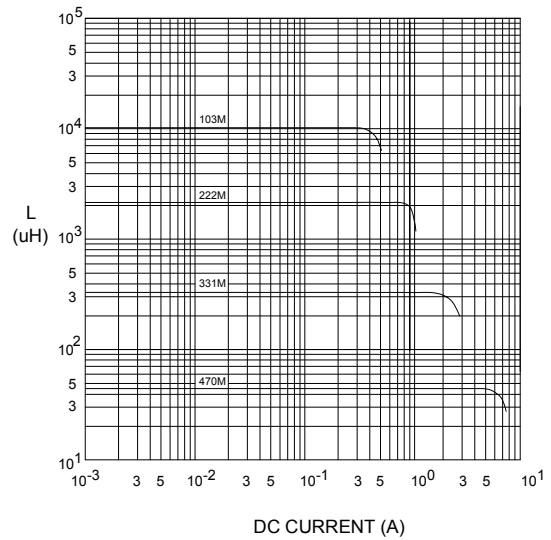

RoHS Compliant

NOTE : Specifications subject to change without notice. Please check our website for latest information.

01.05.2008



SUPERWORLD ELECTRONICS (S) PTE LTD

RECOMMENDED SOLDERING CONDITIONS REFLOW SOLDERINGS

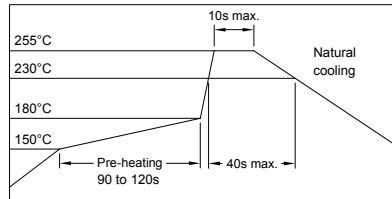

8. PACKAGING INFORMATION :

(1) CONFIGURATION

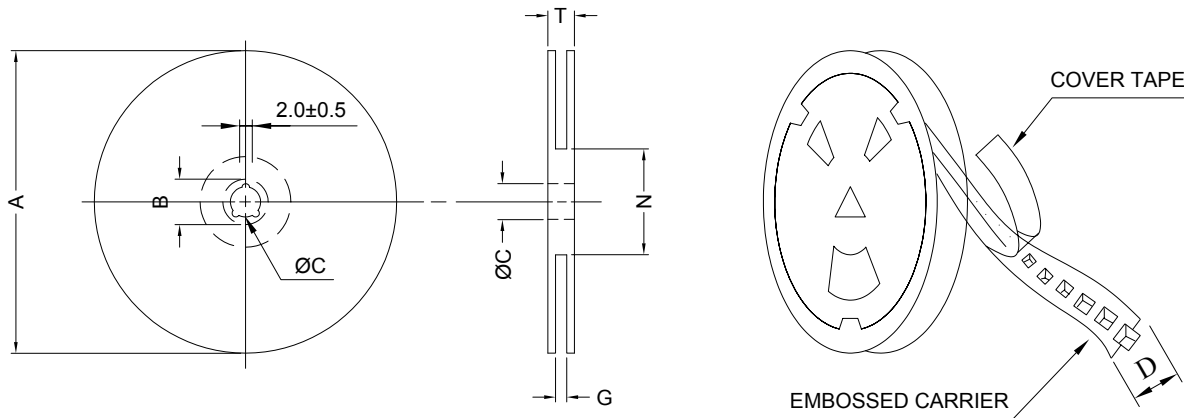

* CARRIER TAPE WIDTH : D

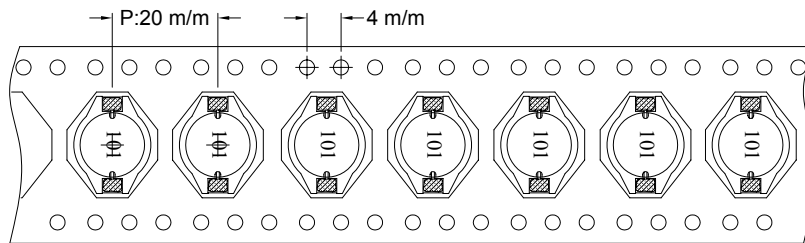

(2) DIMENSIONS

Unit:m/m

STYLE	A	B	C	D	G	N	T
13-32	330	21±0.8	13±0.5	32	34 ⁺⁰	100 ⁻⁰	38.4

(3) Q'TY & G.W. PER PACKAGE

SERIES	INNER : REEL			OUTER : CARTON		
	Q'TY (PCS)	G.W. (gw)	STYLE	Q'TY (PCS)	G.W. (Kg)	SIZE (cm)
PDB1511	200	1370	13-32	800	9.0	40 x 20 x 26



RoHS Compliant

NOTE : Specifications subject to change without notice. Please check our website for latest information.

01.05.2008



SUPERWORLD ELECTRONICS (S) PTE LTD

9. RELIABILITY AND TEST CONDITION :

TEST ITEM	SPECIFICATION	TEST CONDITION
SOLDERABILITY	MORE THAN 90% OF THE TERMINAL ELECTRODE SHALL BE COVERED WITH FRESH SOLDER.	PREHEAT : 125±25°C FOR 60 SECONDS SOLDER : 99%Sn/0.3%Ag/0.7%Cu OR EQUIVALENT SOLDER TEMP. : 245±5°C FLUX : ROSIN DIP TIME : 4±1 SECONDS
THERMAL SHOCK TEST (TEMP. CYCLE)	INDUCTANCE SHALL NOT CHANGE MORE THAN ±20%	ROOM TEMP. → -25±2°C 15 MINUTES → 30 MINUTES ROOM TEMP. → 85±2°C 15 MINUTES → 30 MINUTES TOTAL : 50 CYCLES
HUMIDITY RESISTANCE TEST		TEMPERATURE : 40±2°C HUMIDITY : 90 ~ 95% APPLIED CURRENT : PER SPEC. TIME : 500 HOURS
HIGH TEMP. RESISTANCE TEST		TEMPERATURE : 85±2°C APPLIED CURRENT : PER SPEC. TIME : 500 HOURS



RoHS Compliant

NOTE : Specifications subject to change without notice. Please check our website for latest information.

01.05.2008



SUPERWORLD ELECTRONICS (S) PTE LTD

PG. 5

10. UL CARD :

OBMW2 **November 30, 2000**
Magnet Wire - Component
PACIFIC ELECTRIC WIRE & CABLE (SHENZHEN) CO LTD **E201757**
607 BAOLONG INDUSTRIAL ESTATE LONGGANG, SHENZHEN
GUANGDONG CHINA

Mtl Dsg	Coating Type	TC	ANSI Type	TI
UEW/U	BC	—	—	130
PEW/U	Polyurethane	—	—	155°C
PEWH/U	Polyester	—	MW5-C	180
PEW-NY/U	Modified Polyester	—	MW30-C	155
HAI/U	Polyester	Polyamide	MW24-C	200
UEW-NY/U	Polyester(Amide)(Imide)	Polyamideimide	MW35,73	155
	Polyurethane	Polyamide	MW80-C	130
			MW28-C	130

Marking: Company name and material designation or marked designation on package or reel, and Recognized Component Mark.

See General Information Preceding These Recognitions

1/3/2001 **Underwriters Laboratories Inc.** **Card 1 of 2**

SUMITOMO CHEMICAL CO LTD **E54705 (M)**
5-33 KITAHAMA 4-CHOME CHUO-KO, OSAKA JAPAN

Mtl Dsg	Col	Min Thk mm	UL94 Flame Class	Elec	RTI		w/o Imp	H W I	H A I	H V R	D 4 9 5	C T I
					with Imp	Mech						
Liquid crystal polyester (LCP), designated "EKONOL" or "SUMIKASUPER", furnished in the form of pellets, (Contd)												
E4008, E400X	NC, BK	0.30	94V-0	130	130	130	—	—	—	—	—	—
		0.75	94V-0	130	130	130	3	4	—	—	—	—
		1.5	94V-0	130	130	130	2	4	—	—	—	—
E4008	NC, WT, BK	3.0	94V-0	130	130	130	1	4	0	5	4	—
		0.30	94V-0	130	130	130	—	—	—	—	—	—
		0.75	94V-0	220	180	220	3	4	—	—	—	—
E4010	NC, BK	1.5	94V-0	220	200	240	2	4	—	—	—	—
		3.0	94V-0	220	200	240	1	4	0	5	4	—
		0.30	94V-0	130	130	130	—	—	—	—	—	—
E400(Y)L, E4008L	NC, BK	0.75	94V-0	130	130	130	—	—	—	—	—	—
		1.5	94V-0	130	130	130	3	4	—	—	—	—
		3.0	94V-0	130	130	130	2	4	—	—	—	—
E4810	NC, BK	0.30	94V-0	130	130	130	1	4	0	5	4	—
		0.75	94V-0	130	130	130	—	—	—	—	—	—
		1.5	94V-0	130	130	130	0	4	—	—	—	—
		3.0	94V-0	130	130	130	0	4	—	—	—	—
		3.0	94V-0	130	130	130	1	4	0	5	4	—

(X) Denotes any number 1 thru 9.
 (Y) Denotes any number 1 thru 7.



RoHS Compliant

NOTE : Specifications subject to change without notice. Please check our website for latest information.

01.05.2008



SUPERWORLD ELECTRONICS (S) PTE LTD