

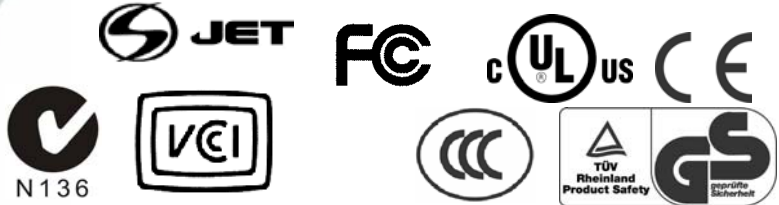

Single Port 15.4W Power Over Ethernet Adapter PSA16U IEEE 802.3af compliant



Features

- Fully Compliant with IEEE802.3af
- Diagnostic LEDs
- Non-Vented Case
- IOL Test Report
- Full Protection OTP, OCP, OVP
- Data and Power carried over one Ethernet Cable

Applications

- IP Telephones
- Wireless Network Access Points
- Blue Tooth Access Point
- Security Camera
- IP Print Servers

Safety Approvals

- cUL/UL
- CE
- CCC
- S-Jet
- TUV
- FCC
- SAA

Mechanical Characteristics

- Length: 140mm (5.51in)
- Width: 65mm (2.55in)
- Height: 36mm (1.42in)
- Weight: 0.2Kg (0.44lb.)

Output Specifications

Model	DC Output Voltage	Load		Regulation	
		Min.	Max.	Line	Load
PSA16U-480(POE)	48V	0A	0.35A	±4%	

Ripple And Noise*	Vp-p*
<500Hz	0.5
500Hz-150KHz	0.15
150KHz-500KHz	0.15
500KHz-1MHz	0.1

*As per IEEE802.3af Table 33-5. For Legacy detection or AC disconnect please contact the factory.

Phihong is not responsible for any error and change. Content is subject to change without notice. Please consult the factory and visit www.phihong.com for the most up-to-date specifications.

INPUT:

AC Input Voltage Range
90 to 264VAC

AC Input Voltage Rating
100 to 240VAC

AC Input Current
0.5A(RMS) max. for 90VAC
0.35A(RMS) max. for 240VAC

Leakage Current
0.25mA max. @ 254VAC 60Hz

AC Input Frequency
47-63Hz

AC Inrush Current
15A(RMS) max. for 115VAC
20A(RMS) max. for 230VAC

OUTPUT:

Total Output Power
15.4W

Efficiency
65% (typical) at Max. load, and 120VAC 60Hz

Hold-up Time
16mS min. 120VAC and max. load

Transient O/P Voltage Protection
60V max. at switch on and off at any AC line Phase

ENVIRONMENTAL:

Temperature

Operation 0 to +40°C
Non-operation -25 to +65°C

Humidity

Operation 5 to 90%

EMC

FCC Part 15 Class B
EN55022 Class B
VCCI, C-Tick

Isolation Test

Primary to Secondary: 3000VAC for 1 minute 10mA
Primary to F.G.: 1500VAC for 1 minute
Output to F.G.: 1500VAC

Immunity EN50082-1

ESD: EN61000-4-2. Level 3
RS: EN61000-4-3. Level 2
EFT: EN61000-4-4. Level 2
Surge: EN61000-4-5. Level 3
CS: EN61000-4-6. Level 2
Voltage Dips EN61000-4-11
Harmonic: EN61000-3-2

Insulation Resistance

Primary to secondary: >10M OHM 500VDC
Primary to FC: >10M OHM 500VDC

FEATURE:

Over Voltage/Current, Short Circuit Protection

Outputs equipped with short circuit protection and overload protection as per 802.3af specification
The output can be shorted permanently without damage

Indicators

Led #1 indicator for input power “on” GREEN
Led #2 Indicator for fault-RED
Led #3 Indicator that Detected and Connected to valid IEEE802.3af load-GREEN

Input Connector

IEC320 inlet 3 pin

Dimension Diagram Unit: mm (inch)

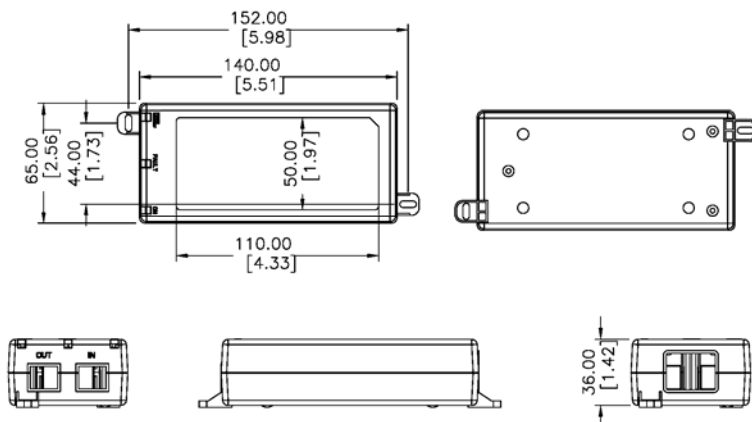

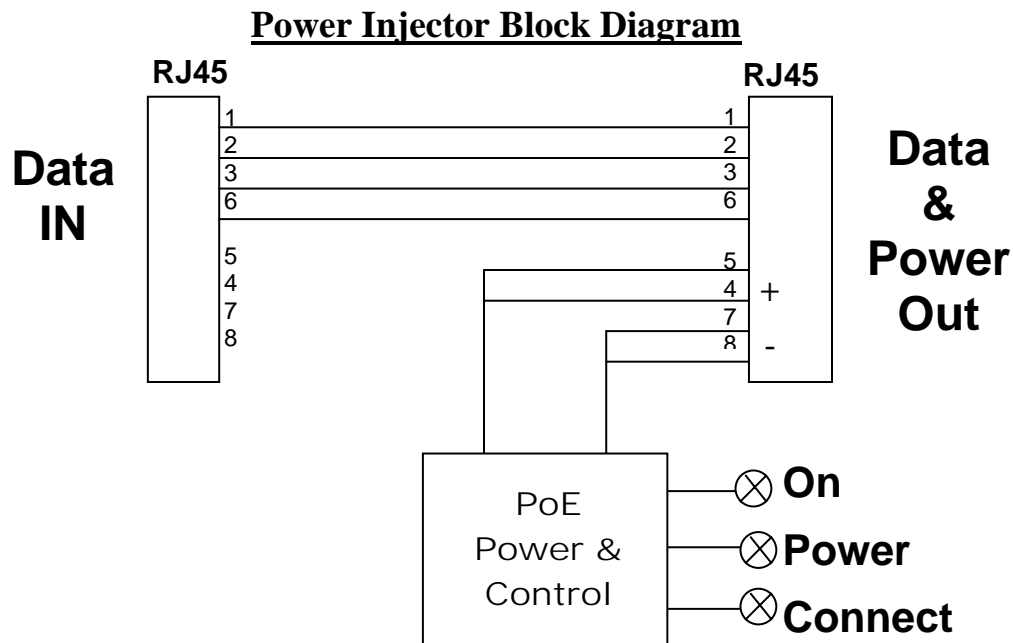

Description of LED Functions for Power Injector

Power-up Sequence:

Upon power-up, all 3 LEDs will light for 2 seconds, as part of the self-test for the internal microprocessor software. After the end of the 2 seconds, the "ON" LED will illuminate green, signifying that the DC output voltage is available for powering a compliant load (to the 802.3af PoE standards).

Detection Sequence:

Once a compliant load is attached to the output RJ45 connector, the green "CONNECT" LED will illuminate.

Should the load be non-compliant then the LEDs will blink a code signifying the cause for non-detection.

Detection Failure Codes:

1. Incorrect resistive signature - The green "CONNECT" and red "FAULT" LEDs will blink 3 times.
2. Incorrect capacitive signature - The green "ON" LED will blink 3 times.
3. Incorrect Voffset - The green "CONNECT" and green "ON" LEDs will blink 3 times.
4. Unstable current measurement - The green "ON" LED will blink 3 times
5. Low voltage sensed during detection (overload) - The red "FAULT" LED will blink 3 times

After the LEDs blink 3 times the Power Injector will continue to try to detect a valid load. Therefore, until the correct load is applied, the LEDs will continue to blink. If there is an open circuit connected to the output RJ45 then the LEDs will not blink but the Power Injector will continue to try to detect a valid load.

Fault Sequence:

Should there be a fault such as an overload or short circuit then the red "FAULT" LED will illuminate. The red "FAULT" LED will illuminate for 2 seconds and then go off as the power supply tries to re-detect a valid load. If there is a problem in detecting, the LED will indicate what is wrong with the load as per the codes in the section above.