

SMD Type Reflective Photo Sensor Subminiature Photointerrupter

MIR-3307-TC11

Description

The MIR-3307-TC11 consists of a Gallium Arsenide infrared emitting diode and a NPN silicon phototransistor built in a black plastic housing. It is a reflective subminiature photointerrupter.

Package Dimensions

Unit: mm

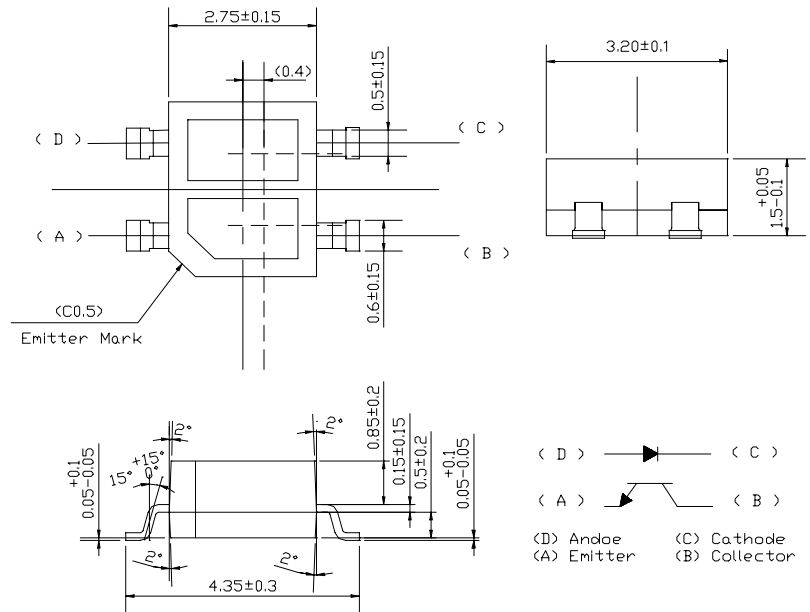

Features

- Compact and thin
- MIR-3307-TC11 : Compact DIP, SMD type
- Optimum detecting distance : 0.8 - 1.0 mm
- Wavelength : 940nm
- Visible light cut-off type

NOTE:
(1). Tolerance: ±0.2mm
(2). () Reference dimensions

Item	Content	
Lead Material	The Cu System	
Mold Material	Inner: Epoxy Resin	Outer: PPA

Absolute Maximum Ratings

@ T_A=25°C

Parameter		Symbol	Minimum Rating	Maximum Rating	Unit
INPUT	Continuous Forward Current	I _F	-	50	mA
	Reverse Voltage	V _R	-	5	V
	Power Dissipation	P _{ad}	-	80	mW
OUTPUT	Collector-emitter breakdown voltage	V _{(BR)CEO}	30	-	V
	Emitter-Collector breakdown voltage	V _{(BR)ECO}	5	-	V
	Collector power dissipation	P _C	-	75	mW
Total power dissipation		P _{TOT}	-	100	mW
Operating Temperature Range		T _{opr}	-40°C to + 85°C		
Storage Temperature Range		T _{stg}	-40°C to + 85°C		
Lead Soldering Temperature (minimum 1.6mm from body) at 300°C within 2 sec					

Optical-Electrical Characteristics

@ T_A=25°C

	Parameter	symbol	Min.	Typ.	Max.	Unit.	Test Conditions
Input	Forward Voltage	V _F	-	1.2	1.4	V	I _F =20mA
	Reverse Current	I _R	-	-	10	μA	V _R =3V
	Capacitance	C _o	-	25	-	pF	V _R =0V, f=1MHz
Output	Collector Dark Current	I _{ceo}	-	-	100	nA	V _{ce} =20V
	Capacitance	C _{CE}	-	10	-	pF	V _{CE} =5V, f=1MHz
Transfer Characteristics	*1 Collector Current	I _c	45	110	360	μA	I _F =4mA, V _{ce} =3V
	Response Time (RISE)	t _r	-	20	100	μS	I _c =100μA, V _{ce} =2V
	Response Time (FALL)	t _f	-	20	100	μS	R _L =1kΩ, d=1mm
	*2 Leak Current	I _{LEAK}	-	-	0.1	μA	I _F =4mA, V _{ce} =3V
	Saturation Voltage	V _{CE(set)}	-	-	0.4	V	I _F =20mA, I _c =0.1mA

*1 THE CONDITION AND ARRANGEMENT OF THE REFLECTIVE OBJECT ARE SHOWN AS FOLLOWING .

*2 WITHOUT REFLECTIVE OBJECT.

TEST CONDITION AND ARRANGEMENT FOR COLLECTOR CURRENT

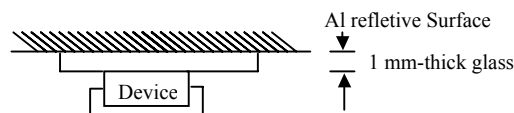

Typical Optical-Electrical Characteristic Curves

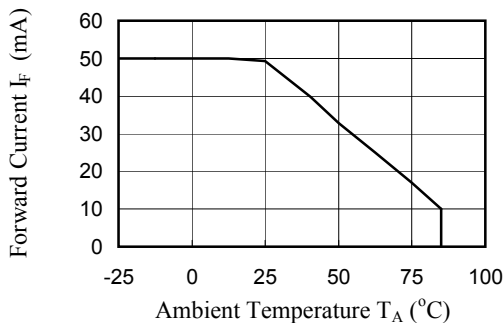

Fig.1 forward Current vs. Ambient Temperature

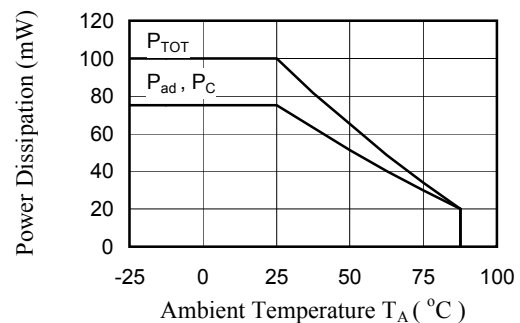

Fig.2 Power Dissipation vs. Ambient Temperature

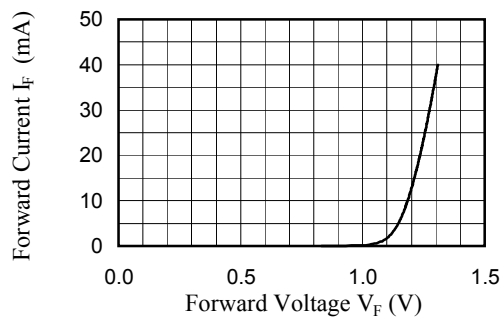

Fig.3 Forward Current vs Forward Voltage

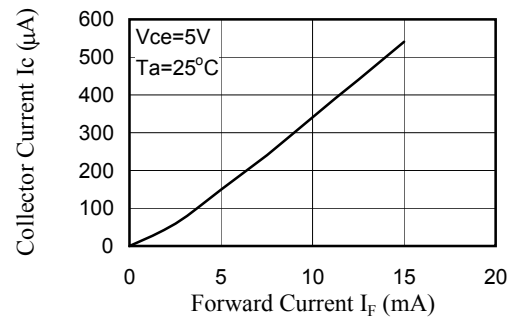

Fig.4 Collector Current vs. Forward Current

Typical Optical-Electrical Characteristic Curves

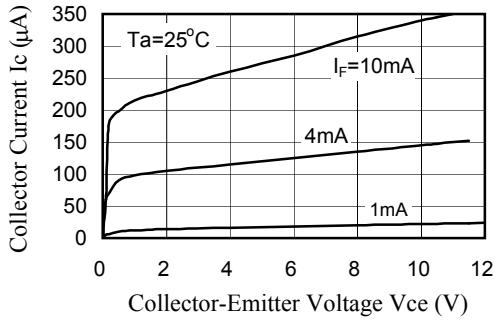

Fig.5 Collector Current vs. V_{ce}

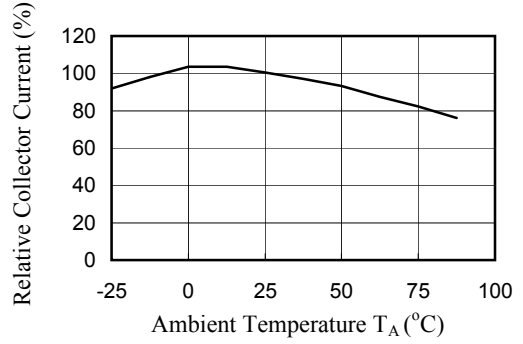

Fig.6 Relative Collector Current vs.

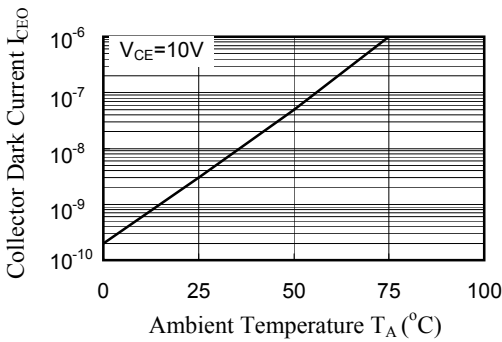

Fig.7 Collector Dark Current vs. Ambient Temperature

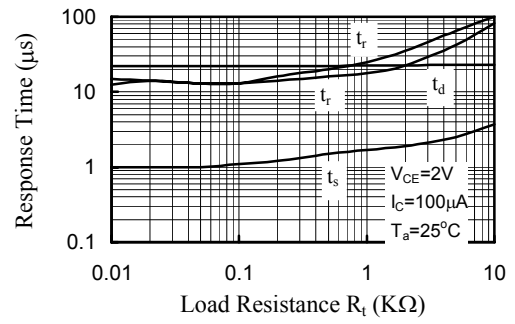

Fig.8 Response Time vs. Load Resistance

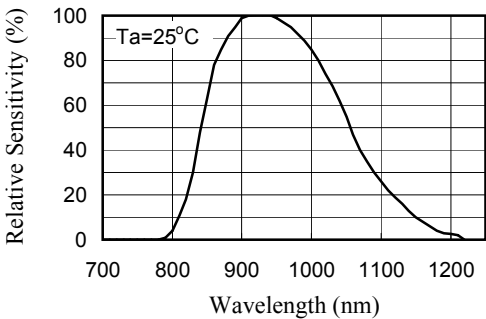

Fig.9 Spectral Sensitivity (Detecting side)

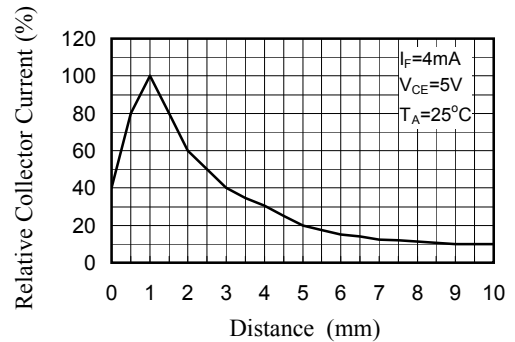
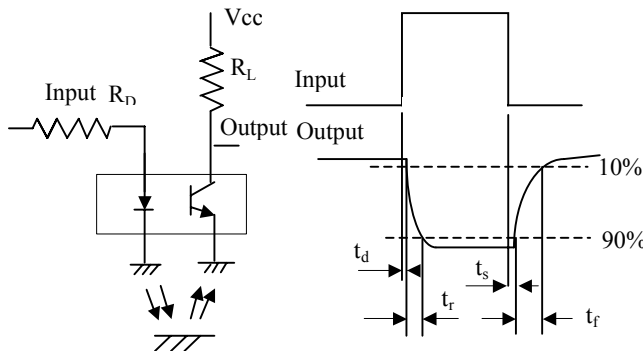

Fig.10 Relative Collector Current vs. Distance between MIR-3307 and Card

Test Circuit for Response Time



Reliability Test Item

Test Item	Description and Test Condition	Reference Standard	Judgement
Operation Life	Evaluates resistance of the device when operated at electrical stress Ta=under room temperature Test Time=1000hrs (-24hrs,+72hrs)	MIL-STD-750:1026 MIL-STD-883:1005 JIS C 7021:B-1	ACCEPT: Power Decay <30%
High Temperature High Humidity	Evaluates moisture resistance of the device when stored for a long term at high temperature and high humidity Ta=85±5 °C Rh=85±5%Rh Test Time=1000hrs (-24hrs,+72hrs)	MIL-STD-202:103B JIS C 7021:B-11	ACCEPT: None is OPEN/SHORT
High Temperature Storage	Evaluates device durability for long term storage in high temperature Ta=105 °C Test Time=1000hrs(-24hrs,+72hrs)	MIL-STD-883:1008 JIS C 7021:B-10	ACCEPT: None is OPEN/SHORT
Low Temperature Storage	Evaluates device durability for long term storage in low temperature Ta=-55°C Test Time=1000hrs(-24hrs,+72hrs)	JIS C 7021:B-12	ACCEPT: None is OPEN/SHORT
Temperature Cycling	Evaluates resistance of device at thermal stresses or expansion and contraction 105°C ~ 25°C ~ -55°C ~ 25°C 30min 5min 30min 5min 20 Cycles	MIL-STD-202:107D MIL-STD-750:1051 MIL-STD-883:1010 JIS C 7021:A-4	ACCEPT: None is OPEN/SHORT
Thermal Shock	Evaluates device's structure and mechanical resistance when suddenly exposed at severe changes 105°C ~ -55°C 10min 10min 10 Cycles	MIL-STD-202:107D MIL-STD-750:1051 MIL-STD-883:1011	ACCEPT: None is OPEN/SHORT
Reflow Soldering Heat Resistance Test	Reflow process : Condition is as follow page. Less than 2 time.	MIL-STD-202:210A MIL-STD-750:2031 JIS C 7021:A-1	ACCEPT: None is OPEN/SHORT
Solderability	Evaluates solderability on leads of device T.Sol=230°C Dwell Time=5 sec	MIL-STD-202:208D MIL-STD-750:2026 MIL-STD-883:2003 JIS C 7021:A-2	ACCEPT: 95% soldering area on the lead frame
Pressure Cooker Test	Phase1:110oC, 85%RH, 1.242kgf/cm ² Phase2:130oC, 85%RH,2.714kgf/cm ²	-	ACCEPT: None is OPEN/SHORT
Drop Test	Distance of Dropping : 1 m Drop the Device on the Maple Board 3 Times	-	ACCEPT: None is OPEN/SHORT

RECOMMENDED SOLDERING CONDITION

1. Reflow Soldering.

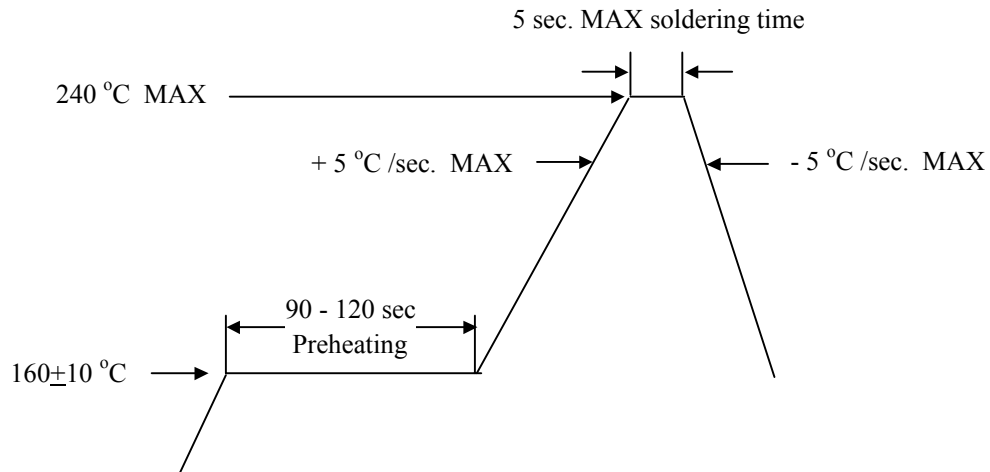

- 1.a The above temp. profile shall be at the surface of LED resin.
- 1.b Number of reflow process should be less than 2 times. If the second reflow process is performed, intervals between the first and the second process should be as short as possible to prevent moisture absorption from LED resin. Cooling process to normal temp. is required between the first and the second reflow process.
- 1.c Temp. fluctuation to LED at pre-heat process should be minimized. (less than 6°C)

2. Dip Soldering.

- 2.a Preheat temp. for soldering : $120 - 150^\circ\text{C}$, 60 - 120 sec.
- 2.b Soldering temp.: Temp. of soldering pot 300°C Max and soldering time less than 2 sec.
- 2.c Number of dip soldering process must be less than 2 times and the process is performed in sequence. Cooling process to normal temp. will be required between the first and the second soldering process.

MIR-3307-TC11

Tape Dimensions

Unit:mm

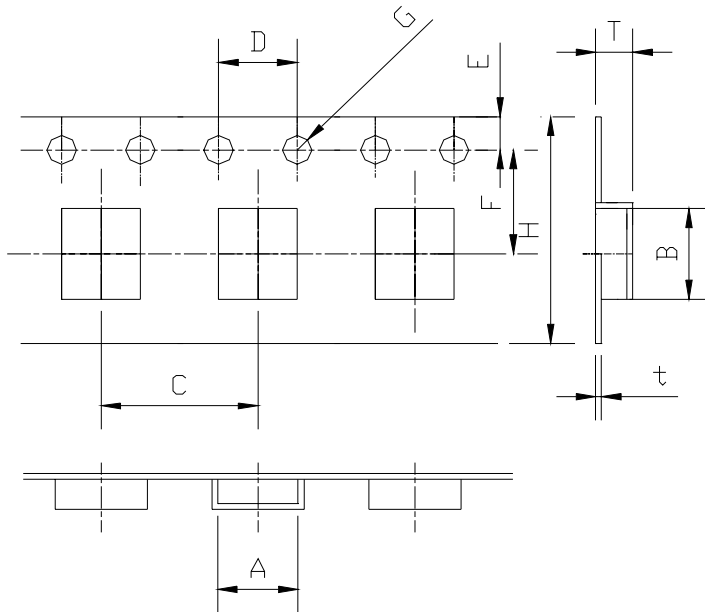

Tape Material: PET

Symbol	Dimension
A	3.50±0.1
B	5.55±0.1
C	8.00±0.2
D	4.00±0.1
E	1.75±0.1
F	5.50±0.1
G	φ 1.50+0.1,-0
H	12.00±0.3
T	1.95±0.1
t	0.25+0.1,-0.05

REEL Dimensions

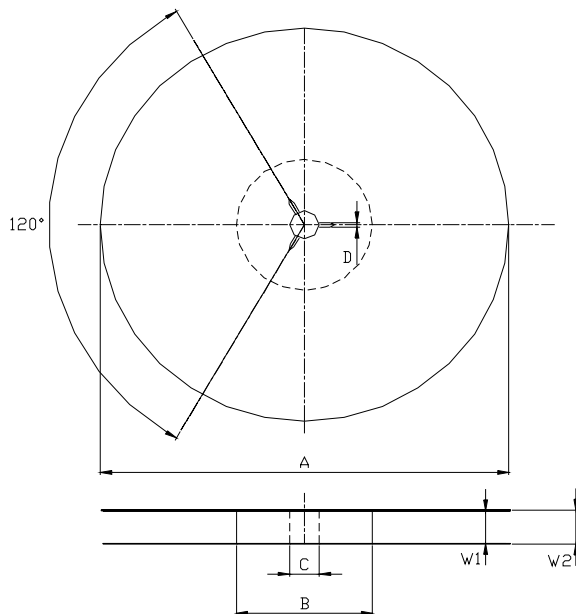

Reel Material : PS

Symbol	Dimension
A	φ 180.0+0,-3
B	φ 60.0+1,-0
C	φ 13.0±0.2
D	2.0±0.5
W1	13.0±0.3
W2	15.4±1.0

Quantity : 1000pcs

UNI

Unity Opto Technology Co., Ltd.

11/06/2003

Taping Construction

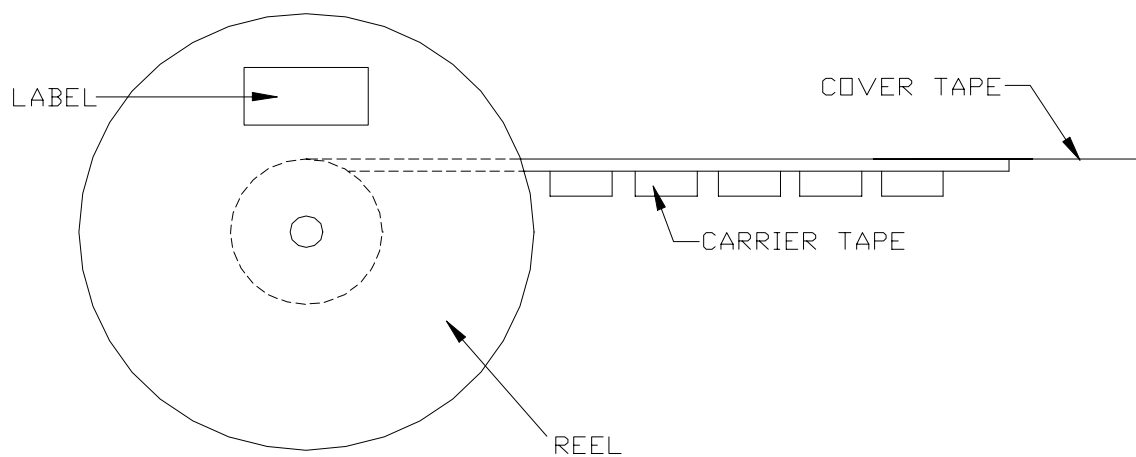
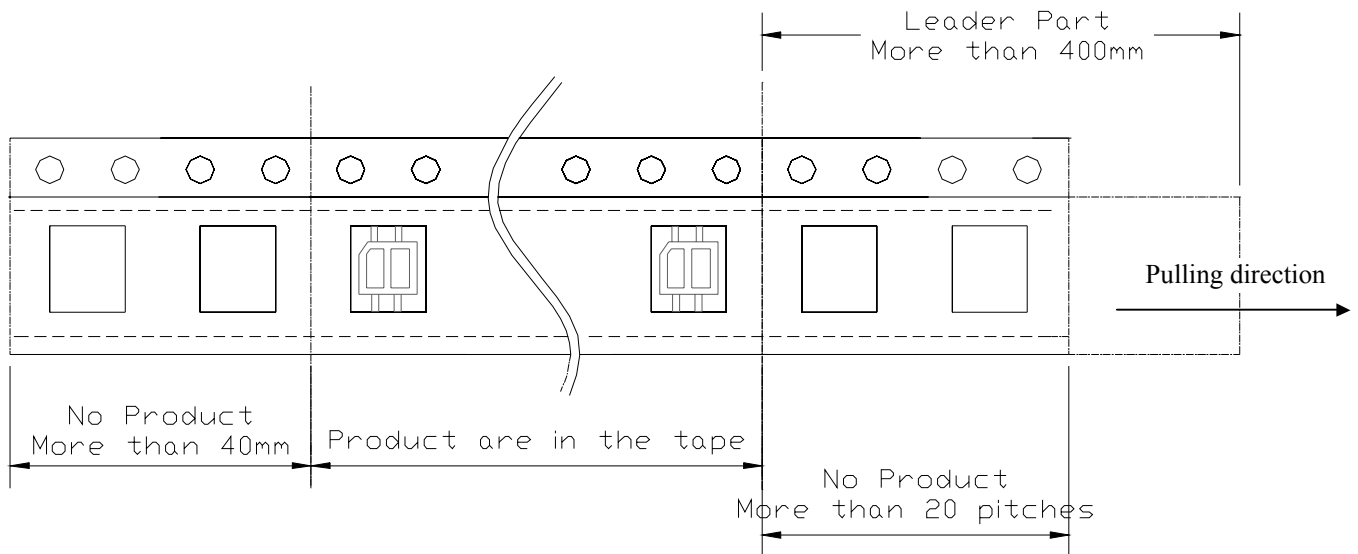

1. The sprocket holes shall be on the left side against the pull-out direction.
2. The space of more than 20 pitches shall be provided on each front of tape mounting.
3. The space of more than 40 mm shall be provided on each rear of tape mounting.
4. The leader of more than 400 mm by the cover tape shall be provided at the pull-out start portion.

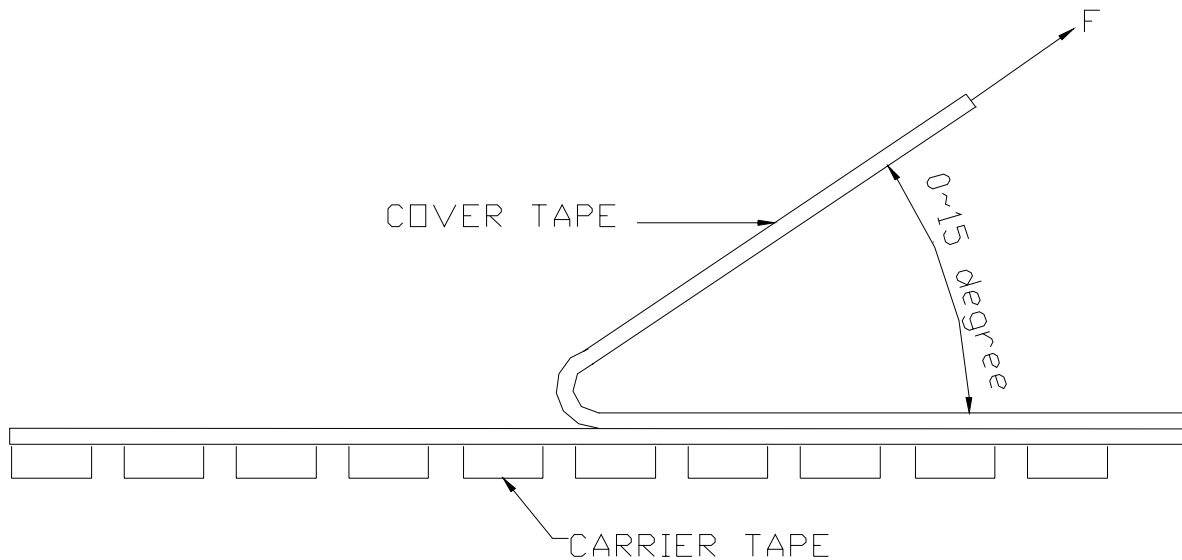
Taping Mechanical characteristics and specifications**1. Peeling strength of cover tape :**

(1). $F=0.2\sim0.7N(20\sim70gf)$ (measure by tension gage)

(2). Tape should not be burst by peeling.

2. Specifications :

(1). When the tape is bent to radius 30 mm, products do not fall down from the tape and tape doesn't get any damage.

(2). During the peeling, products do not fix to cover tape.

(3). The product which was enclosed in reverse direction or with back side up should be count as 0pcs/reel. The number of dropped parts should be 0.1% reel.

MIR-3307-TC11

Tolerance ± 10 mm

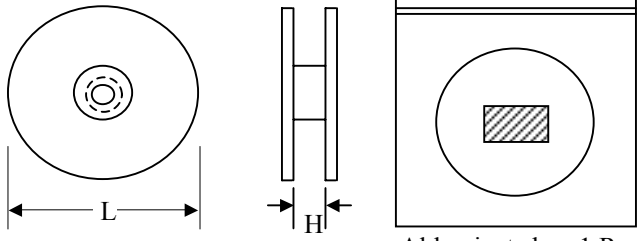
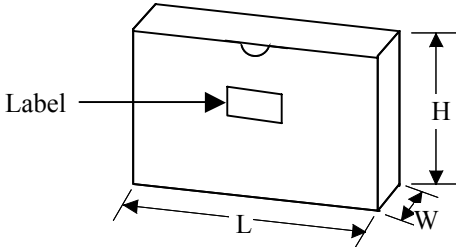
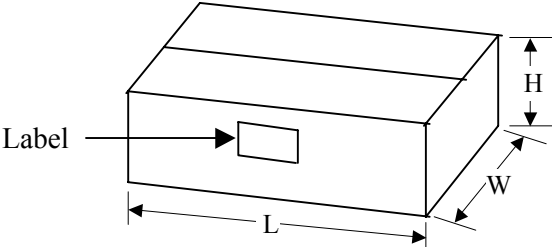
 <p>Al laminate bag:1 Reel</p>	<p>H : 13 mm</p> <p>L : 180 mm</p> <p>PCS/Reel 1000pcs</p>
<p>4 REELS/INNER BOX</p> 	<p>H : 190 mm</p> <p>L : 190 mm</p> <p>W : 75 mm</p> <p>PCS/INNER BOX 4000pcs</p>
<p>10 INNER BOXES/OUTER BOX</p> 	<p>H : 215 mm</p> <p>L : 415 mm</p> <p>W : 400 mm</p> <p>PCS/OUTER BOX 40000pcs</p>

PACKAGE LABEL



Customer P/C:		
UNI P/N: MIR-3307-TC11		
Bin Attribution:		
Quantity:	1000	
Lot No.:		

Unity Opto Technology Co., Ltd.
 10F, No. 88-8, Sec.1, Kuang-Fu Rd., Sanchung City, 241, Taipei, Taiwan. www.unityopto.com.tw