

Structure	Silicon Monolithic Integrated Circuit
Product Series	6ch Power Driver for Car Audio
Type	BD8215EFV
Feature	<ul style="list-style-type: none"> • The SPINDLE driver and the SLED driver can highly effective drive with PWM drive system. • The actuator driver and the loading driver are linear BTL drive and are achieving a low noise power.

Absolute maximum ratings(Ta=25)

Parameter	Symbol	Limits	Unit
POWER MOS power supply voltage	SPVM, SPRNF, SLRNF	15 #1	V
Pre-block / BTL / Loading driver power-block power supply voltage	Vcc, VMFCRNF, VMTKRNF, VM_S	15	V
Input terminal voltage1	VIN1 #2	VCC	V
Input terminal voltage2	VIN2 #3	VM_S	V
Power dissipation	Pd	2.0 #4	W
Operating temperature range	Topr	-40 ~ 85	
Storage temperature	Tstg	-55 ~ 150	
Junction temperature	Tjmax	150	

#1 POWER MOS output terminals are contained.

#2 It shows each terminal of CTL1 , CTL2 , Vc , ACTMUTE , LDIN , TINN , and FINN.

#3 It shows each terminal of HU+ , HU- , HV+ , HV- , HW+ , HW- , SL1INN , SL2INN , SPIN , SPVM , and VM_S.

#4 Ta=25 , PCB (70mm x 70mm x 1.6mm,occupied copper foil is less than 3%,glass epoxy standard board) mounting.
Reduce power by 16mW for each degree above 25 .

Operating conditions (Ta=-40 ~ +85)

(Set the power supply voltage taking allowable dissipation into considering.)

Parameter	Symbol	MIN	TYP	MAX	Unit
Pre-block / Loading driver power-block power supply voltage	Vcc	6	8	10	V
PWM-part Pre-block power supply voltage	VM_S	6	8	Vcc	V
Spindle driver powerblock power supply voltage	SPVM, SPRNF	6	8	VM_S	V
Sled motor driver powerblock power supply voltage	SLRNF	6	8	VM_S	V
Actuator driver powerblock Power supply voltage	VMFCRNF VMTKRNF	4	8	Vcc	V

Install detect resistance between SPVM, SPRNF, SLRNF and VM_S, and between VMFCRNF, VMTKRNF and AVM.

Status of this document

The Japanese version of this document is the formal specification. A customer may use this translation version only for a reference to help reading the formal version. If there are any differences in translation version of this document, formal version takes priority.

Be careful to handle because the content of the description of this material might correspond to the labor (technology in the design, manufacturing, and use) in foreign country exchange and Foreign Trade Control Law.

A radiation is not designed.

Electrical characteristics

(Unless otherwise noted, Ta=25 , Vcc=SPVM=SLRNF=VM_S=8V, AVM=8V, Vc=1.25V, RL=8 , RLSP=2 ,SPRNF=0.165 ,SLRNF=0.5)

Parameter		Symbol	MIN.	TYP.	MAX.	Unit	Condition	
Circuit current	Quiescent current	I _Q	-	18	25	mA		
	Standby-on current	I _{ST}	-	0.7	1.0	mA	CTL1= CTL2=0V	
Spindle driver Block	Hall bias	Voltage of hall bias	V _{HB}	0.45	0.9	1.35	V	IHB = 10mA
		Input bias current	I _{HB}	-5	-	5	μA	
	Hall AMP	Input level	V _{HIM}	50	-	-	mVpp	
		Common mode input range	V _{HQM}	1	-	6	V	
		Input dead zone (one side)	V _{DZSP}	0	10	40	mV	
	Torque instruction I/O	Input output gain	gm _{SP}	1.06	1.37	1.64	AV	
		Output On resistor (Vertical harmony)	R _{ONSP}	-	1	1.8	Ω	IL = 500mA
		Output limit current	I _{LNSP}	0.8 (0.132)	1.0 (0.165)	1.2 (0.198)	A (V)	
		Input impedance	R _{INSP}	35	47	59	kΩ	
		PWM frequency	f _{SP}	-	100	-	kHz	
FG output	Low voltage	V _{FGL}	-	0.1	0.3	V	10KΩ Pull-up (3.3V)	
	Input dead zone (one side)	V _{DZSL}	5	30	55	mV		
Stepping motor driver Block	Input output gain	gm _{SP}	1.02	1.32	1.62	AV		
	Input offset voltage	V _{DZSL}	-5	-	5	mV		
	Input bias current	I _{BASSL}	10	50	300	nA		
	Output On resistor (Vertical harmony)	R _{ONSL}	-	2.2	3.7	Ω	IL = 500mA	
	Output limit current	I _{LNSL}	0.84 (0.42)	1.0 (0.5)	1.16 (0.58)	A (V)		
	PWM frequency	f _{SP}	-	100	-	kHz		
Actuator driver Block	Input offset voltage	V _{ONACT}	-5	-	5	mV		
	Input bias current	I _{BASACT}	10	50	300	nA		
	Output offset voltage	V _{OFF}	-50	0	50	mV	Excluding pre-op amp	
	Output saturation voltage (vertical harmony)	V _{OFF}	-	1.5	2.3	V	IL = 500mA	
	Voltage gain	G _{MFT}	14.1	15.6	17.1	dB		
Loading driver Block	Output offset voltage	V _{OFFD}	-75	0	75	mV		
	Output saturation voltage (vertical harmony)	V _{OLD}	-	1.5	2.3	V	IL = 500mA	
	Input impedance	R _{OLD}	35	47	59	kΩ		
	Voltage gain	G _{MVD}	17.1	18.7	20.3	dB	LDIN series resistance = 2kΩ	
Picking up protection circuit Block	PRTT/PRTF Default voltage	V _{PRTRREF}	1.00	1.06	1.12	V		
	PRTT/PRTF Protection detection voltage	V _{PRTRDET}	2.82	3.00	3.18	V		
	PRTLIM Voltage	V _{PRTRLM}	500	530	560	mV		
	DETAMP Input offset voltage	V _{OFFDET}	-5	0	5	mV		
Picking up protection reset Block	L output voltage	V _{OL}	-	0.1	0.3	V	33KΩ Pull-up (3.3V)	
Actuator mute Input	H input voltage	V _{AH}	2	-	-	V		
	L input voltage	V _{AL}	-	-	0.8	V		
CTL1,CTL2	L input voltage	V _{CTL}	-	-	0.8	V		
	H input voltage	V _{CTH}	2	-	-	V		
	Highlevel input current	I _{CTH}	-	50	100	μA	CTL = 3.3V	
Function	Vc drop muting Voltage of mute	V _{MNG}	0.4	0.7	1	V		
	Vcc drop muting Voltage of mute	V _{MNC}	3.4	3.8	4.2	V		
	Vc input current	I _{CG}	-	4	8	μA		

Package outlines : HTSSOP-B54

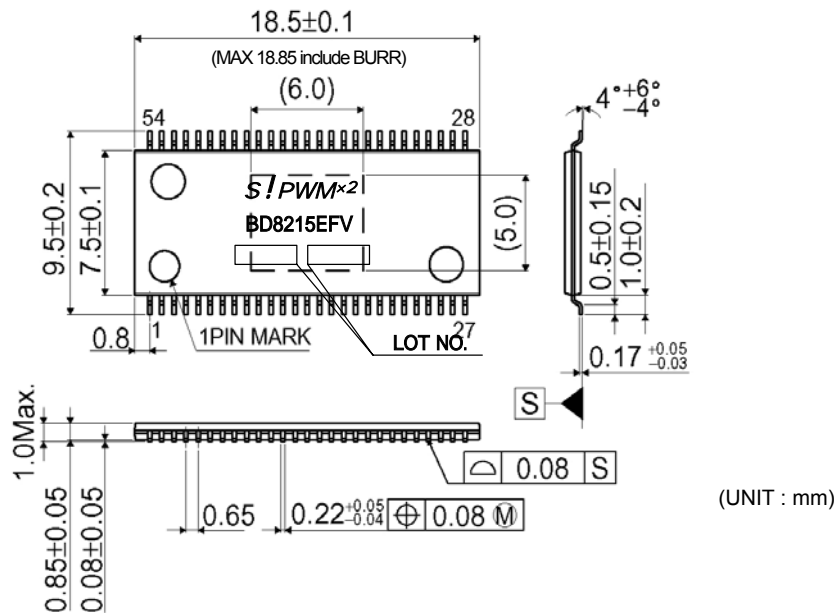

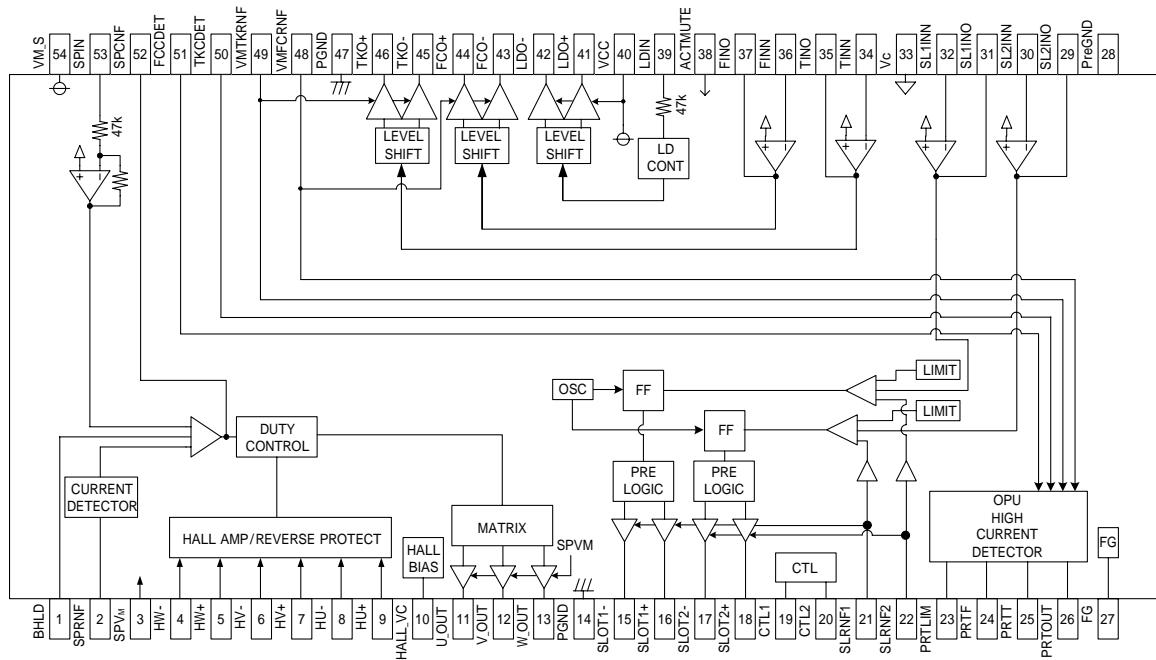

About input / output polarity, FCO+=L, FCO-=H at FINO > Vc.
Same applies to SL1INO, SL2INO, TINO.

Pin description

No.	Symbol	Description	No.	Symbol	Description
1	BHLD	Spindle driver current sense bottom hold	54	VM_S	Spindle / Sled control block power supply
2	SPRNF	Spindle driver current sense	53	SPIN	Spindle driver input
3	SPVM	Spindle driver power supply	52	SPCNF	Spindle driver loop filter
4	HW-	Hall amp.W negative input	51	FCCDET	Drive current detect for Focus drive
5	HW+	Hall amp.W positive input	50	TKCDET	Drive current detect for Tracking drive
6	HV-	Hall amp.V negative input	49	VMTKRNF	Tracking driver power supply
7	HV+	Hall amp.V positive input	48	VMFCRNF	Focus driver power supply
8	HU-	Hall amp.U negative input	47	PGND	Act / LD driver power ground
9	HU+	Hall amp.U positive input	46	TKO+	Tracking driver positive output
10	HALL_Vc	Hole bias	45	TKO-	Tracking driver negative output
11	U_OUT	Spindle driver output U	44	FCO+	Focus driver positive output
12	V_OUT	Spindle driver output V	43	FCO-	Focus driver negative output
13	W_OUT	Spindle driver output W	42	LDO-	Loading driver negative output
14	PGND	Spindle & SLED driver block power ground	41	LDO+	Loading driver positive output
15	SLO1-	Sled driver 1 negative output	40	Vcc	BTL pre and Loading power supply
16	SLO1+	Sled driver 1 positive output	39	LDIN	Input for Loading driver
17	SLO2-	Sled driver 2 negative output	38	ACTMUTE	Focus · Tracking driver mute terminal
18	SLO2+	Sled driver 2 positive output	37	FINO	Output for Focus driver pre-op amp
19	CTL1	Driver logic control input 1	36	FINN	Inverted input for Focus driver pre-op amp
20	CTL2	Driver logic control input 2	35	TINO	Output for Tracking driver pre-op amp
21	SLRNF1	Sled driver 1 current sense	34	TINN	Inverted input for Tracking driver pre-op amp
22	SLRNF2	Sled driver 2 current sense	33	Vc	Reference voltage input
23	PRTLIM	Droop current setting for Pick-up protect	32	SL1INN	Inverted input for Sled driver 1 pre-op amp
24	PRTF	Protect Time setting for Focus	31	SL1INO	Output for Sled driver 1 pre-op amp
25	PRTT	Protect Time setting for tracking	30	SL2INN	Inverted input for Sled driver 2 pre-op amp
26	PRTOUT	Protect output	29	SL2INO	Output for Sled driver 2 pre-op amp
27	FG	FG output	28	PreGND	Pre block ground

Cautions in using the IC

1. Absolute maximum ratings

We are careful enough for quality control about this IC. So, there is no problem under normal operation, excluding that it exceeds the absolute maximum ratings. However, this IC might be destroyed when the absolute maximum ratings, such as impressed voltages or the operating temperature range, is exceeded, and whether the destruction is short circuit mode or open circuit mode cannot be specified. Please take into consideration the physical countermeasures for safety, such as fusing, if a particular mode that exceeds the absolute maximum rating is assumed.

2. Reverse polarity connection

Connecting the power line to the IC in reverse polarity (from that recommended) will damage the part. Please utilize the direction protection device as a diode in the supply line and motor coil line.

3. Power supply line

Due to return of regenerative current by reverse electromotive force, using electrolytic and ceramic suppress filter capacitors (0.1 μ F) close to the IC power input terminals (Vcc and GND) are recommended. Please note the electrolytic capacitor value decreases at lower temperatures and examine to dispense physical measures for safety.

4. GND line

Please keep the GND line the lowest potential always, and check the GND voltage when transient voltages are connected to the IC.

5. Thermal design

Do not exceed the power dissipation (Pd) of the package specification rating under actual operation, and please design enough temperature margins. This product has exposed the frame to the back side of the package, but please note that it is assumed to use heat radiation efficiency by the heat radiation for this part. Please take the heat radiation pattern on not only the surface of the substrate but also the back of the substrate widely.

6. Short circuit mode between terminals and wrong mounting

Do not mount the IC in the wrong direction and displacement, and be careful about the reverse-connection of the power connector. Moreover, this IC might be destroyed when the dust short the terminals between them or GND.

7. Radiation

Strong electromagnetic radiation can cause operation failures.

8. ASO (Area of Safety Operation)

Do not exceed the maximum ASO and the absolute maximum ratings of the output driver.

9. TSD (Thermal Shut-Down)

The TSD is activated when the junction temperature (Tj) exceeds Tjmax, and the output terminal is switched to OPEN.

The guarantee and protection of set are not purpose. Therefore, please do not use this IC after TSD circuit operates, nor use it for assumption that operates the TSD circuit.

10. Capacitor between output and GND

If a large capacitor is connected between the output and GND, this IC might be destroyed when Vcc becomes 0V or GND, because the electric charge accumulated in the capacitor flows to the output. Please set said capacitor to smaller than 0.1 μ F.

11. Inspection by the set circuit board

The stress might hang to IC by connecting the capacitor to the terminal with low impedance. Then, please discharge electricity in each and all process. Moreover, when attaching or detaching from jig in the inspection process, please turn off the power before mounting the IC, and turn on after mounting the IC, and vice versa. In addition, please take into consideration the countermeasures for electrostatic damage, such as giving the earth in assembly process, transportation or preservation.

12. Input terminal

This IC is a monolithic IC, and has P⁺ isolation and P substrate for the element separation. Therefore, a parasitic PN junction is formed in this P-layer and N-layer of each element. For instance, the resistor or the transistor is connected to the terminal as shown in the figure below. When the GND voltage potential is greater than the voltage potential at Terminal A on the resistor, at Terminal B on the transistor, the PN junction operates as a parasitic diode. In addition, the parasitic NPN transistor is formed in said parasitic diode and the N layer of surrounding elements close to said parasitic diode. These parasitic elements are formed in the IC because of the voltage relation. The parasitic element operating causes the interference of circuit operation, then the wrong operation and destruction. Therefore, please be careful so as not to operate the parasitic elements by impressing to input terminals lower voltage than GND (P substrate). Please do not apply the voltage to the input terminal when the power-supply voltage is not impressed. Moreover, please impress each input terminal lower than the power-supply voltage or equal to the specified range in the guaranteed voltage when the power-supply voltage is impressing.

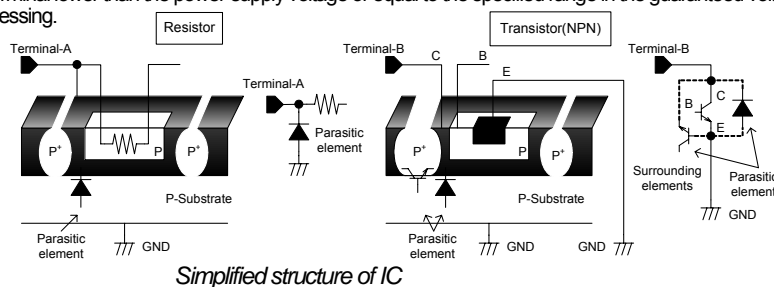

13. Earth wiring pattern

If small signal GND and large current GND exist, disperse their pattern. In addition, for voltage change by pattern wiring impedance and large current not to change voltage of small signal GND, each ground terminal of IC must be connected at the one point on the set circuit board. As for GND of external parts, it is similar to the above-mentioned.

14. Reverse-rotation braking

In the case of reverse-rotation braking from high-speed rotation, pay good attention to reverse electromotive force. Furthermore, fully check output current and consider the revolutions applied to the reverse-rotation brake.

15. About the capacitor between SPVM and PGND

The capacitor between SPVM and PGND absorbs the change in a steep voltage and the current because of the PWM drive, as a result, there is a role to suppress the disorder of the SPVM voltage. However, the effect falls by the influence of the wiring impedance etc, if the capacitor becomes far from IC. Please examine the capacitor between SPVM and PGND to arrange it near IC.

Notes

- No technical content pages of this document may be reproduced in any form or transmitted by any means without prior permission of ROHM CO.,LTD.
- The contents described herein are subject to change without notice. The specifications for the product described in this document are for reference only. Upon actual use, therefore, please request that specifications to be separately delivered.
- Application circuit diagrams and circuit constants contained herein are shown as examples of standard use and operation. Please pay careful attention to the peripheral conditions when designing circuits and deciding upon circuit constants in the set.
- Any data, including, but not limited to application circuit diagrams information, described herein are intended only as illustrations of such devices and not as the specifications for such devices. ROHM CO.,LTD. disclaims any warranty that any use of such devices shall be free from infringement of any third party's intellectual property rights or other proprietary rights, and further, assumes no liability of whatsoever nature in the event of any such infringement, or arising from or connected with or related to the use of such devices.
- Upon the sale of any such devices, other than for buyer's right to use such devices itself, resell or otherwise dispose of the same, no express or implied right or license to practice or commercially exploit any intellectual property rights or other proprietary rights owned or controlled by
- ROHM CO., LTD. is granted to any such buyer.
- Products listed in this document are no antiradiation design.

The products listed in this document are designed to be used with ordinary electronic equipment or devices (such as audio visual equipment, office-automation equipment, communications devices, electrical appliances and electronic toys).

Should you intend to use these products with equipment or devices which require an extremely high level of reliability and the malfunction of which would directly endanger human life (such as medical instruments, transportation equipment, aerospace machinery, nuclear-reactor controllers, fuel controllers and other safety devices), please be sure to consult with our sales representative in advance.

It is our top priority to supply products with the utmost quality and reliability. However, there is always a chance of failure due to unexpected factors. Therefore, please take into account the derating characteristics and allow for sufficient safety features, such as extra margin, anti-flammability, and fail-safe measures when designing in order to prevent possible accidents that may result in bodily harm or fire caused by component failure. ROHM cannot be held responsible for any damages arising from the use of the products under conditions out of the range of the specifications or due to non-compliance with the NOTES specified in this catalog.

Thank you for your accessing to ROHM product informations.

More detail product informations and catalogs are available, please contact your nearest sales office.

ROHM Customer Support System

THE AMERICAS / EUROPE / ASIA / JAPAN

www.rohm.com

Contact us : webmaster@rohm.co.jp