

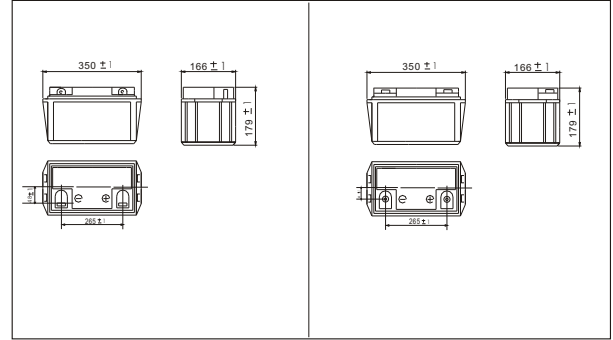

## SW12650(12V65AH)



### Outer dimensions (mm)



### Specifications

Nominal Voltage		12V
Rated capacity (10 hour rate)		65 Ah
Dimensions	Total Height	179 mm (7.05 inches)
	Height	179 mm (7.05 inches)
	Length	350 mm (13.8 inches)
	Width	166mm (6.54 inches)
Weight Approx		22 Kg (48.5 lbs)

### Terminal Type (mm)

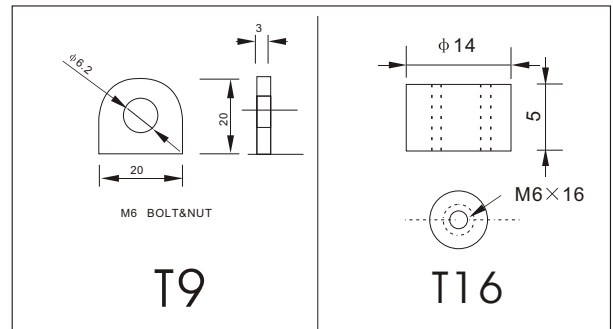

### Characteristics

Capacity 25°C(77°F)	10 hour rate(6.5 A)	65 AH
	5 hour rate(10.4 A)	52 AH
	1 hour rate(39.0 A)	39 AH
Internal Resistance	Full charged Battery at 25°C(77°F)	5.5 mΩ
Capacity affected by Temperature (10hour rate)	40°C(104°F)	102%
	25°C(77°F)	100%
	0°C(32°F)	85%
	-15°C(5°F)	65%
Self-Discharge at 25°C(77°F)	Capacity after 3 month storage	91%
	Capacity after 6 month storage	82%
	Capacity after 12 month storage	64%
Terminal		T9, T16
Charge (constant Voltage)	Cycle	Initial Charging Current less than 26 A Voltage 14.10-14.40V
	Float	Voltage 13.50-13.80V

### Discharge Curves 25°C(77°F)

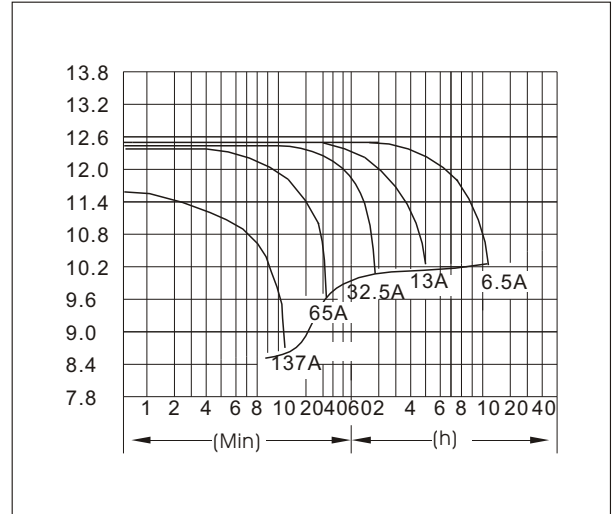

### Constant Current(Amp) and Constant Power(Watt) Discharge Table at 25°C(77°F)

Time		5min	10min	15min	30min	1h	2h	3h	4h	5h	8h	10h	20h
9.60V	A	208	137	111	74.1	39.0	22.8	16.7	13.0	10.7	7.61	6.83	3.69
	W	2149	1465	1185	797	421	250	186	146	122	87	79	42.9
10.20V	A	202	124	104	70.9	36.7	21.7	16.3	12.7	10.5	7.41	6.70	3.58
	W	2153	1382	1165	795	415	250	188	147	123	87	79	41.9
10.50V	A	195	111	91	66.3	35.5	21.2	15.9	12.5	10.4	7.35	6.57	3.58
	W	2130	1259	1039	763	411	246	185	146	122	86	78	42.3
10.80V	A	188	104	85	61.1	34.3	20.7	15.5	12.3	10.1	7.15	6.50	3.51
	W	2109	1203	975	708	399	242	182	145	120	85	77	41.8
11.10V	A	182	98	78	54.6	33.2	20.2	15.0	12.0	9.9	6.96	6.18	3.32
	W	2060	1132	909	639	390	238	178	142	118	83	74.5	40.2