

PLEASE CHECK WWW.MOLEX.COM FOR LATEST PART INFORMATION

Part Number: [0678007125](#)
Status: **Active**
Overview: [serial_ata_products](#)
Description: 1.27mm (.050") Pitch Serial ATA High Speed Header, Vertical, Through Hole, with Locking Latch, 7 Circuits, 0.38µm (15µ") Gold (Au) Plating, for 2.40mm (.079") PCB, High Temperature, Black, Footprint B, with PCB Locator Tabs, Lead-free

Documents:

[3D Model](#) [Product Specification PS-67491-001 \(PDF\)](#)
[Drawing \(PDF\)](#) [RoHS Certificate of Compliance \(PDF\)](#)

Agency Certification

CSA LR 19980
 UL E29179

General

Product Family PCB Headers
 Series [67800](#)
 Application Board-to-Board, Wire-to-Board
 Comments Staggered Solder Pin|Footprint B
 Overview [serial_ata_products](#)
 Product Name Serial ATA

Physical

Breakaway No
 Circuits (Loaded) 7
 Circuits (maximum) 7
 Color - Resin Black
 Durability (mating cycles max) 50
 First Mate / Last Break Yes
 Flammability 94V-0
 Glow-Wire Compliant No
 Guide to Mating Part No
 Keying to Mating Part Yes
 Lock to Mating Part Yes
 Material - Metal Brass
 Material - Plating Mating Gold
 Material - Plating Termination Tin
 Number of Rows 1
 Orientation Vertical
 PC Tail Length (in) 0.128 In
 PC Tail Length (mm) 3.25 mm
 PCB Locator Yes
 PCB Retention Yes
 PCB Thickness Recommended (in) 0.093 In
 PCB Thickness Recommended (mm) 2.40 mm
 Packaging Type Tray
 Pitch - Mating Interface (in) 0.050 In
 Pitch - Mating Interface (mm) 1.27 mm
 Pitch - Term. Interface (in) 0.050 In
 Pitch - Term. Interface (mm) 1.27 mm
 Polarized to Mating Part Yes
 Shrouded Fully
 Stackable No
 Surface Mount Compatible (SMC) Yes
 Temperature Range - Operating -35°C to +85°C

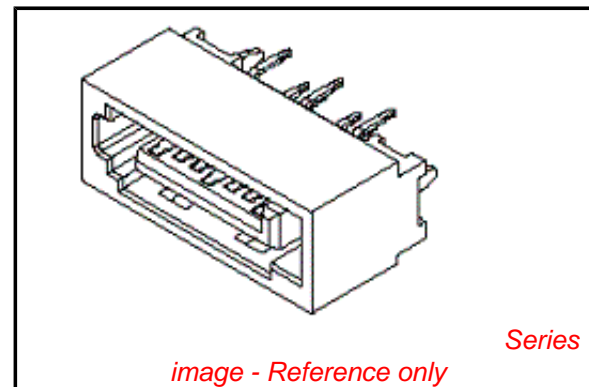

EU RoHS

ELV and RoHS Compliant
REACH SVHC
 Not Reviewed
Halogen-Free Status
Not Reviewed

China RoHS



Need more information on product environmental compliance?

Email productcompliance@molex.com
 For a multiple part number RoHS Certificate of Compliance, [click here](#)

Please visit the [Contact Us](#) section for any non-product compliance questions.

Search Parts in this Series
[67800Series](#)

Termination Interface: Style

Through Hole

Electrical

Current - Maximum per Contact

1.5A

Voltage - Maximum

15V DC

Solder Process Data

Lead-free Process Capability

SMC & Wave Capable (TH only)

Material Info

Reference - Drawing Numbers

Packaging Specification

PK-67800-001

Product Specification

PS-67491-001

Sales Drawing

SD-67800-007

This document was generated on 05/26/2010

PLEASE CHECK WWW.MOLEX.COM FOR LATEST PART INFORMATION

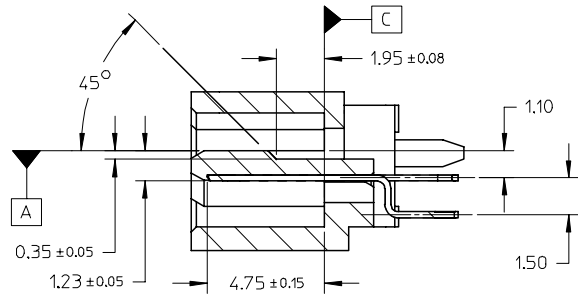
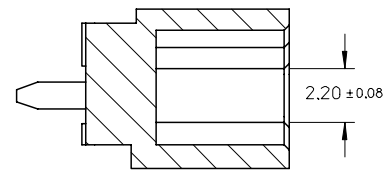
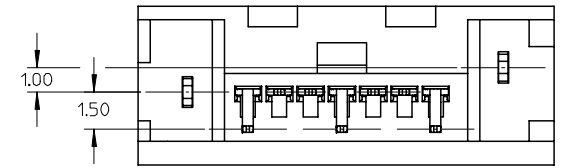
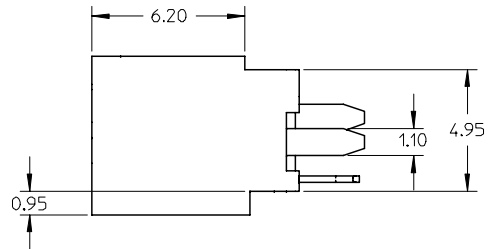
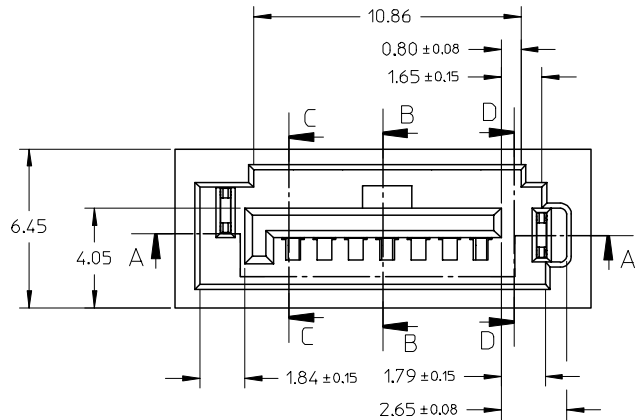
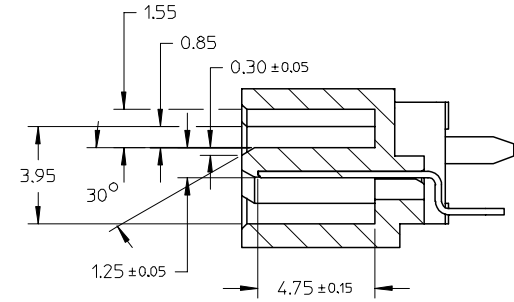
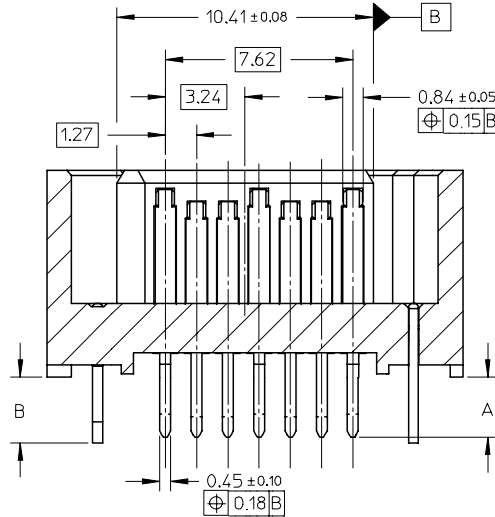
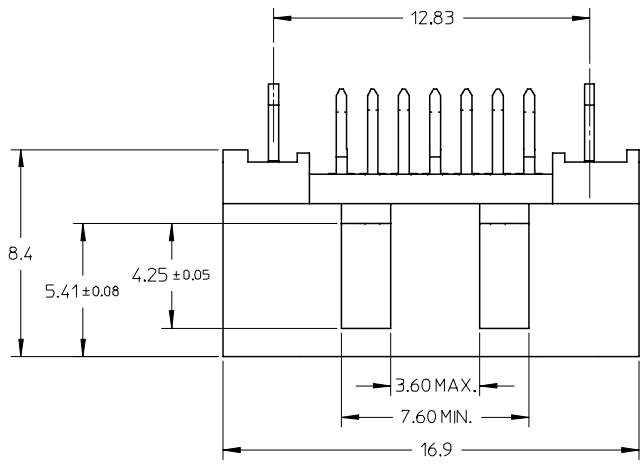

SECTION B-B

SECTION D-D

OBSOLESCE PART
 EC NO: SH2006-0566
 DRWN: BCHENZ6 2006/05/29
 CHKD: GRATE MA 2006/05/29
 APPR: JNCHEN 2006/05/30

QUALITY SYMBOLS
 $\nabla = 0$
 $\triangle = 0$

GENERAL TOLERANCES (UNLESS SPECIFIED)	
mm	INCH
4 PLACES ± ---	± ---
3 PLACES ± ---	± ---
2 PLACES ± 0.15	± ---
1 PLACE ± 0.25	± ---
ANGULAR ± 1/2°	

DRAFT WHERE APPLICABLE MUST REMAIN WITHIN DIMENSIONS

DIMENSION STYLE	
MM ONLY	
DRAWN BY	DATE
GRATE MA	2004/02/02
CHECKED BY	DATE
YAJUN	2004/02/02
APPROVED BY	DATE
SAM	2004/02/02
MATERIAL NO.	
SEE SHEET 2	

SCALE	DESIGN UNITS	THIRD ANGLE PROJECTION	
5:1	METRIC		
TITLE			
HIGH SPEED CONNECTOR 1.27MM PITCH VERTICAL DIP SOLDER TAIL			
MOLEX INCORPORATED		SHEET NO.	
DOCUMENT NO. SD-67800-007		1 OF 2	
THIS DRAWING CONTAINS INFORMATION THAT IS PROPRIETARY TO MOLEX INCORPORATED AND SHOULD NOT BE USED WITHOUT WRITTEN PERMISSION			

F

E

F

E

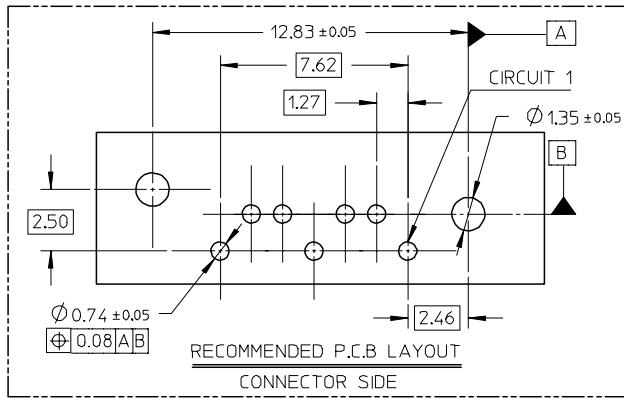

NOTES:

- MATERIAL:
HOUSING/COLOR: SEE CHART, GLASS FILLED, UL94V-0
TERMINAL/PEG: BRASS
- TERMINAL PLATING:
CONTACT AREA: (a) GOLD FLASH
(b) GOLD, THICKNESS=0.76 MICRON MINIMUM
(c) GOLD, THICKNESS=0.38 MICRON MINIMUM
- SOLDER TAIL: TIN PLATED 1.27 MICRON MINIMUM OVER NICKEL PLATED 1.27 MICRON MINIMUM
- PEG PLATING: TIN PLATED 1.27 MICRON MINIMUM OVER NICKEL PLATED 1.8 MICRON MINIMUM
- PACKAGING: TRAY
- PRODUCT SPECIFICATION REFER TO PS-67491-001
- RECOMMENDED SOLDERING PROCESS: THERMAL PLASTIC FOR WAVE SOLDEING PROCESS
HIGH TEMPERATURE THERMAL PLASTIC FOR IR SOLDERING PROCESS



D

D

678007065	SEE NOTE2(c)							
678007062	SEE NOTE2(b)	3.25	3.45	2.40+/-0.05				
678007061	SEE NOTE2(a)							
678007055	SEE NOTE2(c)							
678007052	SEE NOTE2(b)	2.85	3.05	2.00+/-0.05	THERMAL	NATURE		
678007051	SEE NOTE2(a)				PLASTIC	COLOR		
678007045	SEE NOTE2(c)							
678007042	SEE NOTE2(b)	2.45	2.65	1.60+/-0.05				
678007041	SEE NOTE2(a)							
678007085	SEE NOTE2(c)							
678007082	SEE NOTE2(b)	3.25	3.45	2.40+/-0.05				
678007081	SEE NOTE2(a)							
678007075	SEE NOTE2(c)				THERMAL	PROCESS	PURE	
678007072	SEE NOTE2(b)	2.85	3.05	2.00+/-0.05	PLASTIC	BLUE C	TIN	
678007071	SEE NOTE2(a)					ΔE<3		
678007035	SEE NOTE2(c)							
678007032	SEE NOTE2(b)	2.45	2.65	1.60+/-0.05				
678007031	SEE NOTE2(a)							
678007025	SEE NOTE2(c)							
678007022	SEE NOTE2(b)	3.25	3.45	2.40+/-0.05				
678007021	SEE NOTE2(a)							
678007015	SEE NOTE2(c)							
678007012	SEE NOTE2(b)	2.85	3.05	2.00+/-0.05	THERMAL	BLACK		
678007011	SEE NOTE2(a)				PLASTIC			
678007005	SEE NOTE2(c)							
678007002	SEE NOTE2(b)	2.45	2.65	1.60+/-0.05				
678007001	SEE NOTE2(a)							
MATERIAL NUMBER	PLATING TYPE	DIM A	DIM B	P.C.B THICKNESS	PLASTIC TYPE	PLASTIC COLOR	REMARK	

678007125	SEE NOTE2(c)							
678007122	SEE NOTE2(b)	3.25	3.45	2.40+/-0.05				
678007121	SEE NOTE2(a)							
678007115	SEE NOTE2(c)				HIGH			
678007112	SEE NOTE2(b)	2.85	3.05	2.00+/-0.05	TEMPERATURE	BLACK	PURE	
678007111	SEE NOTE2(a)				THERMAL		TIN	
678007105	SEE NOTE2(c)				PLASTIC			
678007102	SEE NOTE2(b)	2.45	2.65	1.60+/-0.05				
678007101	SEE NOTE2(a)							
MATERIAL NUMBER	PLATING TYPE	DIM A	DIM B	P.C.B THICKNESS	PLASTIC TYPE	PLASTIC COLOR	REMARK	

A

A

OBSOLESCE PART EC NO: SH2006-0566 DRWN: BCHENZ6 2006/05/29 CHKD: GRATE MA 2006/05/29 APPR: JNCHEN 2006/05/30	QUALITY SYMBOLS	GENERAL TOLERANCES (UNLESS SPECIFIED)	DIMENSION STYLE	SCALE	DESIGN UNITS	THIRD ANGLE PROJECTION
	▽=0	mm INCH	MM ONLY	5:1	METRIC	
	▽=0	4 PLACES ± --- ± ---	DRAWN BY DATE	TITLE		
		3 PLACES ± --- ± ---	GRATE MA 2004/02/02	HIGH SPEED CONNECTOR		
	2 PLACES ± 0.15 ± ---	CHECKED BY DATE	1.27MM PITCH VERTICAL			
	1 PLACE ± 0.25 ± ---	YA JUN 2004/02/02	DIP SOLDER TAIL			
	ANGULAR ± 1/2°	APPROVED BY DATE	MOLEX INCORPORATED			
		SAM 2004/02/02	MOLEX INCORPORATED			
		MATERIAL NO.	DOCUMENT NO.	SHEET NO.		
		SEE CHART	SD-67800-007	2 OF 2		
		DRAFT WHERE APPLICABLE MUST REMAIN WITHIN DIMENSIONS				
		THIS DRAWING CONTAINS INFORMATION THAT IS PROPRIETARY TO MOLEX INCORPORATED AND SHOULD NOT BE USED WITHOUT WRITTEN PERMISSION				