



## LOW VOLTAGE CMOS OCTAL BUS BUFFER WITH 3 STATE OUTPUTS (NON INVERTED)

- HIGH SPEED:  
 $t_{PD}=4.5ns$  (TYP.) at  $V_{CC} = 3.3V$
- 5V TOLERANT INPUTS
- POWER-DOWN PROTECTION ON INPUTS
- INPUT VOLTAGE LEVEL:  
 $V_{IL} = 0.8V$ ,  $V_{IH} = 2V$  at  $V_{CC} = 3V$
- LOW POWER DISSIPATION:  
 $I_{CC} = 4 \mu A$  (MAX.) at  $T_A=25^\circ C$
- LOW NOISE:  
 $V_{OLP} = 0.5V$  (TYP.) at  $V_{CC} = 3.3V$
- SYMMETRICAL OUTPUT IMPEDANCE:  
 $|I_{OH}| = I_{OL} = 4 mA$  (MIN) at  $V_{CC} = 3V$
- BALANCED PROPAGATION DELAYS:  
 $t_{PLH} \approx t_{PHL}$
- OPERATING VOLTAGE RANGE:  
 $V_{CC}(OPR) = 2V$  to  $3.6V$  (1.2V Data Retention)
- PIN AND FUNCTION COMPATIBLE WITH 74 SERIES 244
- IMPROVED LATCH-UP IMMUNITY

### DESCRIPTION

The 74LVX244 is a low voltage CMOS OCTAL BUS BUFFER (3-STATE) fabricated with sub-micron silicon gate and double-layer metal wiring C<sup>2</sup>MOS technology. It is ideal for low power, battery operated and low noise 3.3V applications.



**Table 1: Order Codes**

PACKAGE	T & R
SOP	74LVX244MTR
TSSOP	74LVX244TTR

$\overline{G}$  output enable governs four BUS BUFFERS  
 Power down protection is provided on all inputs and 0 to 7V can be accepted on inputs with no regard to the supply voltage.  
 This device can be used to interface 5V to 3V. It combines high speed performance with the true CMOS low power consumption.  
 All inputs and outputs are equipped with protection circuits against static discharge, giving them 2KV ESD immunity and transient excess voltage.

**Figure 1: Pin Connection And IEC Logic Symbols**

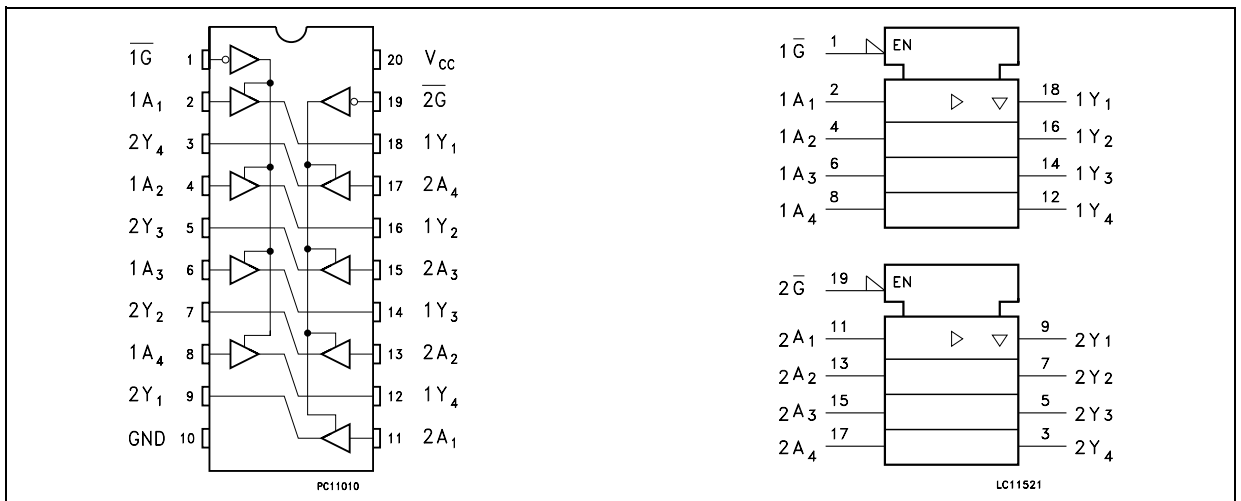

Figure 2: Input Equivalent Circuit

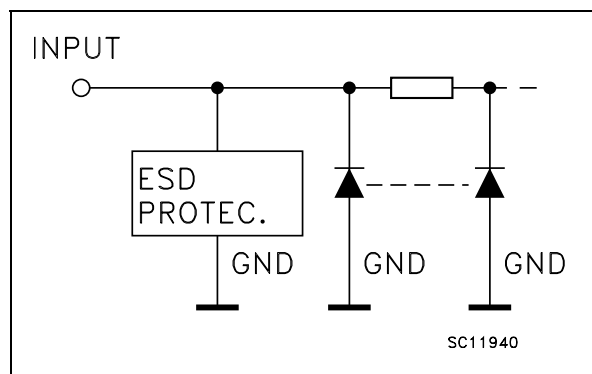

Table 2: Pin Description

PIN N°	SYMBOL	NAME AND FUNCTION
1	$\overline{1G}$	Output Enable Input
2, 4, 6, 8	1A1 to 1A4	Data Inputs
9, 7, 5, 3	2Y1 to 2Y4	Data Outputs
11, 13, 15, 17	2A1 to 2A4	Data Inputs
18, 16, 14, 12	1Y1 to 1Y4	Data Outputs
19	2G	Output Enable Input
10	GND	Ground (0V)
20	V <sub>CC</sub>	Positive Supply Voltage

Table 3: Truth Table

INPUTS		OUTPUT
$\overline{G}$	An	Yn
L	L	L
L	H	H
H	X	Z

X : Don't Care  
Z : High Impedance

Table 4: Absolute Maximum Ratings

Symbol	Parameter	Value	Unit
V <sub>CC</sub>	Supply Voltage	-0.5 to +7.0	V
V <sub>I</sub>	DC Input Voltage	-0.5 to +7.0	V
V <sub>O</sub>	DC Output Voltage	-0.5 to V <sub>CC</sub> + 0.5	V
I <sub>IK</sub>	DC Input Diode Current	- 20	mA
I <sub>OK</sub>	DC Output Diode Current	± 20	mA
I <sub>O</sub>	DC Output Current	± 25	mA
I <sub>CC</sub> or I <sub>GND</sub>	DC V <sub>CC</sub> or Ground Current	± 50	mA
T <sub>stg</sub>	Storage Temperature	-65 to +150	°C
T <sub>L</sub>	Lead Temperature (10 sec)	300	°C

Absolute Maximum Ratings are those values beyond which damage to the device may occur. Functional operation under these conditions is not implied

Table 5: Recommended Operating Conditions

Symbol	Parameter	Value	Unit
V <sub>CC</sub>	Supply Voltage (note 1)	2 to 3.6	V
V <sub>I</sub>	Input Voltage	0 to 5.5	V
V <sub>O</sub>	Output Voltage	0 to V <sub>CC</sub>	V
T <sub>op</sub>	Operating Temperature	-55 to 125	°C
dt/dv	Input Rise and Fall Time (note 2) (V <sub>CC</sub> = 3V)	0 to 100	ns/V

1) Truth Table guaranteed: 1.2V to 3.6V  
2) V<sub>IN</sub> from 0.8V to 2.0V

Table 6: DC Specifications

Symbol	Parameter	Test Condition		Value						Unit	
		V <sub>CC</sub> (V)		T <sub>A</sub> = 25°C			-40 to 85°C		-55 to 125°C		
				Min.	Typ.	Max.	Min.	Max.	Min.		Max.
V <sub>IH</sub>	High Level Input Voltage	2.0		1.5			1.5		1.5		V
		3.0		2.0			2.0		2.0		
		3.6		2.4			2.4		2.4		
V <sub>IL</sub>	Low Level Input Voltage	2.0				0.5		0.5		0.5	V
		3.0				0.8		0.8		0.8	
		3.6				0.8		0.8		0.8	
V <sub>OH</sub>	High Level Output Voltage	2.0	I <sub>O</sub> =-50 μA	1.9	2.0		1.9		1.9		V
		3.0	I <sub>O</sub> =-50 μA	2.9	3.0		2.9		2.9		
		3.0	I <sub>O</sub> =-4 mA	2.58			2.48		2.4		
V <sub>OL</sub>	Low Level Output Voltage	2.0	I <sub>O</sub> =50 μA		0.0	0.1		0.1		0.1	V
		3.0	I <sub>O</sub> =50 μA		0.0	0.1		0.1		0.1	
		3.0	I <sub>O</sub> =4 mA			0.36		0.44		0.55	
I <sub>OZ</sub>	High Impedance Output Leakage Current	3.6	V <sub>I</sub> = V <sub>IH</sub> or V <sub>IL</sub> V <sub>O</sub> = V <sub>CC</sub> or GND			±0.25		± 2.5		± 2.5	μA
I <sub>I</sub>	Input Leakage Current	3.6	V <sub>I</sub> = 5.5V or GND			± 0.1		± 1		± 1	μA
I <sub>CC</sub>	Quiescent Supply Current	3.6	V <sub>I</sub> = V <sub>CC</sub> or GND			4		40		40	μA

Table 7: Dynamic Switching Characteristics

Symbol	Parameter	Test Condition		Value						Unit	
		V <sub>CC</sub> (V)		T <sub>A</sub> = 25°C			-40 to 85°C		-55 to 125°C		
				Min.	Typ.	Max.	Min.	Max.	Min.		Max.
V <sub>OLP</sub>	Dynamic Low Voltage Quiet Output (note 1, 2)	3.3	C <sub>L</sub> = 50 pF		0.5	0.8					V
V <sub>OLV</sub>				-0.8	-0.5						
V <sub>IHD</sub>	Dynamic High Voltage Input (note 1, 3)	3.3		2.0							
V <sub>ILD</sub>	Dynamic Low Voltage Input (note 1, 3)	3.3				0.8					

1) Worst case package.

2) Max number of outputs defined as (n). Data inputs are driven 0V to 3.3V, (n-1) outputs switching and one output at GND.

3) Max number of data inputs (n) switching. (n-1) switching 0V to 3.3V. Inputs under test switching: 3.3V to threshold (V<sub>ILD</sub>), 0V to threshold (V<sub>IHD</sub>), f=1MHz.

Table 8: AC Electrical Characteristics (Input  $t_r = t_f = 3\text{ns}$ )

Symbol	Parameter	Test Condition		Value						Unit	
		$V_{CC}$ (V)	$C_L$ (pF)	$T_A = 25^\circ\text{C}$			$-40$ to $85^\circ\text{C}$		$-55$ to $125^\circ\text{C}$		
				Min.	Typ.	Max.	Min.	Max.	Min.		Max.
$t_{PLH}$ $t_{PHL}$	Propagation Delay Time	2.7	15		6.1	11.4	1.0	13.5	1.0	15.0	ns
		2.7	50		8.6	14.9	1.0	17.0	1.0	18.0	
		3.3 <sup>(*)</sup>	15		4.5	7.1	1.0	8.5	1.0	9.5	
		3.3 <sup>(*)</sup>	50		7.2	10.6	1.0	12.0	1.0	13.0	
$t_{PZL}$ $t_{PZH}$	Output Enable Time	2.7	15		7.1	13.8	1.0	16.5	1.0	17.5	ns
		2.7	50		9.6	17.3	1.0	20.0	1.0	21.0	
		3.3 <sup>(*)</sup>	15		5.5	8.8	1.0	10.5	1.0	12.	
		3.3 <sup>(*)</sup>	50		8.0	12.3	1.0	14.0	1.0	15.0	
$t_{PLZ}$ $t_{PHZ}$	Output Disable Time	2.7	50		11.6	16.0	1.0	19.0	1.0	20.5	ns
		3.3 <sup>(*)</sup>	50		9.7	11.4	1.0	13.0	1.0	14.5	
$t_{OSLH}$ $t_{OSHL}$	Output to Output Skew Time (note 1,2)	2.7	50		0.5	1.0		1.5		1.5	ns
		3.3 <sup>(*)</sup>	50		0.5	1.0		1.5		1.5	

1) Skew is defined as the absolute value of the difference between the actual propagation delay for any two outputs of the same device switching in the same direction, either HIGH or LOW

2) Parameter guaranteed by design

(\*) Voltage range is  $3.3\text{V} \pm 0.3\text{V}$

Table 9: Capacitive Characteristics

Symbol	Parameter	Test Condition		Value						Unit	
		$V_{CC}$ (V)		$T_A = 25^\circ\text{C}$			$-40$ to $85^\circ\text{C}$		$-55$ to $125^\circ\text{C}$		
				Min.	Typ.	Max.	Min.	Max.	Min.		Max.
$C_{IN}$	Input Capacitance	3.3			4	10		10		10	pF
$C_{OUT}$	Output Capacitance	3.3			6						pF
$C_{PD}$	Power Dissipation Capacitance (note 1)	3.3	$f_{IN} = 10\text{MHz}$		19						pF

1)  $C_{PD}$  is defined as the value of the IC's internal equivalent capacitance which is calculated from the operating current consumption without load. (Refer to Test Circuit). Average operating current can be obtained by the following equation.  $I_{CC(oper)} = C_{PD} \times V_{CC} \times f_{IN} + I_{CC}/8$  (per circuit)

Figure 3: Test Circuit

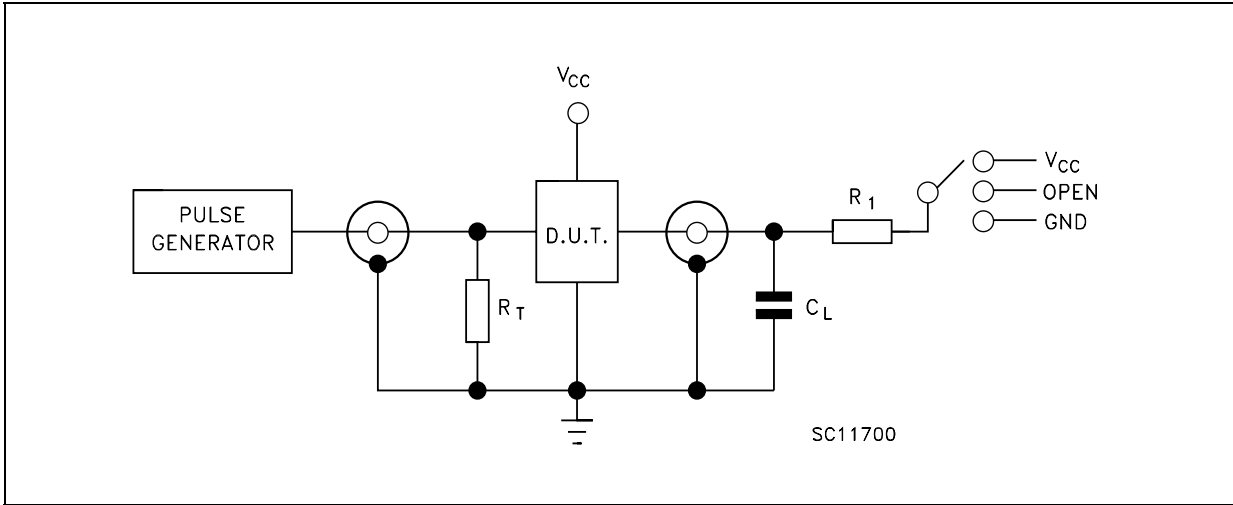

TEST	SWITCH
$t_{PLH}, t_{PHL}$	Open
$t_{PZL}, t_{PLZ}$	$V_{CC}$
$t_{PZH}, t_{PHZ}$	GND

$C_L = 15/50\text{pF}$  or equivalent (includes jig and probe capacitance)  
 $R_L = R_1 = 1\text{K}\Omega$  or equivalent  
 $R_T = Z_{OUT}$  of pulse generator (typically  $50\Omega$ )

Figure 4: Waveform - Propagation Delays ( $f=1\text{MHz}$ ; 50% duty cycle)

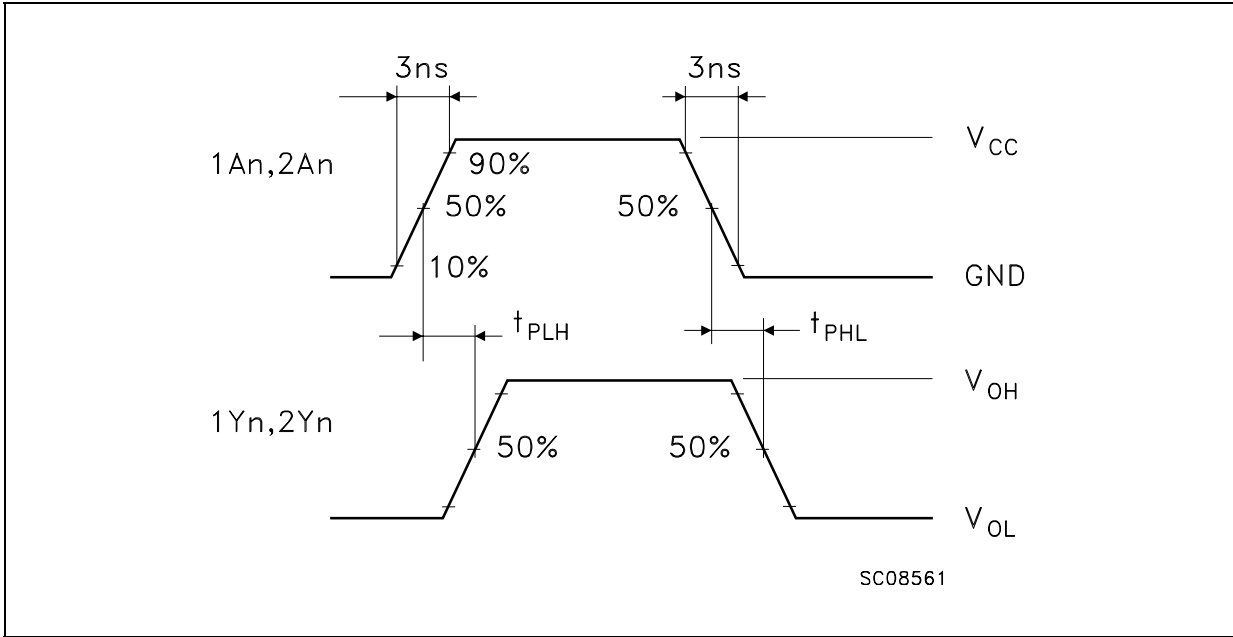
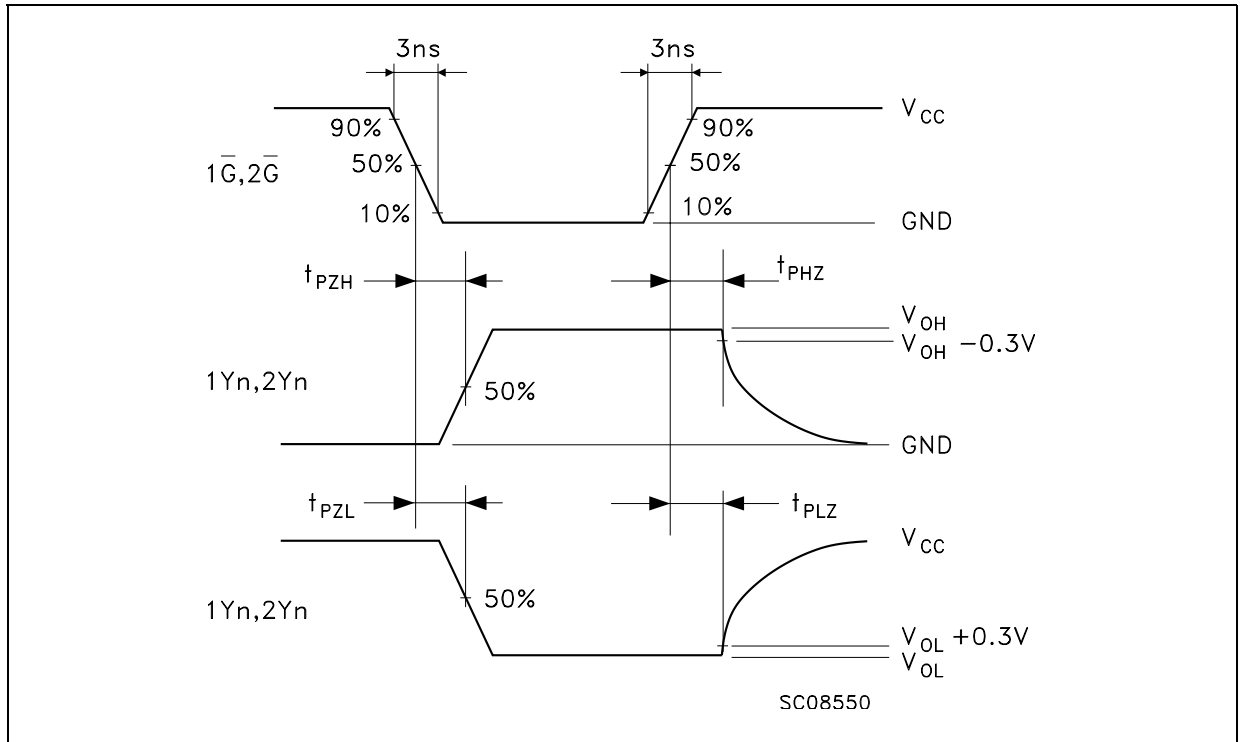
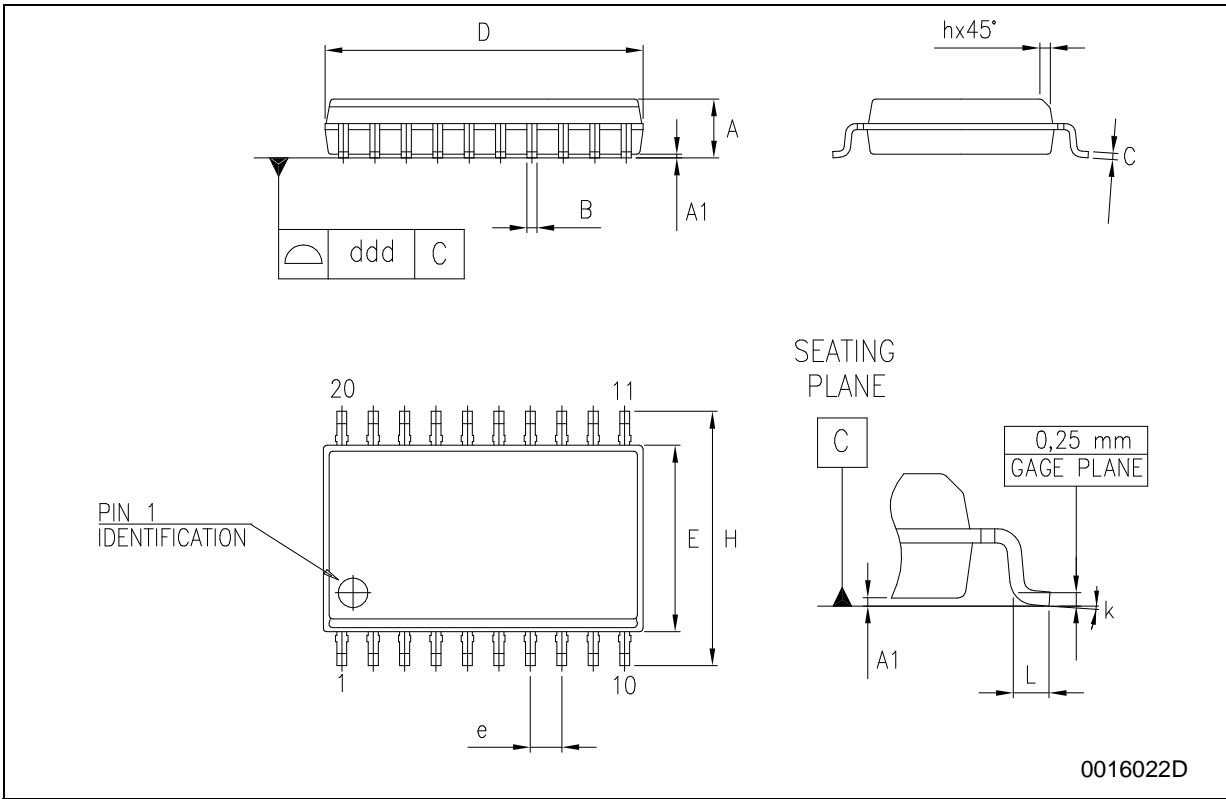

Figure 5: Waveform - Output Enable And Disable Time (f=1MHz; 50% duty cycle)



**SO-20 MECHANICAL DATA**

DIM.	mm.			inch		
	MIN.	TYP.	MAX.	MIN.	TYP.	MAX.
A	2.35		2.65	0.093		0.104
A1	0.1		0.30	0.004		0.012
B	0.33		0.51	0.013		0.020
C	0.23		0.32	0.009		0.013
D	12.60		13.00	0.496		0.512
E	7.4		7.6	0.291		0.299
e		1.27			0.050	
H	10.00		10.65	0.394		0.419
h	0.25		0.75	0.010		0.030
L	0.4		1.27	0.016		0.050
k	0°		8°	0°		8°
ddd			0.100			0.004



## TSSOP20 MECHANICAL DATA

DIM.	mm.			inch		
	MIN.	TYP	MAX.	MIN.	TYP.	MAX.
A			1.2			0.047
A1	0.05		0.15	0.002	0.004	0.006
A2	0.8	1	1.05	0.031	0.039	0.041
b	0.19		0.30	0.007		0.012
c	0.09		0.20	0.004		0.0079
D	6.4	6.5	6.6	0.252	0.256	0.260
E	6.2	6.4	6.6	0.244	0.252	0.260
E1	4.3	4.4	4.48	0.169	0.173	0.176
e		0.65 BSC			0.0256 BSC	
K	0°		8°	0°		8°
L	0.45	0.60	0.75	0.018	0.024	0.030

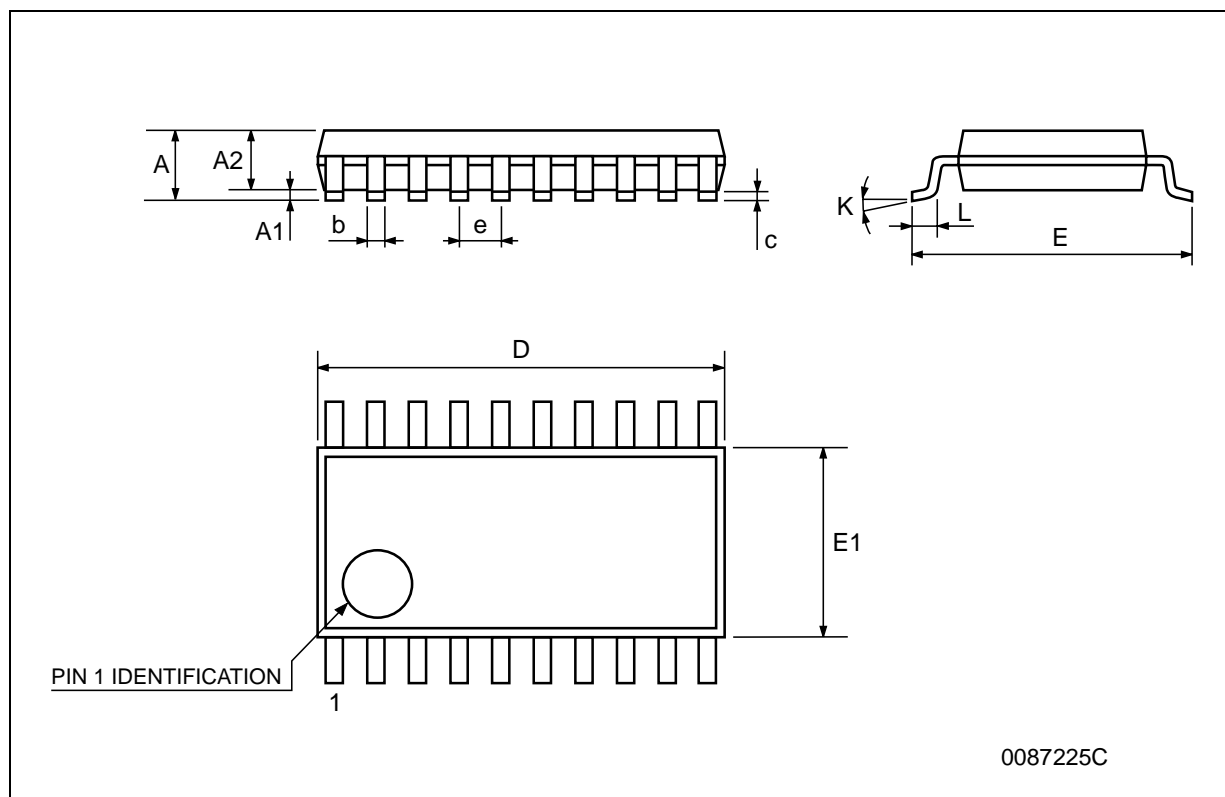



**Tape & Reel SO-20 MECHANICAL DATA**

DIM.	mm.			inch		
	MIN.	TYP	MAX.	MIN.	TYP.	MAX.
A			330			12.992
C	12.8		13.2	0.504		0.519
D	20.2			0.795		
N	60			2.362		
T			30.4			1.197
Ao	10.8		11	0.425		0.433
Bo	13.2		13.4	0.520		0.528
Ko	3.1		3.3	0.122		0.130
Po	3.9		4.1	0.153		0.161
P	11.9		12.1	0.468		0.476

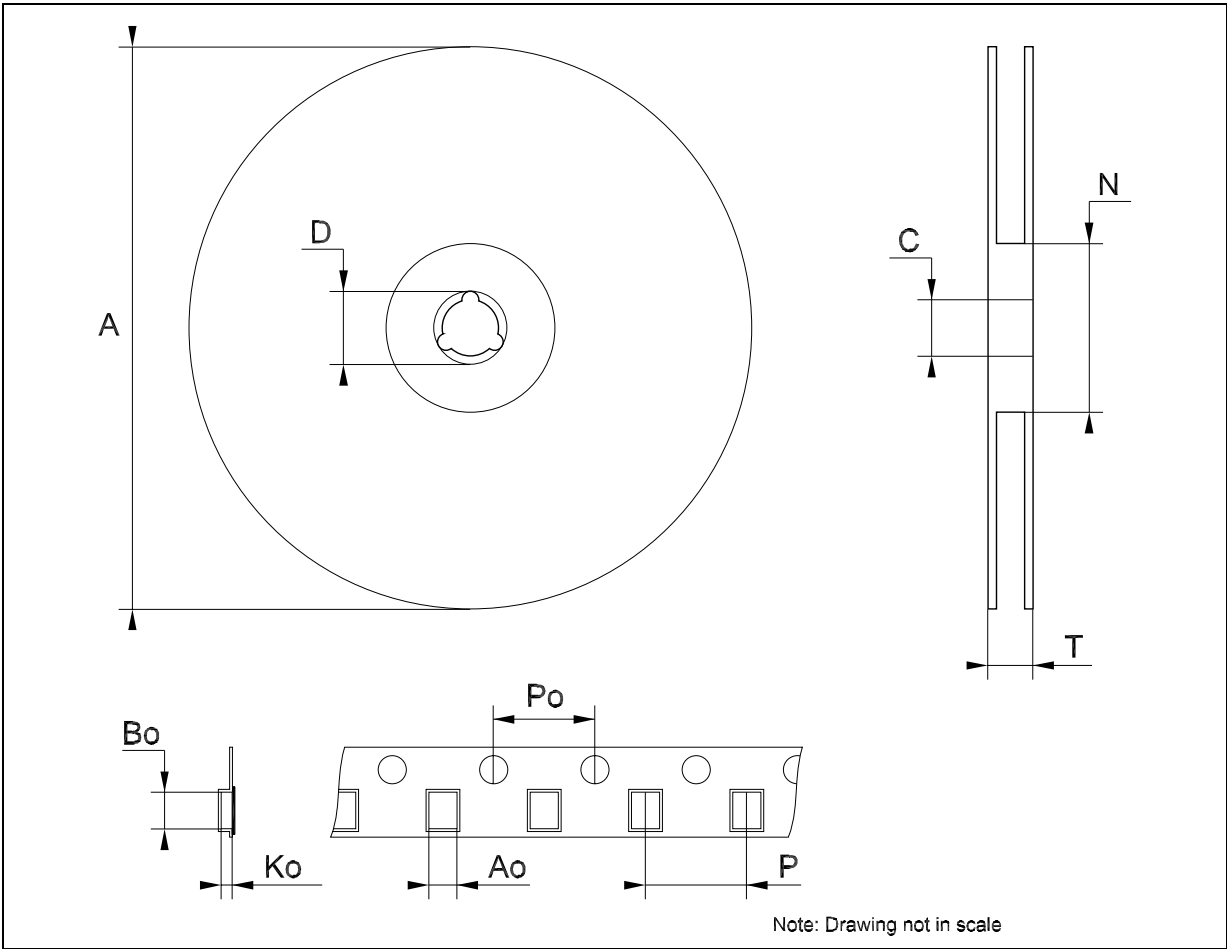

## Tape &amp; Reel TSSOP20 MECHANICAL DATA

DIM.	mm.			inch		
	MIN.	TYP	MAX.	MIN.	TYP.	MAX.
A			330			12.992
C	12.8		13.2	0.504		0.519
D	20.2			0.795		
N	60			2.362		
T			22.4			0.882
Ao	6.8		7	0.268		0.276
Bo	6.9		7.1	0.272		0.280
Ko	1.7		1.9	0.067		0.075
Po	3.9		4.1	0.153		0.161
P	11.9		12.1	0.468		0.476



**Table 10: Revision History**

Date	Revision	Description of Changes
27-Aug-2004	4	Ordering Codes Revision - pag. 1.

Information furnished is believed to be accurate and reliable. However, STMicroelectronics assumes no responsibility for the consequences of use of such information nor for any infringement of patents or other rights of third parties which may result from its use. No license is granted by implication or otherwise under any patent or patent rights of STMicroelectronics. Specifications mentioned in this publication are subject to change without notice. This publication supersedes and replaces all information previously supplied. STMicroelectronics products are not authorized for use as critical components in life support devices or systems without express written approval of STMicroelectronics.

The ST logo is a registered trademark of STMicroelectronics

All other names are the property of their respective owners

© 2004 STMicroelectronics - All Rights Reserved

STMicroelectronics group of companies

Australia - Belgium - Brazil - Canada - China - Czech Republic - Finland - France - Germany - Hong Kong - India - Israel - Italy - Japan - Malaysia - Malta - Morocco - Singapore - Spain - Sweden - Switzerland - United Kingdom - United States of America

[www.st.com](http://www.st.com)