

General Purpose NPN Epitaxial Planar Transistor

BTD1768BA3

Description

The BTD1768BA3 is designed for use in driver and output stages of AF amplifier and general purpose application.

Features

- Low collector saturation voltage
- High breakdown voltage, $V_{CE0}=80V$ (min.)
- High collector current, $I_{C(max)}=1A$ (DC)
- Pb-free package

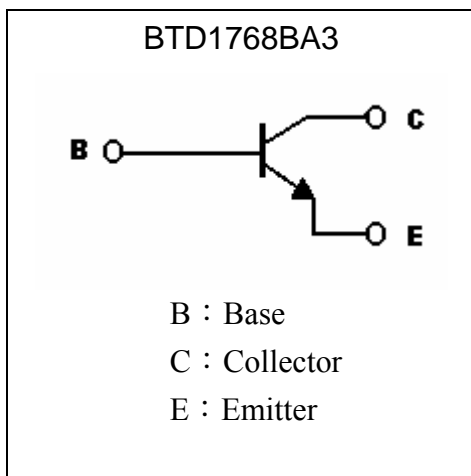
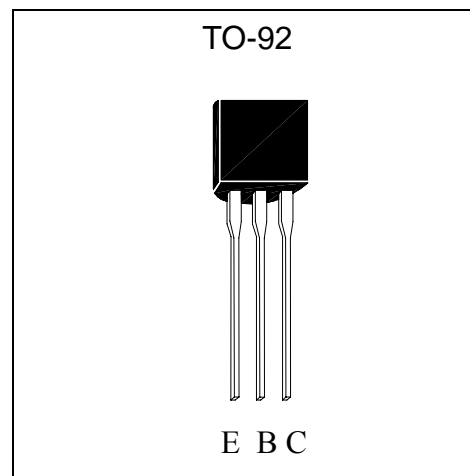
Symbol

Outline

Absolute Maximum Ratings ($T_a=25^{\circ}C$)

Parameter	Symbol	Limits	Unit
Collector-Base Voltage	V_{CB0}	100	V
Collector-Emitter Voltage	V_{CE0}	80	V
Emitter-Base Voltage	V_{EB0}	5	V
Collector Current (DC)	I_C	1	A
Collector Current (Pulse)	I_{CP}	2 (Note)	A
Power Dissipation	P_D	750	mW
Thermal Resistance, Junction to Ambient	$R_{\theta JA}$	167	$^{\circ}C/W$
Junction Temperature	T_j	150	$^{\circ}C$
Storage Temperature	T_{stg}	-55~+150	$^{\circ}C$

Note : Pulse test, $P_w \leq 10ms$, Duty $\leq 50\%$.



Characteristics (Ta=25°C)

Symbol	Min.	Typ.	Max.	Unit	Test Conditions
BV_{CBO}	100	-	-	V	$I_C=50\mu A$
BV_{CEO}	80	-	-	V	$I_C=1mA$
BV_{EBO}	5	-	-	V	$I_E=50\mu A$
I_{CBO}	-	-	1	μA	$V_{CB}=80V, I_E=0$
I_{EBO}	-	-	1	μA	$V_{EB}=4V, I_C=0$
$*V_{CE(SAT)}$	-	0.15	0.4	V	$I_C=500mA, I_B=20mA$
$*h_{FE}$	120	-	560	-	$V_{CE}=3V, I_C=100mA$
f_T	-	100	-	MHz	$V_{CE}=10V, I_C=50mA, f=100MHz$
Cob	-	20	-	pF	$V_{CB}=10V, I_E=0A, f=1MHz$

*Pulse Test: Pulse Width $\leq 380\mu s$, Duty Cycle $\leq 2\%$

Classification Of h_{FE}

Rank	Q	R	S
Range	120~270	180~390	270~560

Ordering Information

Device	Package	Shipping	Marking
BTD1768BA3	TO-92 (Pb-free)	1000 pcs / Bag, 10 Bags/Box	D1768



Characteristic Curves

Current Gain vs Collector Current

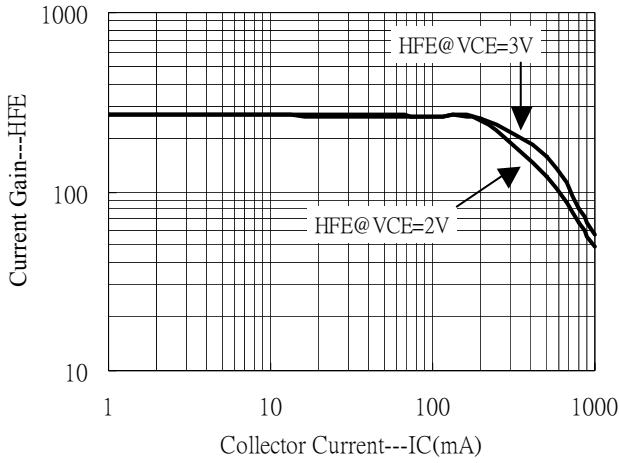

Saturation Voltage vs Collector Current

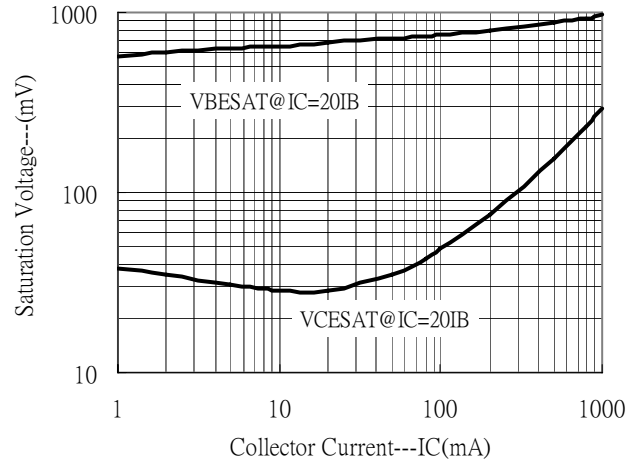

On Voltage vs Collector Current

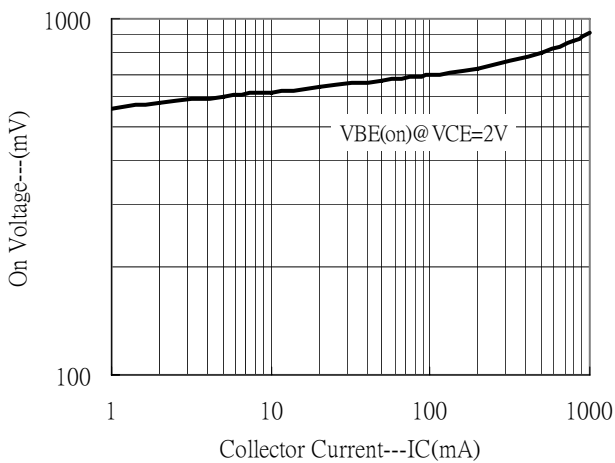

Power Derating Curve

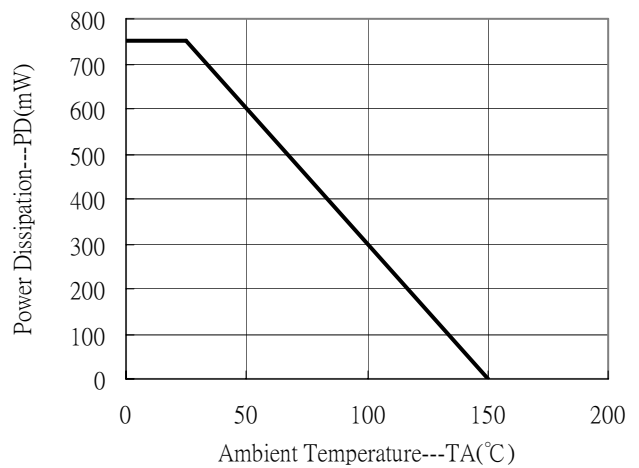

TO-92 Dimension

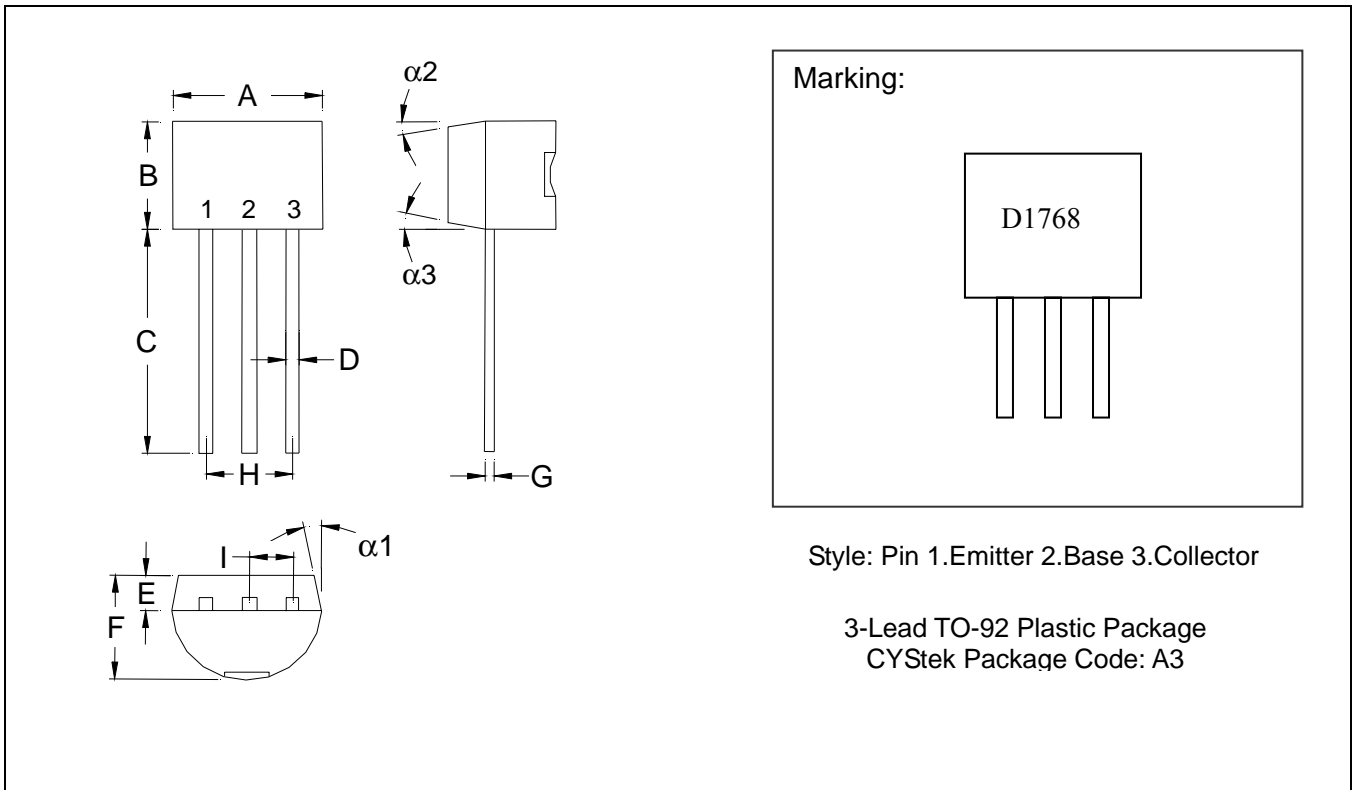

*: Typical

DIM	Inches		Millimeters		DIM	Inches		Millimeters	
	Min.	Max.	Min.	Max.		Min.	Max.	Min.	Max.
A	0.1704	0.1902	4.33	4.83	G	0.0142	0.0220	0.36	0.56
B	0.1704	0.1902	4.33	4.83	H	-	*0.1000	-	*2.54
C	0.5000	-	12.70	-	I	-	*0.0500	-	*1.27
D	0.0142	0.0220	0.36	0.56	$\alpha 1$	-	*5°	-	*5°
E	-	*0.0500	-	*1.27	$\alpha 2$	-	*2°	-	*2°
F	0.1323	0.1480	3.36	3.76	$\alpha 3$	-	*2°	-	*2°

Notes: 1. Controlling dimension: millimeters.
 2. Maximum lead thickness includes lead finish thickness, and minimum lead thickness is the minimum thickness of base material.
 3. If there is any question with packing specification or packing method, please contact your local CYStek sales office.

Material:

- Lead: 42 Alloy ; solder plating
- Mold Compound: Epoxy resin family, flammability solid burning class: UL94V-0

Important Notice:

- All rights are reserved. Reproduction in whole or in part is prohibited without the prior written approval of CYStek.
- CYStek reserves the right to make changes to its products without notice.
- CYStek **semiconductor products are not warranted to be suitable for use in Life-Support Applications, or systems.**
- CYStek assumes no liability for any consequence of customer product design, infringement of patents, or application assistance.