



PCA9546A

4-channel I²C-bus switch with reset

Rev. 05 — 2 July 2009

Product data sheet

1. General description

The PCA9546A is a quad bidirectional translating switch controlled via the I²C-bus. The SCL/SDA upstream pair fans out to four downstream pairs, or channels. Any individual SCx/SDx channel or combination of channels can be selected, determined by the contents of the programmable control register.

An active LOW reset input allows the PCA9546A to recover from a situation where one of the downstream I²C-buses is stuck in a LOW state. Pulling the RESET pin LOW resets the I²C-bus state machine and causes all the channels to be deselected as does the internal Power-On Reset (POR) function.

The pass gates of the switches are constructed such that the V_{DD} pin can be used to limit the maximum high voltage which will be passed by the PCA9546A. This allows the use of different bus voltages on each pair, so that 1.8 V or 2.5 V or 3.3 V parts can communicate with 5 V parts without any additional protection. External pull-up resistors pull the bus up to the desired voltage level for each channel. All I/O pins are 5 V tolerant.

2. Features

- 1-of-4 bidirectional translating switches
- I²C-bus interface logic; compatible with SMBus standards
- Active LOW reset input
- 3 address pins allowing up to 8 devices on the I²C-bus
- Channel selection via I²C-bus, in any combination
- Power-up with all switch channels deselected
- Low R_{on} switches
- Allows voltage level translation between 1.8 V, 2.5 V, 3.3 V and 5 V buses
- No glitch on power-up
- Supports hot insertion
- Low standby current
- Operating power supply voltage range of 2.3 V to 5.5 V
- 5 V tolerant Inputs
- 0 Hz to 400 kHz clock frequency
- ESD protection exceeds 2000 V HBM per JESD22-A114, 200 V MM per JESD22-A115, and 1000 V CDM per JESD22-C101
- Latch-up testing is done to JEDEC Standard JESD78 which exceeds 100 mA
- Three packages offered: SO16, TSSOP16, and HVQFN16

3. Ordering information

Table 1. Ordering information

Type number	Package		
	Name	Description	Version
PCA9546ABS	HVQFN16	plastic thermal enhanced very thin quad flat package; no leads; 16 terminals; body 4 × 4 × 0.85 mm	SOT629-1
PCA9546AD	SO16	plastic small outline package; 16 leads; body width 3.9 mm	SOT109-1
PCA9546APW	TSSOP16	plastic thin shrink small outline package; 16 leads; body width 4.4 mm	SOT403-1

3.1 Ordering options

Table 2. Ordering options

Type number	Topside mark	Temperature range
PCA9546ABS	546A	−40 °C to +85 °C
PCA9546AD	PCA9546AD	−40 °C to +85 °C
PCA9546APW	PA9546A	−40 °C to +85 °C

4. Block diagram

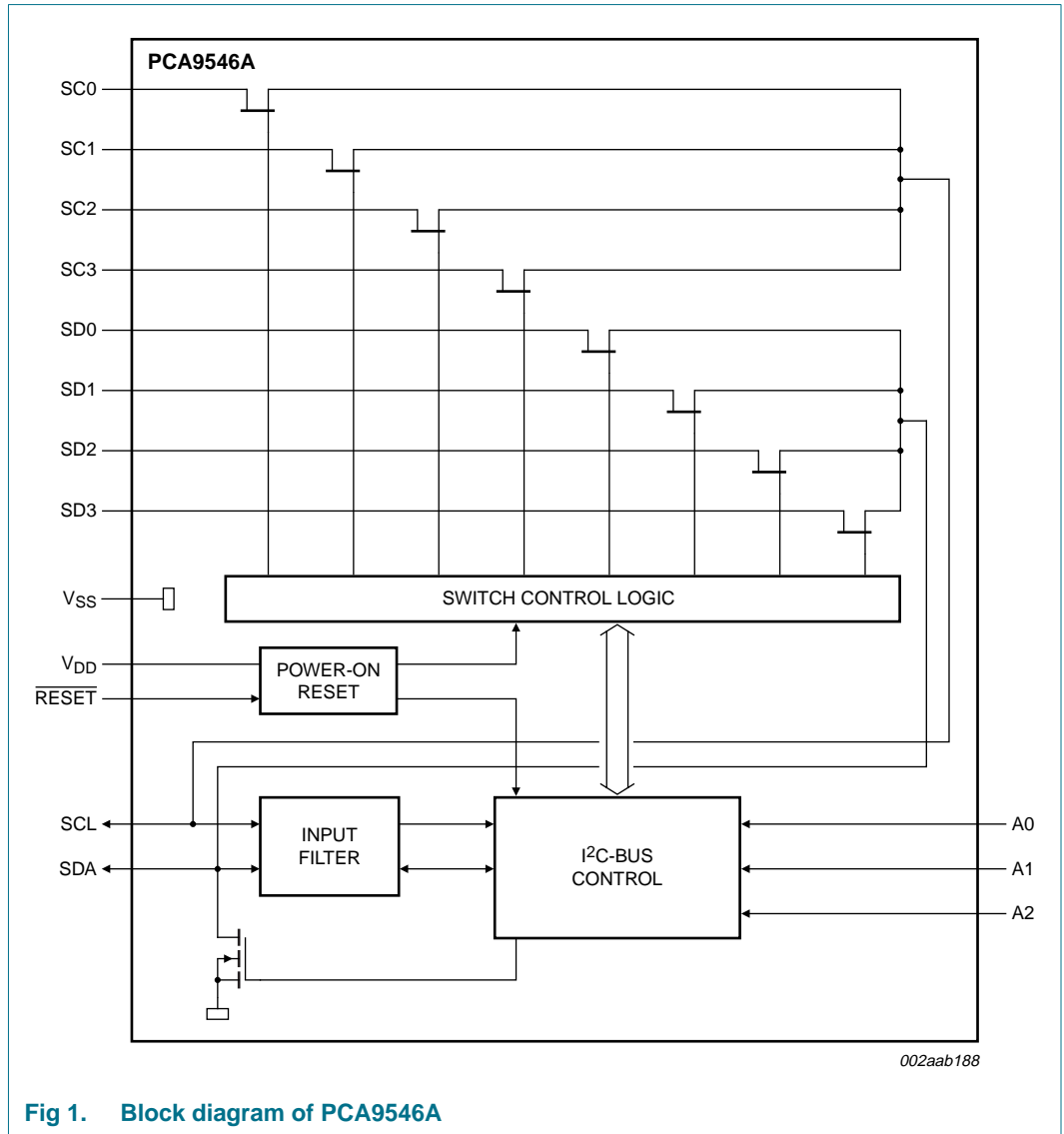

Fig 1. Block diagram of PCA9546A

5. Pinning information

5.1 Pinning

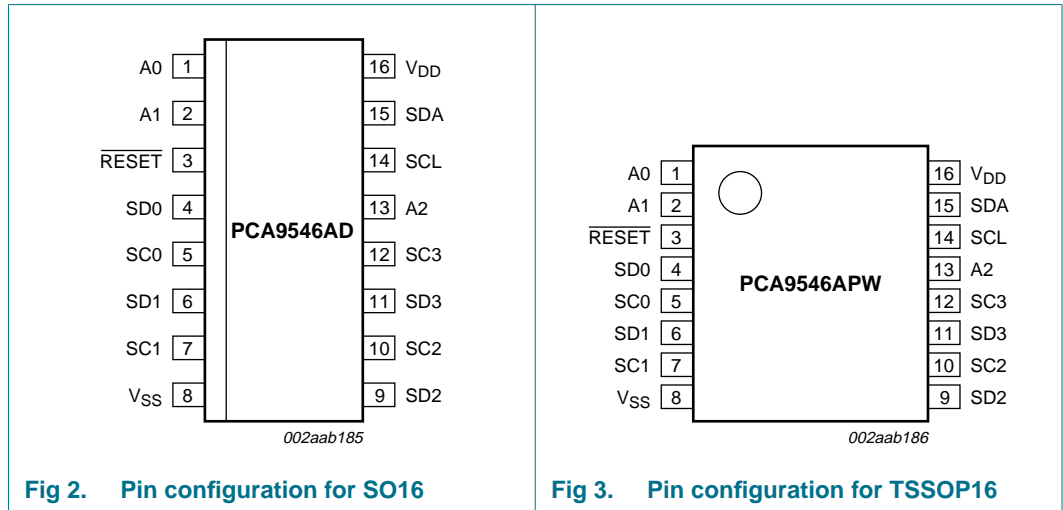

Fig 2. Pin configuration for SO16

Fig 3. Pin configuration for TSSOP16

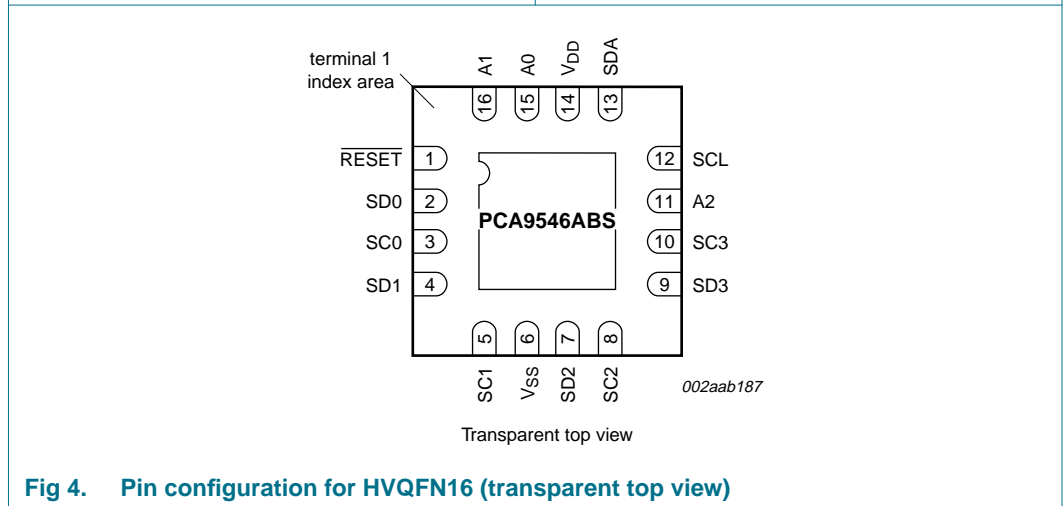

Fig 4. Pin configuration for HVQFN16 (transparent top view)

5.2 Pin description

Table 3. Pin description

Symbol	Pin		Description
	SO16, TSSOP16	HVQFN16	
A0	1	15	address input 0
A1	2	16	address input 1
RESET	3	1	active LOW reset input
SD0	4	2	serial data 0
SC0	5	3	serial clock 0
SD1	6	4	serial data 1
SC1	7	5	serial clock 1
V _{SS}	8	6 ^[1]	supply ground
SD2	9	7	serial data 2
SC2	10	8	serial clock 2
SD3	11	9	serial data 3
SC3	12	10	serial clock 3
A2	13	11	address input 2
SCL	14	12	serial clock line
SDA	15	13	serial data line
V _{DD}	16	14	supply voltage

[1] HVQFN16 package die supply ground is connected to both the V_{SS} pin and the exposed center pad. The V_{SS} pin must be connected to supply ground for proper device operation. For enhanced thermal, electrical, and board-level performance, the exposed pad needs to be soldered to the board using a corresponding thermal pad on the board, and for proper heat conduction through the board thermal vias need to be incorporated in the PCB in the thermal pad region.

6. Functional description

Refer to [Figure 1 “Block diagram of PCA9546A”](#).

6.1 Device address

Following a START condition, the bus master must output the address of the slave it is accessing. The address of the PCA9546A is shown in [Figure 5](#). To conserve power, no internal pull-up resistors are incorporated on the hardware selectable address pins and they must be pulled HIGH or LOW.

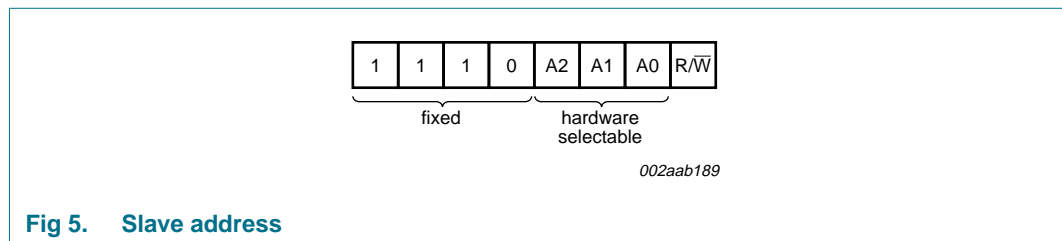

Fig 5. Slave address

The last bit of the slave address defines the operation to be performed. When set to logic 1 a read is selected, while a logic 0 selects a write operation.

6.2 Control register

Following the successful acknowledgement of the slave address, the bus master will send a byte to the PCA9546A, which will be stored in the control register. If multiple bytes are received by the PCA9546A, it will save the last byte received. This register can be written and read via the I²C-bus.

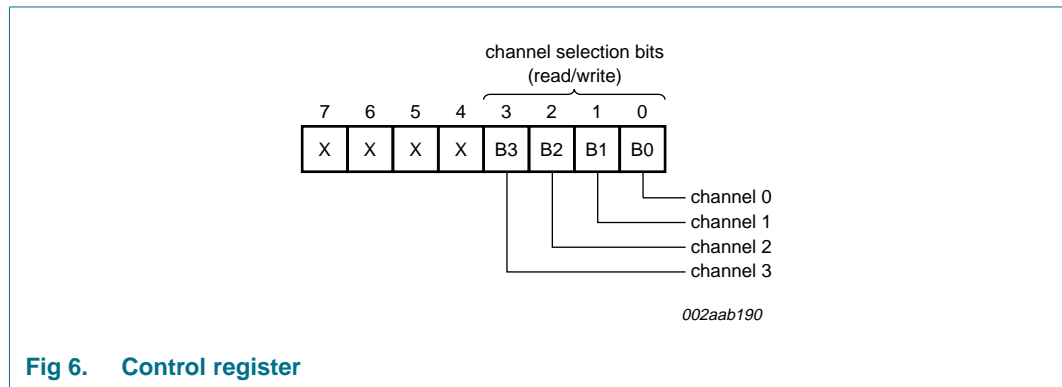

Fig 6. Control register

6.2.1 Control register definition

One or several SCx/SDx downstream pair, or channel, is selected by the contents of the control register. This register is written after the PCA9546A has been addressed. The 4 LSBs of the control byte are used to determine which channel is to be selected. When a channel is selected, the channel will become active after a STOP condition has been placed on the I²C-bus. This ensures that all SCx/SDx lines will be in a HIGH state when the channel is made active, so that no false conditions are generated at the time of connection.

Table 4. Control register: Write—channel selection; Read—channel status

D7	D6	D5	D4	B3	B2	B1	B0	Command
X	X	X	X	X	X	X	0	channel 0 disabled
							1	channel 0 enabled
X	X	X	X	X	X	0	X	channel 1 disabled
						1		channel 1 enabled
X	X	X	X	X	0	X	X	channel 2 disabled
					1			channel 2 enabled
X	X	X	X	0	X	X	X	channel 3 disabled
				1				channel 3 enabled
0	0	0	0	0	0	0	0	no channel selected; power-up/reset default state

Remark: Several channels can be enabled at the same time. Example: B3 = 0, B2 = 1, B1 = 1, B0 = 0, means that channel 0 and channel 3 are disabled and channel 1 and channel 2 are enabled. Care should be taken not to exceed the maximum bus capacitance.

6.3 RESET input

The $\overline{\text{RESET}}$ input is an active LOW signal which may be used to recover from a bus fault condition. By asserting this signal LOW for a minimum of $t_{w(\text{rst})L}$, the PCA9546A will reset its registers and I²C-bus state machine and will deselect all channels. The $\overline{\text{RESET}}$ input must be connected to V_{DD} through a pull-up resistor.

6.4 Power-on reset

When power is applied to V_{DD} , an internal Power-On Reset (POR) holds the PCA9546A in a reset condition until V_{DD} has reached V_{POR} . At this point, the reset condition is released and the PCA9546A registers and I²C-bus state machine are initialized to their default states (all zeroes) causing all the channels to be deselected. Thereafter, V_{DD} must be lowered below 0.2 V to reset the device.

6.5 Voltage translation

The pass gate transistors of the PCA9546A are constructed such that the V_{DD} voltage can be used to limit the maximum voltage that will be passed from one I²C-bus to another.

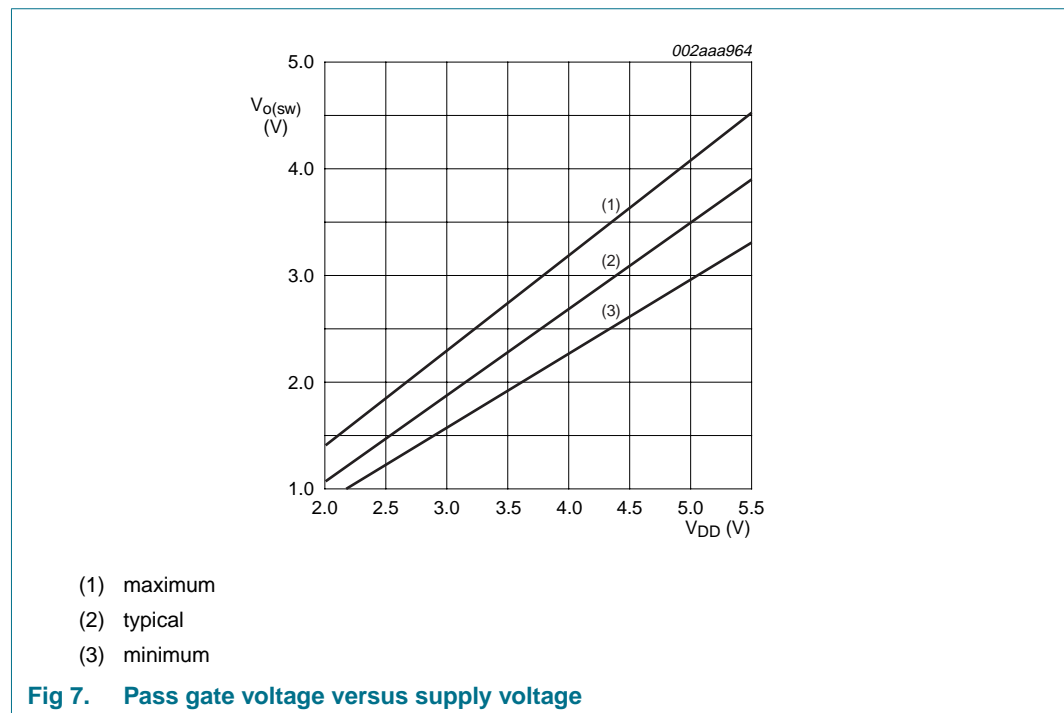

Figure 7 shows the voltage characteristics of the pass gate transistors (note that the graph was generated using the data specified in Section 10 “Static characteristics” of this data sheet). In order for the PCA9546A to act as a voltage translator, the $V_{O(\text{sw})}$ voltage should be equal to, or lower than the lowest bus voltage. For example, if the main bus was running at 5 V, and the downstream buses were 3.3 V and 2.7 V, then $V_{O(\text{sw})}$ should be equal to or below 2.7 V to effectively clamp the downstream bus voltages. Looking at Figure 7, we see that $V_{O(\text{sw})(\text{max})}$ will be at 2.7 V when the PCA9546A supply voltage is 3.5 V or lower, so the PCA9546A supply voltage could be set to 3.3 V. Pull-up resistors can then be used to bring the bus voltages to their appropriate levels (see Figure 14).

More Information can be found in Application Note AN262: PCA954X family of I²C/SMBus multiplexers and switches.

7. Characteristics of the I²C-bus

The I²C-bus is for 2-way, 2-line communication between different ICs or modules. The two lines are a serial data line (SDA) and a serial clock line (SCL). Both lines must be connected to a positive supply via a pull-up resistor when connected to the output stages of a device. Data transfer may be initiated only when the bus is not busy.

7.1 Bit transfer

One data bit is transferred during each clock pulse. The data on the SDA line must remain stable during the HIGH period of the clock pulse as changes in the data line at this time will be interpreted as control signals (see [Figure 8](#)).

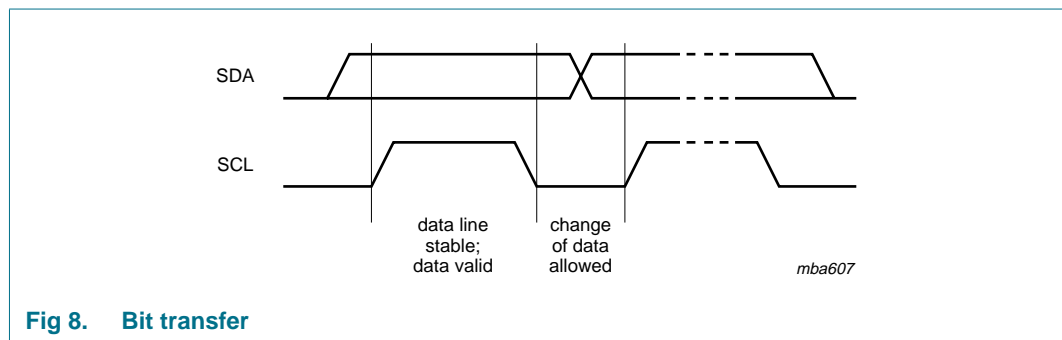

Fig 8. Bit transfer

7.2 START and STOP conditions

Both data and clock lines remain HIGH when the bus is not busy. A HIGH-to-LOW transition of the data line while the clock is HIGH is defined as the START condition (S). A LOW-to-HIGH transition of the data line while the clock is HIGH is defined as the STOP condition (P) (see [Figure 9](#)).

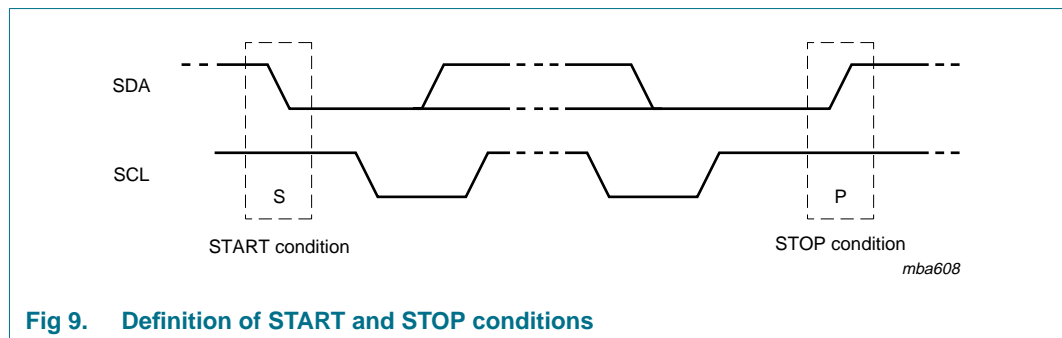

Fig 9. Definition of START and STOP conditions

7.3 System configuration

A device generating a message is a 'transmitter', a device receiving is the 'receiver'. The device that controls the message is the 'master' and the devices which are controlled by the master are the 'slaves' (see [Figure 10](#)).

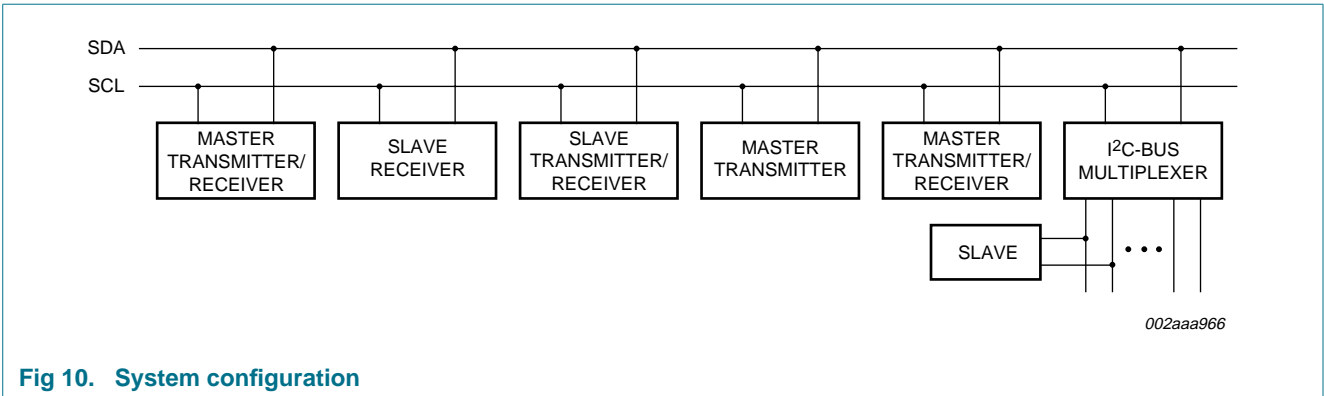

Fig 10. System configuration

7.4 Acknowledge

The number of data bytes transferred between the START and the STOP conditions from transmitter to receiver is not limited. Each byte of eight bits is followed by one acknowledge bit. The acknowledge bit is a HIGH level put on the bus by the transmitter, whereas the master generates an extra acknowledge related clock pulse.

A slave receiver which is addressed must generate an acknowledge after the reception of each byte. Also, a master must generate an acknowledge after the reception of each byte that has been clocked out of the slave transmitter. The device that acknowledges has to pull down the SDA line during the acknowledge clock pulse so that the SDA line is stable LOW during the HIGH period of the acknowledge related clock pulse; set-up and hold times must be taken into account.

A master receiver must signal an end of data to the transmitter by not generating an acknowledge on the last byte that has been clocked out of the slave. In this event, the transmitter must leave the data line HIGH to enable the master to generate a STOP condition.

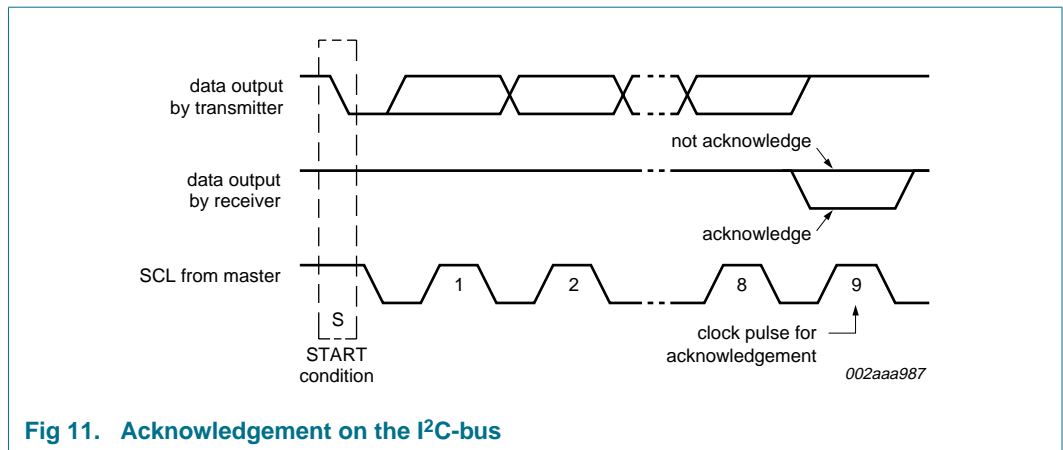

Fig 11. Acknowledgement on the I²C-bus

7.5 Bus transactions

Data is transmitted to the PCA9546A control register using the Write mode as shown in [Figure 12](#).

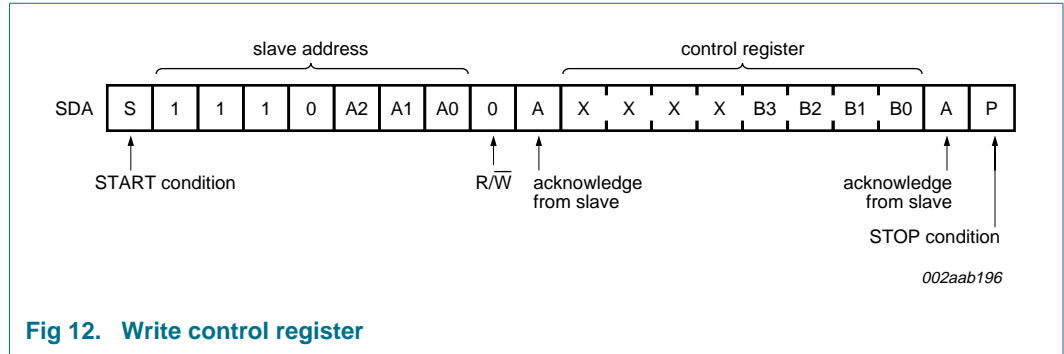

Fig 12. Write control register

Data is read from PCA9546A using the Read mode as shown in [Figure 13](#).

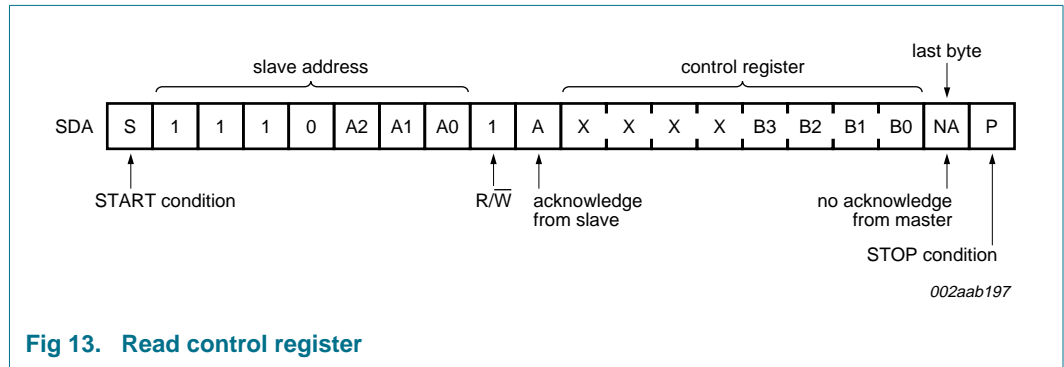

Fig 13. Read control register

8. Application design-in information

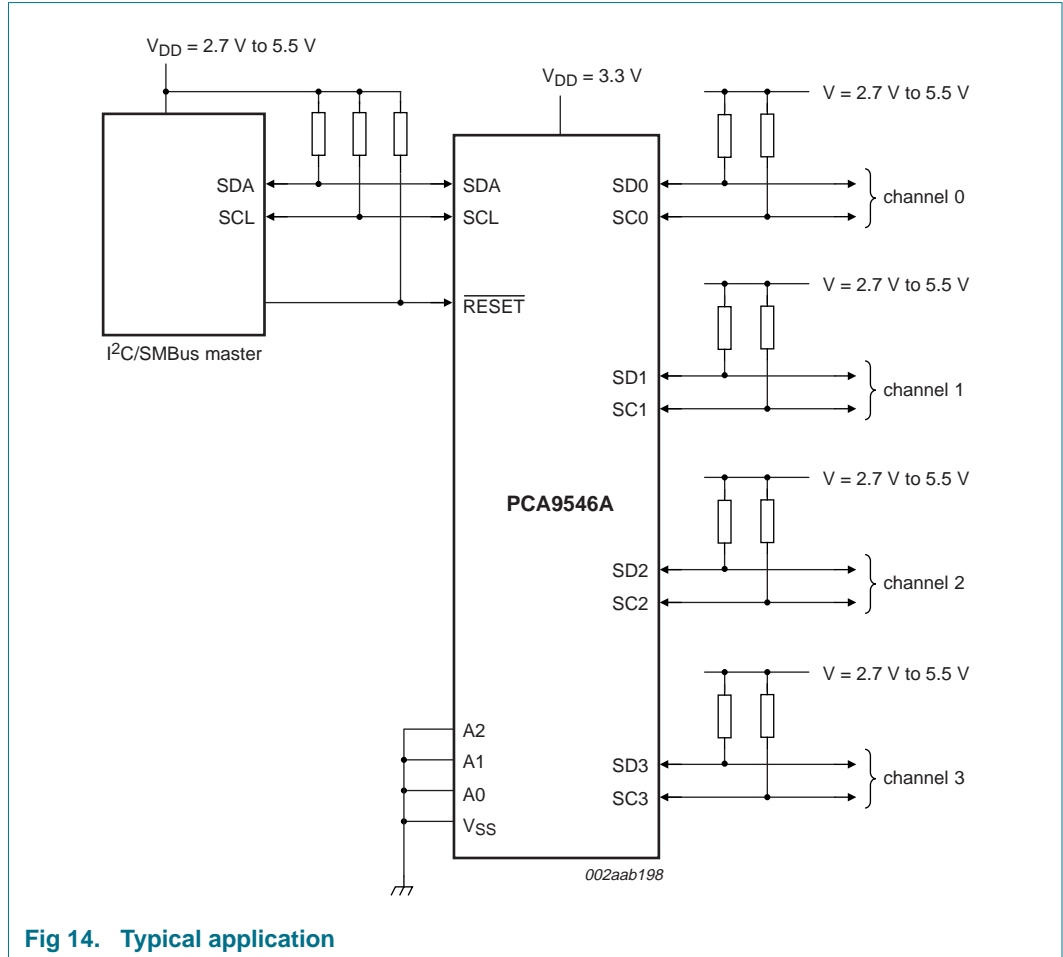

Fig 14. Typical application

9. Limiting values

Table 5. Limiting values

In accordance with the Absolute Maximum Rating System (IEC 60134).
Voltages are referenced to V_{SS} (ground = 0 V)^[1].

Symbol	Parameter	Conditions	Min	Max	Unit
V_{DD}	supply voltage		-0.5	+7.0	V
V_I	input voltage		-0.5	+7.0	V
I_I	input current		-	±20	mA
I_O	output current		-	±25	mA
I_{DD}	supply current		-	±100	mA
I_{SS}	ground supply current		-	±100	mA
P_{tot}	total power dissipation		-	400	mW
T_{stg}	storage temperature		-60	+150	°C
T_{amb}	ambient temperature	operating	-40	+85	°C

- [1] The performance capability of a high-performance integrated circuit in conjunction with its thermal environment can create junction temperatures which are detrimental to reliability. The maximum junction temperature of this integrated circuit should not exceed 125 °C.

10. Static characteristics

Table 6. Static characteristics at V_{DD} = 2.3 V to 3.6 V

V_{SS} = 0 V; T_{amb} = -40 °C to +85 °C; unless otherwise specified. See [Table 7 on page 14](#) for V_{DD} = 4.5 V to 5.5 V.^[1]

Symbol	Parameter	Conditions	Min	Typ	Max	Unit
Supply						
V _{DD}	supply voltage		2.3	-	3.6	V
I _{DD}	supply current	operating mode; V _{DD} = 3.6 V; no load; V _I = V _{DD} or V _{SS} ; f _{SCL} = 100 kHz	-	16	50	μA
I _{stb}	standby current	standby mode; V _{DD} = 3.6 V; no load; V _I = V _{DD} or V _{SS}	-	0.1	1	μA
V _{POR}	power-on reset voltage	no load; V _I = V _{DD} or V _{SS}	[2]	1.6	2.1	V
Input SCL; input/output SDA						
V _{IL}	LOW-level input voltage		-0.5	-	+0.3V _{DD}	V
V _{IH}	HIGH-level input voltage		0.7V _{DD}	-	6	V
I _{OL}	LOW-level output current	V _{OL} = 0.4 V	3	-	-	mA
		V _{OL} = 0.6 V	6	-	-	mA
I _L	leakage current	V _I = V _{DD} or V _{SS}	-1	-	+1	μA
C _i	input capacitance	V _I = V _{SS}	-	12	13	pF
Select inputs A0 to A2, RESET						
V _{IL}	LOW-level input voltage		-0.5	-	+0.3V _{DD}	V
V _{IH}	HIGH-level input voltage		0.7V _{DD}	-	V _{DD} + 0.5	V
I _{LI}	input leakage current	pin at V _{DD} or V _{SS}	-1	-	+1	μA
C _i	input capacitance	V _I = V _{SS}	-	1.6	3	pF
Pass gate						
R _{on}	ON-state resistance	V _{DD} = 3.6 V; V _O = 0.4 V; I _O = 15 mA	5	11	30	Ω
		V _{DD} = 2.3 V to 2.7 V; V _O = 0.4 V; I _O = 10 mA	7	16	55	Ω
V _{o(sw)}	switch output voltage	V _{i(sw)} = V _{DD} = 3.3 V; I _{o(sw)} = -100 μA	-	1.9	-	V
		V _{i(sw)} = V _{DD} = 3.0 V to 3.6 V; I _{o(sw)} = -100 μA	1.6	-	2.8	V
		V _{i(sw)} = V _{DD} = 2.5 V; I _{o(sw)} = -100 μA	-	1.5	-	V
		V _{i(sw)} = V _{DD} = 2.3 V to 2.7 V; I _{o(sw)} = -100 μA	1.1	-	2.0	V
I _L	leakage current	V _I = V _{DD} or V _{SS}	-1	-	+1	μA
C _{io}	input/output capacitance	V _I = V _{SS}	-	3	5	pF

[1] For operation between published voltage ranges, refer to the worst-case parameter in both ranges.

[2] V_{DD} must be lowered to 0.2 V in order to reset part.

Table 7. Static characteristics at V_{DD} = 4.5 V to 5.5 V

V_{SS} = 0 V; T_{amb} = -40 °C to +85 °C; unless otherwise specified. See [Table 6 on page 13](#) for V_{DD} = 2.3 V to 3.6 V^[1]

Symbol	Parameter	Conditions	Min	Typ	Max	Unit
Supply						
V _{DD}	supply voltage		4.5	-	5.5	V
I _{DD}	supply current	operating mode; V _{DD} = 5.5 V; no load; V _I = V _{DD} or V _{SS} ; f _{SCL} = 100 kHz	-	65	100	μA
I _{stb}	standby current	standby mode; V _{DD} = 5.5 V; no load; V _I = V _{DD} or V _{SS}	-	0.3	1	μA
V _{POR}	power-on reset voltage	no load; V _I = V _{DD} or V _{SS}	[2] -	1.7	2.1	V
Input SCL; input/output SDA						
V _{IL}	LOW-level input voltage		-0.5	-	+0.3V _{DD}	V
V _{IH}	HIGH-level input voltage		0.7V _{DD}	-	6	V
I _{OL}	LOW-level output current	V _{OL} = 0.4 V	3	-	-	mA
		V _{OL} = 0.6 V	6	-	-	mA
I _{IL}	LOW-level input current	V _I = V _{SS}	-1	-	+1	μA
I _{IH}	HIGH-level input current	V _I = V _{DD}	-1	-	+1	μA
C _i	input capacitance	V _I = V _{SS}	-	12	13	pF
Select inputs A0 to A2, RESET						
V _{IL}	LOW-level input voltage		-0.5	-	+0.3V _{DD}	V
V _{IH}	HIGH-level input voltage		0.7V _{DD}	-	V _{DD} + 0.5	V
I _{LI}	input leakage current	pin at V _{DD} or V _{SS}	-1	-	+1	μA
C _i	input capacitance	V _I = V _{SS}	-	2	3	pF
Pass gate						
R _{on}	ON-state resistance	V _{DD} = 4.5 V to 5.5 V; V _O = 0.4 V; I _O = 15 mA	4	9	24	Ω
V _{O(sw)}	switch output voltage	V _{i(sw)} = V _{DD} = 5.0 V; I _{o(sw)} = -100 μA	-	3.6	-	V
		V _{i(sw)} = V _{DD} = 4.5 V to 5.5 V; I _{o(sw)} = -100 μA	2.6	-	4.5	V
I _L	leakage current	V _I = V _{DD} or V _{SS}	-1	-	+1	μA
C _{io}	input/output capacitance	V _I = V _{SS}	-	3	5	pF

[1] For operation between published voltage ranges, refer to the worst-case parameter in both ranges.

[2] V_{DD} must be lowered to 0.2 V in order to reset part.

11. Dynamic characteristics

Table 8. Dynamic characteristics

Symbol	Parameter	Conditions	Standard-mode I ² C-bus		Fast-mode I ² C-bus		Unit	
			Min	Max	Min	Max		
t _{PD}	propagation delay	from SDA to SDx, or SCL to SCx	-	0.3 ^[1]	-	0.3 ^[1]	ns	
f _{SCL}	SCL clock frequency		0	100	0	400	kHz	
t _{BUF}	bus free time between a STOP and START condition		4.7	-	1.3	-	μs	
t _{HD;STA}	hold time (repeated) START condition	^[2]	4.0	-	0.6	-	μs	
t _{LOW}	LOW period of the SCL clock		4.7	-	1.3	-	μs	
t _{HIGH}	HIGH period of the SCL clock		4.0	-	0.6	-	μs	
t _{SU;STA}	set-up time for a repeated START condition		4.7	-	0.6	-	μs	
t _{SU;STO}	set-up time for STOP condition		4.0	-	0.6	-	μs	
t _{HD;DAT}	data hold time		0 ^[3]	3.45	0 ^[3]	0.9	μs	
t _{SU;DAT}	data set-up time		250	-	100	-	ns	
t _r	rise time of both SDA and SCL signals		-	1000	20 + 0.1C _b ^[4]	300	ns	
t _f	fall time of both SDA and SCL signals		-	300	20 + 0.1C _b ^[4]	300	ns	
C _b	capacitive load for each bus line		-	400	-	400	pF	
t _{SP}	pulse width of spikes that must be suppressed by the input filter		-	50	-	50	ns	
t _{V D;DAT}	data valid time	HIGH-to-LOW	^[5]	-	1	-	1	μs
		LOW-to-HIGH	^[5]	-	0.6	-	0.6	μs
t _{V D;ACK}	data valid acknowledge time		-	1	-	1	μs	
RESET								
t _{w(rst)L}	LOW-level reset time		4	-	4	-	ns	
t _{rst}	reset time	SDA clear	500	-	500	-	ns	
t _{REC;STA}	recovery time to START condition		0	-	0	-	ns	

[1] Pass gate propagation delay is calculated from the 20 Ω typical R_{on} and the 15 pF load capacitance.

[2] After this period, the first clock pulse is generated.

[3] A device must internally provide a hold time of at least 300 ns for the SDA signal (referred to the V_{IH(min)} of the SCL signal) in order to bridge the undefined region of the falling edge of SCL.

[4] C_b = total capacitance of one bus line in pF.

[5] Measurements taken with 1 kΩ pull-up resistor and 50 pF load.

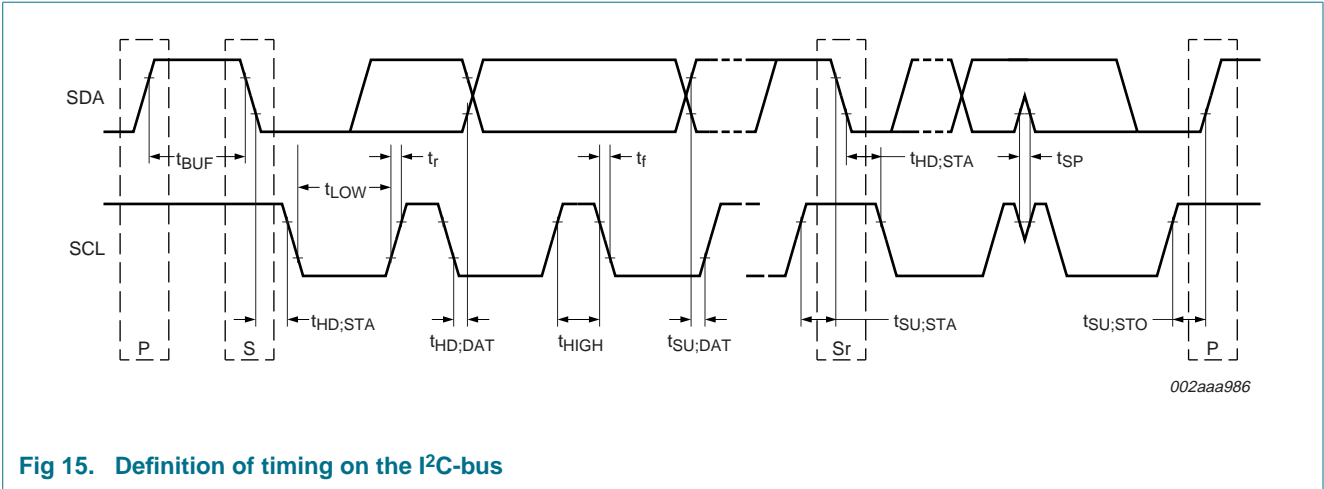

Fig 15. Definition of timing on the I²C-bus

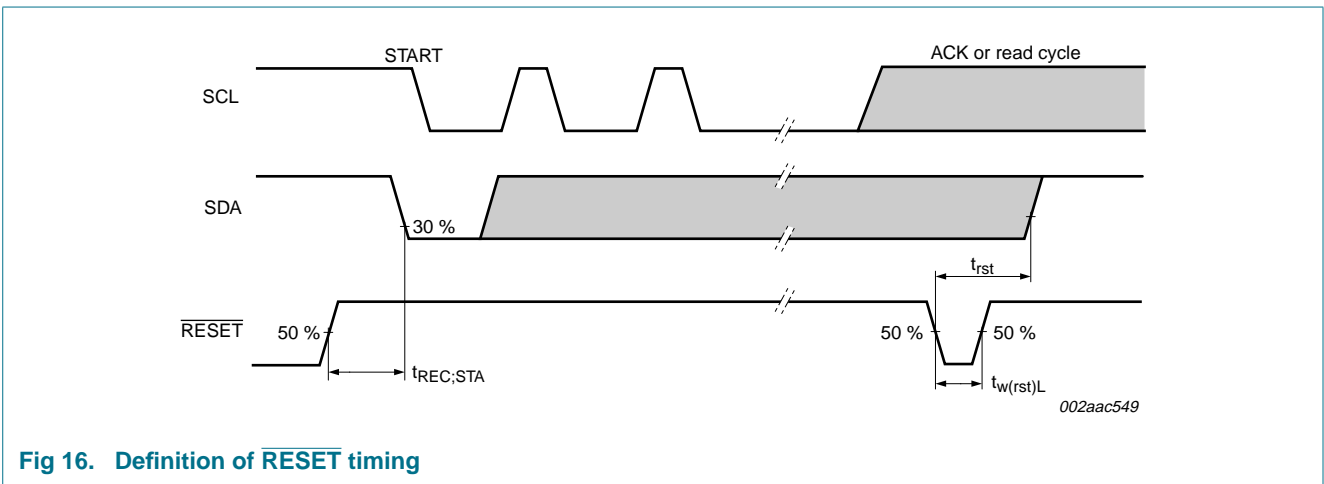

Fig 16. Definition of RESET timing

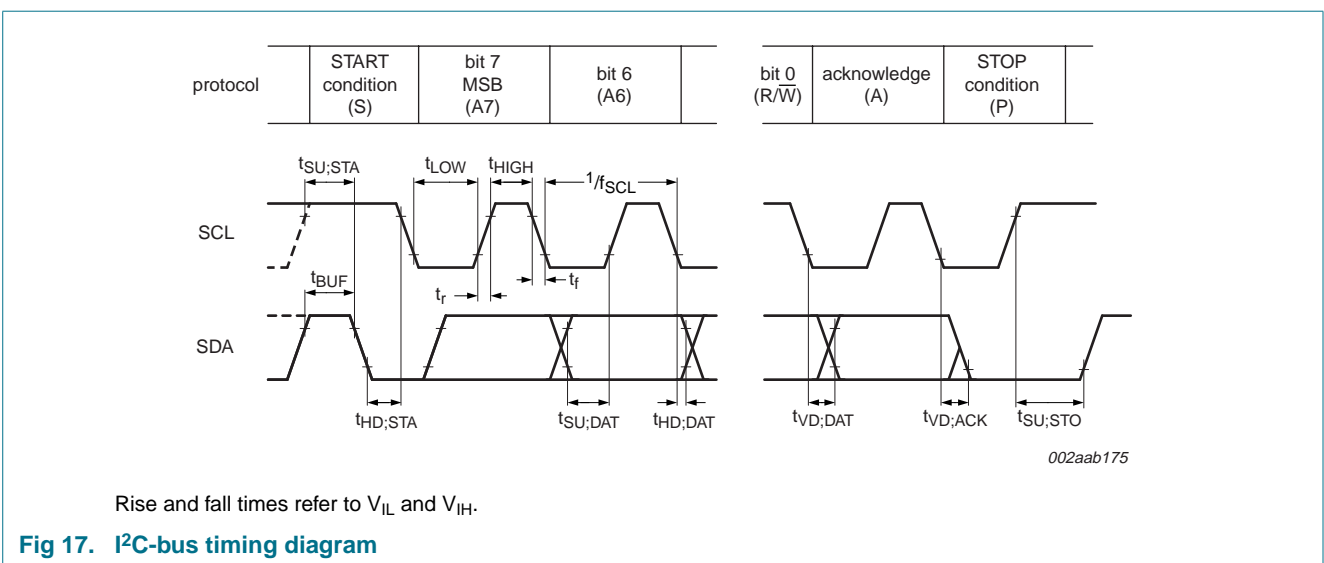

Fig 17. I²C-bus timing diagram

12. Package outline

SO16: plastic small outline package; 16 leads; body width 3.9 mm

SOT109-1

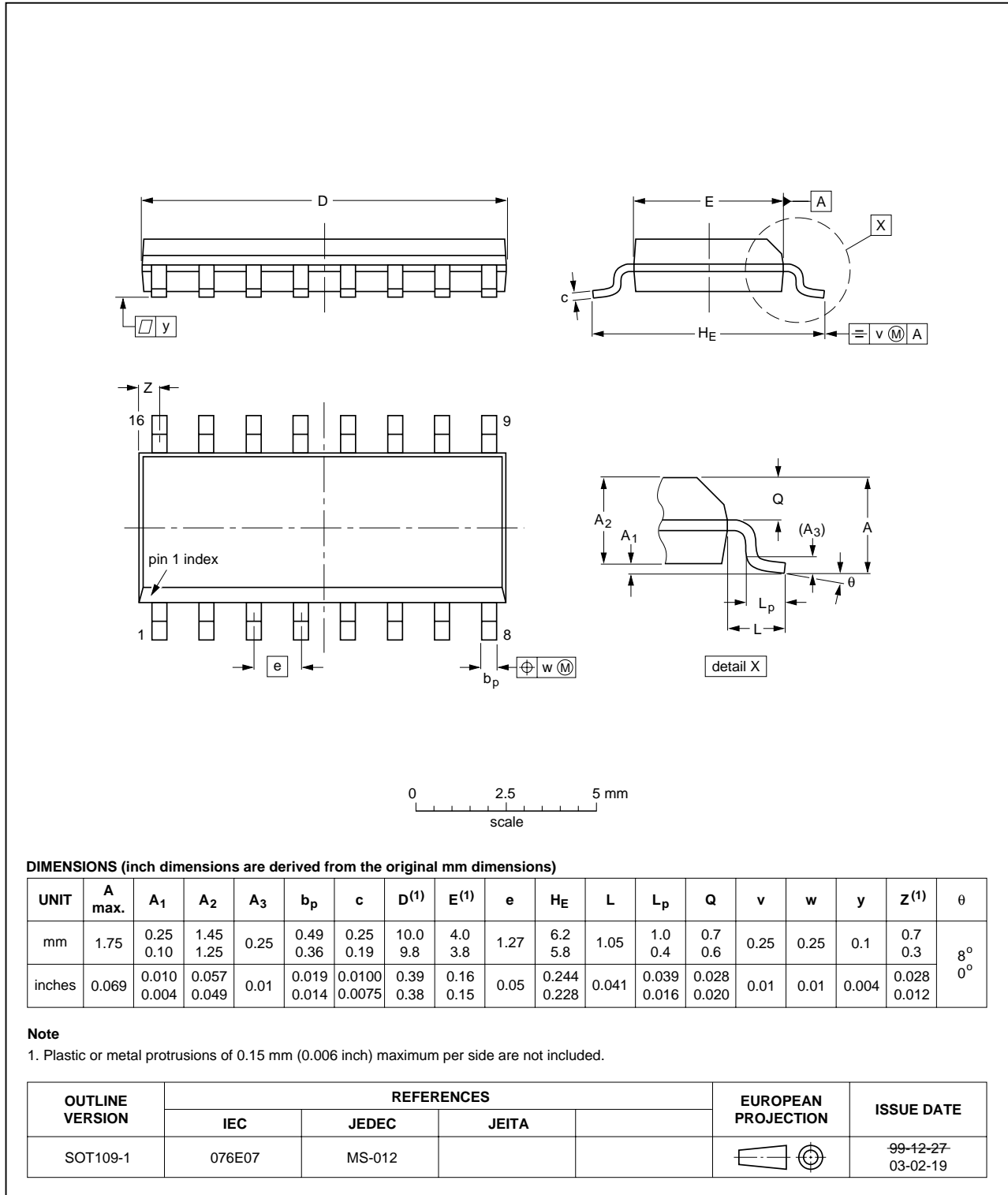

Fig 18. Package outline SOT109-1 (SO16)

TSSOP16: plastic thin shrink small outline package; 16 leads; body width 4.4 mm

SOT403-1

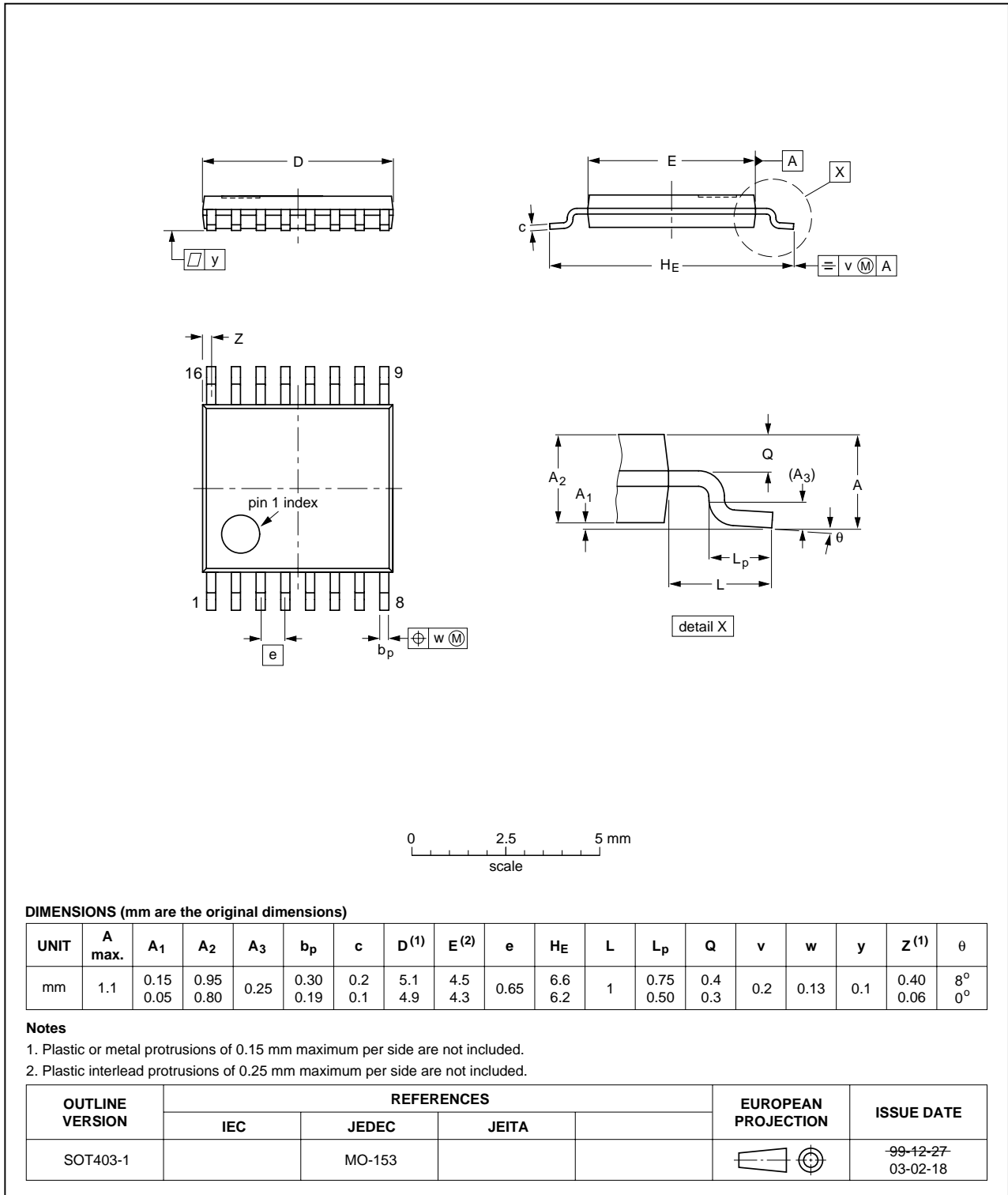

Fig 19. Package outline SOT403-1 (TSSOP16)

HVQFN16: plastic thermal enhanced very thin quad flat package; no leads; 16 terminals; body 4 x 4 x 0.85 mm

SOT629-1

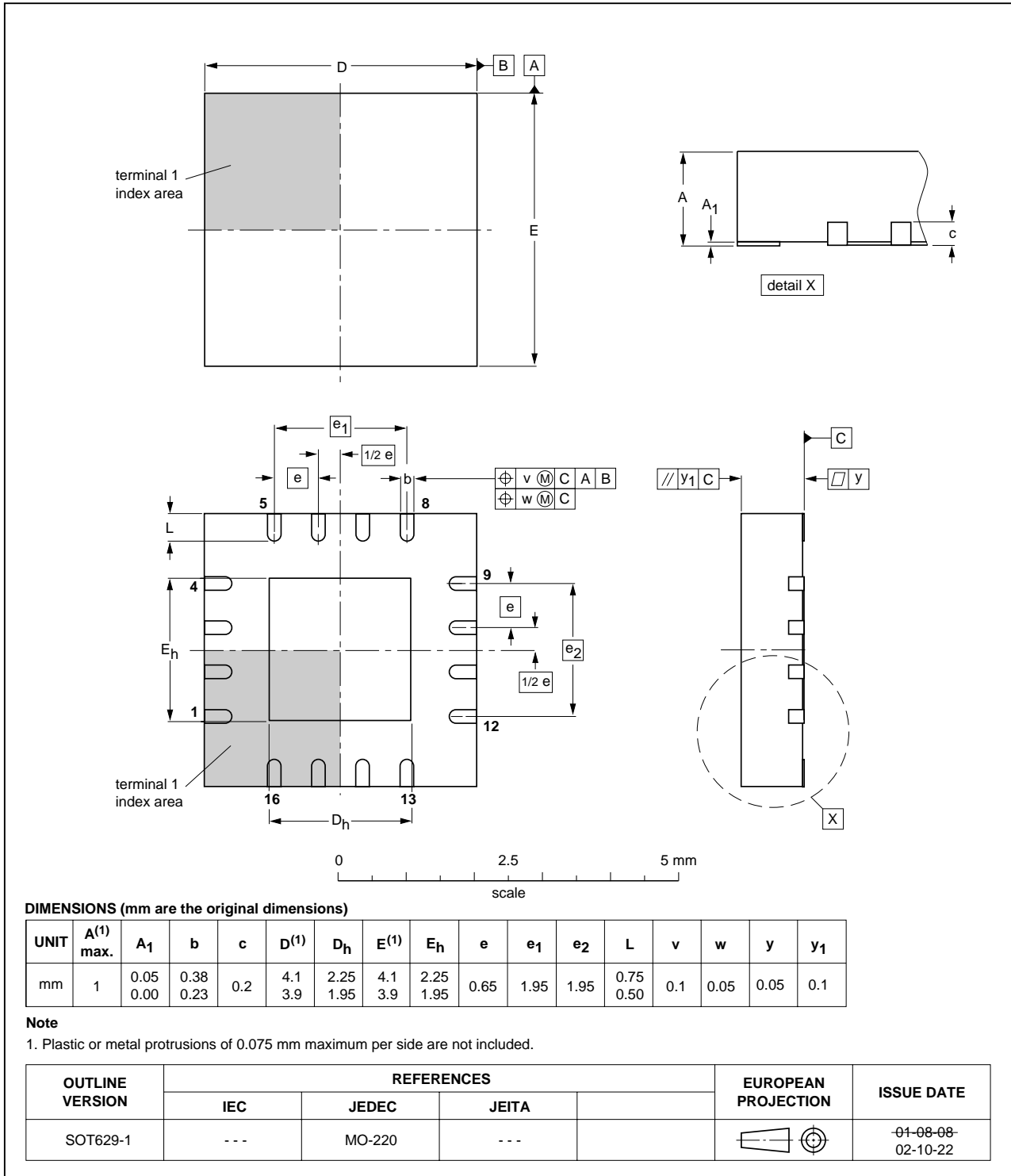

Fig 20. Package outline SOT629-1 (HVQFN16)

13. Soldering of SMD packages

This text provides a very brief insight into a complex technology. A more in-depth account of soldering ICs can be found in Application Note *AN10365 "Surface mount reflow soldering description"*.

13.1 Introduction to soldering

Soldering is one of the most common methods through which packages are attached to Printed Circuit Boards (PCBs), to form electrical circuits. The soldered joint provides both the mechanical and the electrical connection. There is no single soldering method that is ideal for all IC packages. Wave soldering is often preferred when through-hole and Surface Mount Devices (SMDs) are mixed on one printed wiring board; however, it is not suitable for fine pitch SMDs. Reflow soldering is ideal for the small pitches and high densities that come with increased miniaturization.

13.2 Wave and reflow soldering

Wave soldering is a joining technology in which the joints are made by solder coming from a standing wave of liquid solder. The wave soldering process is suitable for the following:

- Through-hole components
- Leaded or leadless SMDs, which are glued to the surface of the printed circuit board

Not all SMDs can be wave soldered. Packages with solder balls, and some leadless packages which have solder lands underneath the body, cannot be wave soldered. Also, leaded SMDs with leads having a pitch smaller than ~0.6 mm cannot be wave soldered, due to an increased probability of bridging.

The reflow soldering process involves applying solder paste to a board, followed by component placement and exposure to a temperature profile. Leaded packages, packages with solder balls, and leadless packages are all reflow solderable.

Key characteristics in both wave and reflow soldering are:

- Board specifications, including the board finish, solder masks and vias
- Package footprints, including solder thieves and orientation
- The moisture sensitivity level of the packages
- Package placement
- Inspection and repair
- Lead-free soldering versus SnPb soldering

13.3 Wave soldering

Key characteristics in wave soldering are:

- Process issues, such as application of adhesive and flux, clinching of leads, board transport, the solder wave parameters, and the time during which components are exposed to the wave
- Solder bath specifications, including temperature and impurities

13.4 Reflow soldering

Key characteristics in reflow soldering are:

- Lead-free versus SnPb soldering; note that a lead-free reflow process usually leads to higher minimum peak temperatures (see [Figure 21](#)) than a SnPb process, thus reducing the process window
- Solder paste printing issues including smearing, release, and adjusting the process window for a mix of large and small components on one board
- Reflow temperature profile; this profile includes preheat, reflow (in which the board is heated to the peak temperature) and cooling down. It is imperative that the peak temperature is high enough for the solder to make reliable solder joints (a solder paste characteristic). In addition, the peak temperature must be low enough that the packages and/or boards are not damaged. The peak temperature of the package depends on package thickness and volume and is classified in accordance with [Table 9](#) and [10](#)

Table 9. SnPb eutectic process (from J-STD-020C)

Package thickness (mm)	Package reflow temperature (°C)	
	Volume (mm ³)	
	< 350	≥ 350
< 2.5	235	220
≥ 2.5	220	220

Table 10. Lead-free process (from J-STD-020C)

Package thickness (mm)	Package reflow temperature (°C)		
	Volume (mm ³)		
	< 350	350 to 2000	> 2000
< 1.6	260	260	260
1.6 to 2.5	260	250	245
> 2.5	250	245	245

Moisture sensitivity precautions, as indicated on the packing, must be respected at all times.

Studies have shown that small packages reach higher temperatures during reflow soldering, see [Figure 21](#).

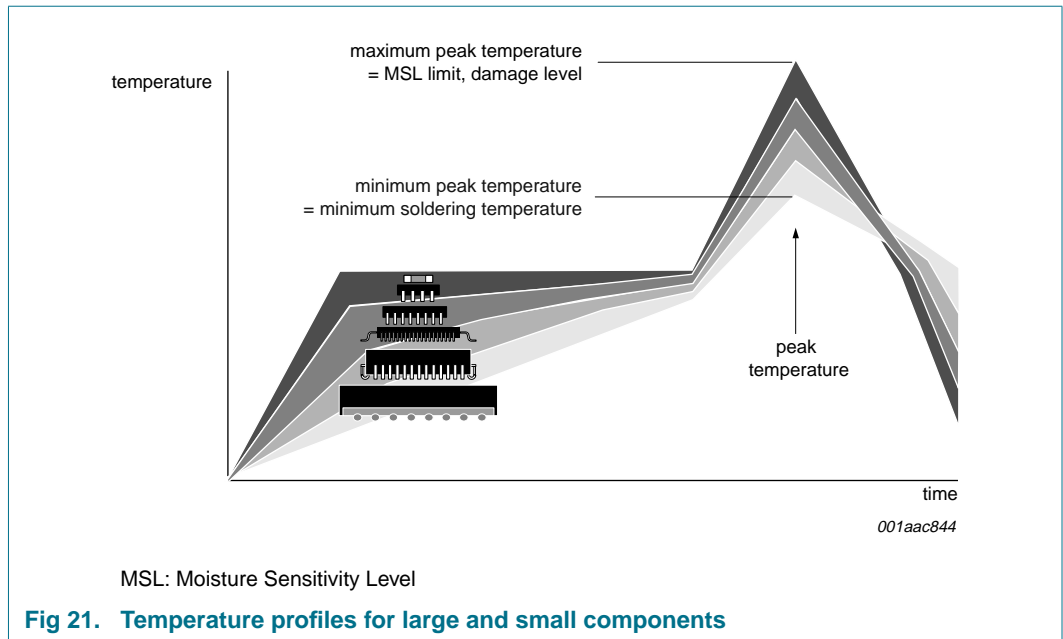

For further information on temperature profiles, refer to Application Note AN10365 “Surface mount reflow soldering description”.

14. Abbreviations

Table 11. Abbreviations

Acronym	Description
CDM	Charged-Device Model
ESD	ElectroStatic Discharge
HBM	Human Body Model
IC	Integrated Circuit
I ² C-bus	Inter-Integrated Circuit bus
LSB	Least Significant Bit
MM	Machine Model
MSB	Most Significant Bit
PCB	Printed-Circuit Board
SMBus	System Management Bus

15. Revision history

Table 12. Revision history

Document ID	Release date	Data sheet status	Change notice	Supersedes
PCA9546A_5	20090702	Product data sheet	-	PCA9546A_4
Modifications:		<ul style="list-style-type: none"> • The format of this data sheet has been redesigned to comply with the new identity guidelines of NXP Semiconductors. • Legal texts have been adapted to the new company name where appropriate. • Table 7 “Static characteristics at V_{DD} = 4.5 V to 5.5 V”, sub-section “Input SCL; input/output SDA”: <ul style="list-style-type: none"> – changed I_{IL} Min value from “1 μA” to “-1 μA” – changed I_{IL} Max value from “1 μA” to “+1 μA” – changed I_{IH} Min value from “1 μA” to “-1 μA” – changed I_{IH} Max value from “1 μA” to “+1 μA” • Table 8 “Dynamic characteristics”: <ul style="list-style-type: none"> – Symbol t_f: changed Unit from “μs” to “ns” – Symbol C_b: changed Unit from “μs” to “pF” • Updated soldering information. 		
PCA9546A_4	20060829	Product data sheet	-	PCA9546A_3
PCA9546A_3 (9397 750 14318)	20050406	Product data sheet	-	PCA9546A_2
PCA9546A_2 (9397 750 13991)	20040929	Objective data sheet	-	PCA9546A_1
PCA9546A_1 (9397 750 13308)	20040728	Objective data sheet	-	-

16. Legal information

16.1 Data sheet status

Document status ^{[1][2]}	Product status ^[3]	Definition
Objective [short] data sheet	Development	This document contains data from the objective specification for product development.
Preliminary [short] data sheet	Qualification	This document contains data from the preliminary specification.
Product [short] data sheet	Production	This document contains the product specification.

[1] Please consult the most recently issued document before initiating or completing a design.

[2] The term 'short data sheet' is explained in section "Definitions".

[3] The product status of device(s) described in this document may have changed since this document was published and may differ in case of multiple devices. The latest product status information is available on the Internet at URL <http://www.nxp.com>.

16.2 Definitions

Draft — The document is a draft version only. The content is still under internal review and subject to formal approval, which may result in modifications or additions. NXP Semiconductors does not give any representations or warranties as to the accuracy or completeness of information included herein and shall have no liability for the consequences of use of such information.

Short data sheet — A short data sheet is an extract from a full data sheet with the same product type number(s) and title. A short data sheet is intended for quick reference only and should not be relied upon to contain detailed and full information. For detailed and full information see the relevant full data sheet, which is available on request via the local NXP Semiconductors sales office. In case of any inconsistency or conflict with the short data sheet, the full data sheet shall prevail.

16.3 Disclaimers

General — Information in this document is believed to be accurate and reliable. However, NXP Semiconductors does not give any representations or warranties, expressed or implied, as to the accuracy or completeness of such information and shall have no liability for the consequences of use of such information.

Right to make changes — NXP Semiconductors reserves the right to make changes to information published in this document, including without limitation specifications and product descriptions, at any time and without notice. This document supersedes and replaces all information supplied prior to the publication hereof.

Suitability for use — NXP Semiconductors products are not designed, authorized or warranted to be suitable for use in medical, military, aircraft, space or life support equipment, nor in applications where failure or malfunction of an NXP Semiconductors product can reasonably be expected to result in personal injury, death or severe property or environmental

damage. NXP Semiconductors accepts no liability for inclusion and/or use of NXP Semiconductors products in such equipment or applications and therefore such inclusion and/or use is at the customer's own risk.

Applications — Applications that are described herein for any of these products are for illustrative purposes only. NXP Semiconductors makes no representation or warranty that such applications will be suitable for the specified use without further testing or modification.

Limiting values — Stress above one or more limiting values (as defined in the Absolute Maximum Ratings System of IEC 60134) may cause permanent damage to the device. Limiting values are stress ratings only and operation of the device at these or any other conditions above those given in the Characteristics sections of this document is not implied. Exposure to limiting values for extended periods may affect device reliability.

Terms and conditions of sale — NXP Semiconductors products are sold subject to the general terms and conditions of commercial sale, as published at <http://www.nxp.com/profile/terms>, including those pertaining to warranty, intellectual property rights infringement and limitation of liability, unless explicitly otherwise agreed to in writing by NXP Semiconductors. In case of any inconsistency or conflict between information in this document and such terms and conditions, the latter will prevail.

No offer to sell or license — Nothing in this document may be interpreted or construed as an offer to sell products that is open for acceptance or the grant, conveyance or implication of any license under any copyrights, patents or other industrial or intellectual property rights.

Export control — This document as well as the item(s) described herein may be subject to export control regulations. Export might require a prior authorization from national authorities.

16.4 Trademarks

Notice: All referenced brands, product names, service names and trademarks are the property of their respective owners.

I²C-bus — logo is a trademark of NXP B.V.

17. Contact information

For more information, please visit: <http://www.nxp.com>

For sales office addresses, please send an email to: salesaddresses@nxp.com

18. Contents

1	General description	1
2	Features	1
3	Ordering information	2
3.1	Ordering options	2
4	Block diagram	3
5	Pinning information	4
5.1	Pinning	4
5.2	Pin description	5
6	Functional description	5
6.1	Device address	5
6.2	Control register	6
6.2.1	Control register definition	6
6.3	RESET input	7
6.4	Power-on reset	7
6.5	Voltage translation	7
7	Characteristics of the I²C-bus	8
7.1	Bit transfer	8
7.2	START and STOP conditions	8
7.3	System configuration	8
7.4	Acknowledge	9
7.5	Bus transactions	10
8	Application design-in information	11
9	Limiting values	12
10	Static characteristics	13
11	Dynamic characteristics	15
12	Package outline	17
13	Soldering of SMD packages	20
13.1	Introduction to soldering	20
13.2	Wave and reflow soldering	20
13.3	Wave soldering	20
13.4	Reflow soldering	21
14	Abbreviations	22
15	Revision history	23
16	Legal information	24
16.1	Data sheet status	24
16.2	Definitions	24
16.3	Disclaimers	24
16.4	Trademarks	24
17	Contact information	24
18	Contents	25

Please be aware that important notices concerning this document and the product(s) described herein, have been included in section 'Legal information'.



© NXP B.V. 2009.

All rights reserved.

For more information, please visit: <http://www.nxp.com>

For sales office addresses, please send an email to: salesaddresses@nxp.com

Date of release: 2 July 2009

Document identifier: PCA9546A_5