

PLEASE CHECK WWW.MOLEX.COM FOR LATEST PART INFORMATION

Part Number: [0444741811](#)
Status: **Active**
Description: 4.20mm (.165") Pitch Mini-Fit HCS™ Header, Dual Row, Vertical, Blind Mating, with Snap-in Plastic Peg PCB Lock, 18 Circuits, PA Polyamide Nylon 6/6 94V-2, without Drain Holes

Documents:

[3D Model](#) [Product Specification PS-44476-001 \(PDF\)](#)
[Drawing \(PDF\)](#) [RoHS Certificate of Compliance \(PDF\)](#)

Agency Certification

CSA LR19980
 UL E29179

General

Product Family PCB Headers
 Series [44474](#)
 Application Board-to-Board, Wire-to-Board
 Comments Square Pin|Solder Type
 Product Name Mini-Fit HCS™

Physical

Breakaway No
 Circuits (Loaded) 18
 Circuits (maximum) 18
 Color - Resin Natural
 Durability (mating cycles max) 30
 Flammability 94V-2
 Glow-Wire Compliant No
 Material - Metal High Performance Alloy (HPA)
 Material - Plating Mating Tin
 Material - Plating Termination Tin
 Material - Resin Nylon
 Number of Rows 2
 Orientation Vertical
 PC Tail Length (in) 0.138 In
 PC Tail Length (mm) 3.50 mm
 PCB Locator Yes
 PCB Retention Yes
 PCB Thickness Recommended (in) 0.070 In
 PCB Thickness Recommended (mm) 1.80 mm
 Packaging Type Tray
 Pitch - Mating Interface (in) 0.165 In
 Pitch - Mating Interface (mm) 4.20 mm
 Plating min: Mating (µin) 100
 Plating min: Mating (µm) 2.50
 Plating min: Termination (µin) 100
 Plating min: Termination (µm) 2.50
 Polarized to PCB Yes
 Shrouded Fully
 Stackable No
 Surface Mount Compatible (SMC) No
 Temperature Range - Operating -40°C to +105°C
 Termination Interface: Style Through Hole

Electrical

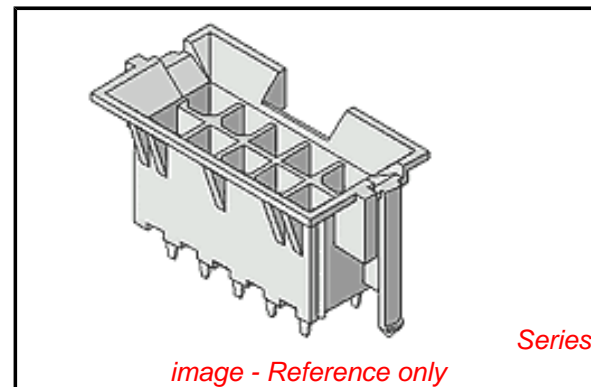

EU RoHS

ELV and RoHS Compliant
REACH SVHC
 Not Reviewed
Halogen-Free Status
Not Reviewed

China RoHS



Need more information on product environmental compliance?

Email productcompliance@molex.com
 For a multiple part number RoHS Certificate of Compliance, [click here](#)

Please visit the [Contact Us](#) section for any non-product compliance questions.

Search Parts in this Series

[44474Series](#)

Mates With

[42474](#) , [44475](#) , [44516](#) , [5557d](#)

Current - Maximum per Contact	11A
Voltage - Maximum	600V

Solder Process Data

Duration at Max. Process Temperature (seconds)	5
Lead-free Process Capability	Wave Capable (TH only)
Max. Cycles at Max. Process Temperature	1
Process Temperature max. C	260

Material Info**Reference - Drawing Numbers**

Product Specification	PS-44476-001, RPS-44476-001
Sales Drawing	SDA-44474-****

This document was generated on 03/25/2010

PLEASE CHECK WWW.MOLEX.COM FOR LATEST PART INFORMATION

SEE NOTE 14

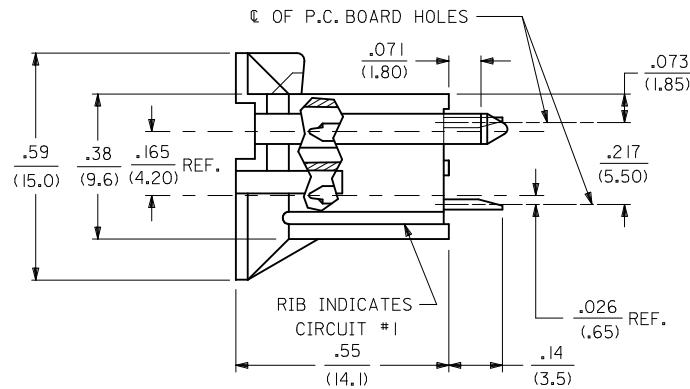
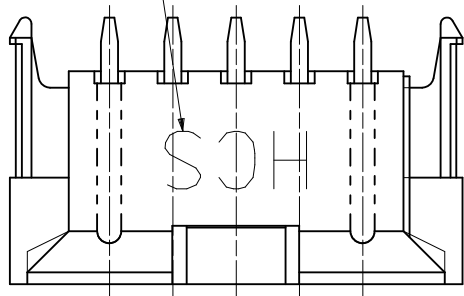

CIRCUIT SIZE	DIM. "A"	DIM. "B"	DIM. "C"	DIM. "D"	DIM. "E"
2	—	.21 (5.4)	.370 (9.40)	.425 (10.80)	.520 (13.20)
4	.17 (4.2)	.38 (9.6)	.535 (13.60)	.590 (15.00)	.685 (17.40)
6	.33 (8.4)	.54 (13.8)	.701 (17.80)	.756 (19.20)	.850 (21.60)
8	.50 (12.6)	.71 (18.0)	.866 (22.00)	.921 (23.40)	1.016 (25.80)
10	.66 (16.8)	.87 (22.2)	1.031 (26.20)	1.087 (27.60)	1.181 (30.00)
12	.83 (21.0)	1.04 (26.4)	1.197 (30.40)	1.252 (31.80)	1.346 (34.20)
14	.99 (25.2)	1.20 (30.6)	1.362 (34.60)	1.417 (36.00)	1.512 (38.40)
16	1.16 (29.4)	1.37 (34.8)	1.528 (38.80)	1.583 (40.20)	1.677 (42.60)
18	1.32 (33.6)	1.54 (39.0)	1.693 (43.00)	1.748 (44.40)	1.843 (46.80)
20	1.49 (37.8)	1.70 (42.2)	1.858 (47.20)	1.913 (48.60)	2.008 (51.00)
22	1.65 (42.0)	1.87 (47.4)	2.024 (51.40)	2.079 (52.80)	2.173 (55.20)
24	1.82 (46.2)	2.03 (51.6)	2.189 (55.60)	2.244 (57.00)	2.339 (59.40)

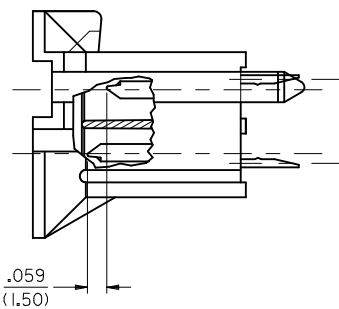
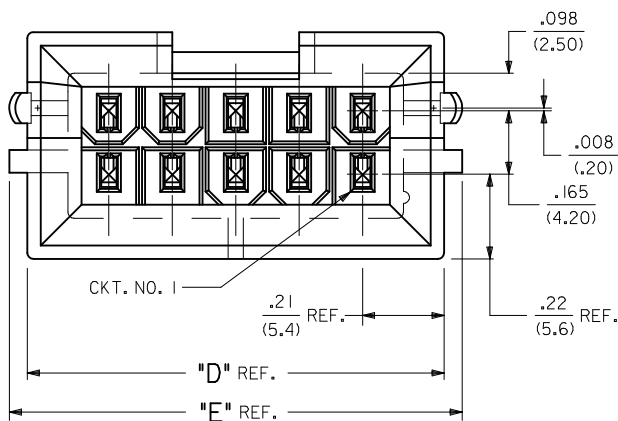

MATE-FIRST/BREAK-LAST DETAIL
(SEE NOTE 12)

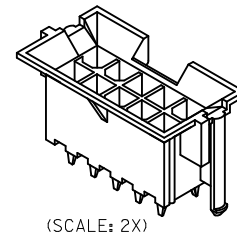

(SCALE: 2X)

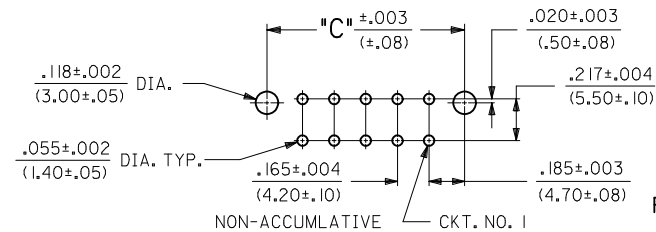

RECOMMENDED HOLE LAYOUT FOR .070/(1.78) MAX. THICK P.C. BOARD

(SEE NOTE 5)
(SCALE: 2X)

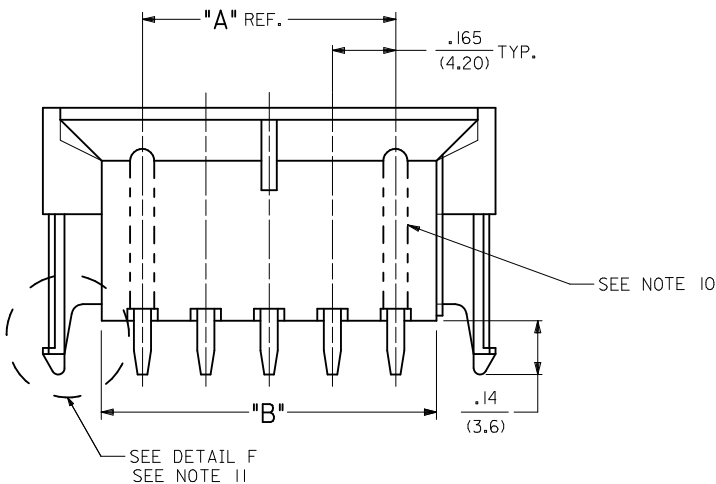
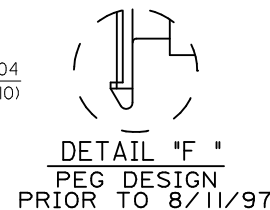

SEE DETAIL F
SEE NOTE 11

MODIFIED SHT 4 EC NO: UCP2010-0472 DRWN: JAGUILAR 2009/11/11 CHKD: JIBELL 2009/12/01 APPR: FSMITH 2009/12/01 G1	DESCRIPTION REV	QUALITY SYMBOLS ▽=0 ▽=0	GENERAL TOLERANCES (UNLESS SPECIFIED) mm INCH 4 PLACES ± --- ± --- 3 PLACES ± --- ± .010 2 PLACES ± 0.25 ± .015 1 PLACE ± 0.38 ± --- ANGULAR ± 1/2°	DIMENSION STYLE IN/MM DRAWN BY DATE GEP CHECKED BY DATE RJF APPROVED BY DATE RJF	SCALE 1:1 DESIGN UNITS INCH THIRD ANGLE PROJECTION	TITLE VERTICAL HEADER ASSEMBLY MINI-FIT HCS SERIES	MATERIAL NO. SEE CHARTS	DOCUMENT NO. SDA-44474-****	SHEET NO. 1 OF 6
		DRAFT WHERE APPLICABLE MUST REMAIN WITHIN DIMENSIONS THIS DRAWING CONTAINS INFORMATION THAT IS PROPRIETARY TO MOLEX INCORPORATED AND SHOULD NOT BE USED WITHOUT WRITTEN PERMISSION							

NOTES:

- 1) HOUSING MAT'L. & OPTIONS:
 1 = NYLON 6/6, U.L. 94V-2, COLOR: NATURAL, WITHOUT DRAIN HOLES.
 2 = NYLON 6/6, U.L. 94V-0, COLOR: NATURAL, WITHOUT DRAIN HOLES.
 3 = NYLON 6/6, U.L. 94V-2, COLOR: NATURAL, WITH DRAIN HOLES.
 4 = NYLON 6/6, U.L. 94V-0, COLOR: NATURAL, WITH DRAIN HOLES.
- 2) TERMINAL MAT'L.: C197 ALLOY.
- 3) 6-24 CKT. PARTS MATE WITH MINI-FIT JR. RECEPT.*5557, H.C.S. VERT. HEADER #44475 AND B.M.I. HEADER #42474. 2 & 4 CKT. PARTS MATE WITH HEADERS ONLY.
- 4) PART ALLOWS FOR UP TO .100/(2.54) MISALIGNMENT WITH MATING RECEPTACLE IN ANY DIRECTION. SEE MATING CONNECTOR DRAWINGS FOR SPECIFIC ALLOWANCES.
- 5) PART IS DESIGNED IN METRIC.
- 6) TERMINAL PLATING:
 *1 = POSTPLATE .000100/(.00254) MIN. BRIGHT TIN OVER .000050/(.00127) MIN. NICKEL.
 2 = POSTPLATE .000100/(.00254) MIN. BRIGHT TIN OVER .000050/(.00127) MIN. NICKEL.
 *THE PRIMARY SHIPPING CARTON WILL BE LABELED *COMPLIANT TO ROHS DIRECTIVE 2002/95/EC AND ELV ANNEX II OF DIRECTIVE 2002/53/EC*. CARTONS WITHOUT THIS LABEL MAY CONTAIN PRODUCT WITH TIN-LEAD PLATING.
- 7) PRODUCT SPECIFICATION AND PROCESSING PARAMETERS: SEE PS-44476-001.
- 8) CONNECTOR ASSEMBLIES ARE NOT TO BE MATED OR UNMATED WHILE CIRCUITS ARE LIVE.
- 9) ITEM NUMBERS PRECEDED BY AN "X" IN THE CHARTS ON THE FOLLOWING SHEETS ARE NOT AVAILABLE.
- 10) OPTIONAL RIBS MAY BE FOUND ON PARTS MANUFACTURED AFTER 08/11/97.
- 11) PARTS MANUFACTURED AFTER 8/15/97 MAY HAVE REVISED LOCK PEG.
- 12) CIRCUITS SHOWN PROVIDE CUSTOM MATE-FIRST/BREAK-LAST FEATURE. SEE CHART ON SHEET SIX FOR ASSEMBLIES WITH ADDITIONAL CUSTOM OPTIONS.
- 13) PACKAGING:
 1 = TRAY PER PK-42440-001.
 2 = TUBE PER PK-40873-015L.
- 14) PARTS PRODUCED AFTER JULY 1, 2004 WILL HAVE "HCS" MARKING INSTEAD OF BLACK STRIPE.

SEE SHEET 1 EC NO: UCP2005-1986 DRAWN: JSCHAFFER 2005/03/17 CHKD: 2005/03/21 APPR: YMARGULLI 2005/03/22	QUALITY SYMBOLS 	GENERAL TOLERANCES (UNLESS SPECIFIED)		DIMENSION STYLE IN/MM		SCALE 1:1	DESIGN UNITS INCH	THIRD ANGLE PROJECTION		
						DRAWN BY GEP	DATE	TITLE VERTICAL HEADER ASSEMBLY MINI-FIT HCS SERIES		
						CHECKED BY RJF	DATE	MATERIAL NO. SDA-44474-****		
						APPROVED BY RJF	DATE	DOCUMENT NO. SDA-44474-****		
		ANGULAR ±1/2°		DRAFT WHERE APPLICABLE MUST REMAIN WITHIN DIMENSIONS		SIZE C		SHEET NO. 3 OF 6		
THIS DRAWING CONTAINS INFORMATION THAT IS PROPRIETARY TO MOLEX INCORPORATED AND SHOULD NOT BE USED WITHOUT WRITTEN PERMISSION										

	13	12	11	10	9	8	7	6	5	4	3	2	1		
J	PLATING:	I (SEE NOTE 6)	PLATING:	I (SEE NOTE 6)	PLATING:	I (SEE NOTE 6)	PLATING:	I (SEE NOTE 6)	PLATING:	I (SEE NOTE 6)	PLATING:	I (SEE NOTE 6)			
	DRAINS:	WITHOUT DRAIN HOLES	DRAINS:	WITHOUT DRAIN HOLES	DRAINS:	WITH DRAIN HOLES	DRAINS:	WITH DRAIN HOLES	DRAINS:	WITHOUT DRAIN HOLES	DRAINS:	WITHOUT DRAIN HOLES			
	PEGS:	WITH PEGS	PEGS:	WITH PEGS	PEGS:	WITH PEGS	PEGS:	WITH PEGS	PEGS:	WITH PEGS	PEGS:	WITH PEGS			
	MAT'L:	94V-2 [NATURAL]	MAT'L:	94V-0 [NATURAL]	MAT'L:	94V-2 [NATURAL]	MAT'L:	94V-0 [NATURAL]	MAT'L:	94V-2 [NATURAL]	MAT'L:	94V-0 [NATURAL]			
	PACKAGING:	TRAY (SEE NOTE I3)	PACKAGING:	TRAY (SEE NOTE I3)	PACKAGING:	TRAY (SEE NOTE I3)	PACKAGING:	TRAY (SEE NOTE I3)	PACKAGING:	TUBE (SEE NOTE I3)	PACKAGING:	TUBE (SEE NOTE I3)			
I		ITEM NO.	CKTS	ITEM NO.	CKTS	ITEM NO.	CKTS	ITEM NO.	CKTS	ITEM NO.	CKTS	ITEM NO.	CKTS		
	X	44474-0211	2	X	44474-0221	2	X	44474-0231	2	X	-	2	X	-	2
		44474-0411	4		44474-0421	4		44474-0431	4		44474-3001	4		44474-3013	4
		44474-0611	6	X	44474-0621	6	O	44474-0631	6	X	-	6	X	-	6
	X	44474-0811	8	X	44474-0821	8	X	44474-0831	8	X	-	8	X	-	8
		44474-1011	10		44474-1021	10		44474-1031	10		44474-3004	10		44474-3016	10
	X	44474-1211	12	X	44474-1221	12	X	44474-1231	12	X	-	12	X	-	12
		44474-1411	14		44474-1421	14		44474-1431	14		44474-3006	14		44474-3018	14
	X	44474-1611	16	X	44474-1621	16	X	44474-1631	16	X	-	16	X	-	16
		44474-1811	18		44474-1821	18		44474-1831	18		44474-3008	18		44474-3020	18
	X	44474-2011	20	X	44474-2021	20	X	44474-2031	20	X	-	20	X	-	20
	X	44474-2211	22	X	44474-2221	22	X	44474-2231	22	X	-	22	X	-	22
		44474-2411	24		44474-2421	24		44474-2431	24		44474-3011	24		44474-3023	24

G	PLATING:	I (SEE NOTE 6)	PLATING:	I (SEE NOTE 6)	PLATING:		PLATING:		PLATING:		PLATING:		
	DRAINS:	WITH DRAIN HOLES	DRAINS:	WITH DRAIN HOLES	DRAINS:		DRAINS:		DRAINS:		DRAINS:		
	PEGS:	WITH PEGS	PEGS:	WITH PEGS	PEGS:		PEGS:		PEGS:		PEGS:		
	MAT'L:	94V-2 [NATURAL]	MAT'L:	94V-0 [NATURAL]	MAT'L:		MAT'L:		MAT'L:		MAT'L:		
	PACKAGING:	TUBE (SEE NOTE I3)	PACKAGING:	TUBE (SEE NOTE I3)	PACKAGING:		PACKAGING:		PACKAGING:		PACKAGING:		
F		ITEM NO.	CKTS	ITEM NO.	CKTS	ITEM NO.	CKTS	ITEM NO.	CKTS	ITEM NO.	CKTS	ITEM NO.	CKTS
	X	-	2	X	-	2		-	2		-	2	
		44474-3025	4		44474-3037	4			4			4	
	X	-	6	X	-	6		-	6		-	6	
	X	-	8	X	-	8		-	8		-	8	
		44474-3028	10		44474-3040	10			10			10	
	X	-	12	X	-	12		-	12		-	12	
		44474-3030	14		44474-3042	14			14			14	
	X	-	16	X	-	16		-	16		-	16	
		44474-3032	18		44474-3044	18			18			18	
	X	-	20	X	-	20		-	20		-	20	
	X	-	22	X	-	22		-	22		-	22	
		44474-3035	24		44474-3047	24			24			24	

* ITEMS PRECEDED BY "X" ARE NOT AVAILABLE
 ITEMS ON THIS PAGE ARE STANDARD PRODUCT. REFER TO
 SHEET SIX FOR PRODUCT WITH CUSTOM OPTIONS.
 "O" = OBSOLETE

MODIFIED CHART EC NO: UCP2010-0472 DRWN: JAGUILAR 2009/11/11 CHKD: J.BELL 2009/12/01 APPR: F.SMITH 2009/12/01 G1	QUALITY SYMBOLS ▽=0 ▽=0	GENERAL TOLERANCES (UNLESS SPECIFIED) <table border="1"> <tr> <th></th> <th>mm</th> <th>INCH</th> </tr> <tr> <td>4 PLACES</td> <td>± .005</td> <td>± .0002</td> </tr> <tr> <td>3 PLACES</td> <td>± .005</td> <td>± .0002</td> </tr> <tr> <td>2 PLACES</td> <td>± .005</td> <td>± .0002</td> </tr> <tr> <td>1 PLACE</td> <td>± .005</td> <td>± .0002</td> </tr> </table>		mm	INCH	4 PLACES	± .005	± .0002	3 PLACES	± .005	± .0002	2 PLACES	± .005	± .0002	1 PLACE	± .005	± .0002	DIMENSION STYLE IN/MM DRAWN BY DATE ERH CHECKED BY DATE MB APPROVED BY DATE RE	SCALE 1:1 DESIGN UNITS INCH THIRD ANGLE PROJECTION	TITLE VERTICAL HEADER ASSEMBLY MINI-FIT HCE SERIES	MATERIAL NO. SEE CHART	DOCUMENT NO. SDA-44474-****	SHEET NO. 4 OF 6
		mm	INCH																				
	4 PLACES	± .005	± .0002																				
	3 PLACES	± .005	± .0002																				
2 PLACES	± .005	± .0002																					
1 PLACE	± .005	± .0002																					
DRAFT WHERE APPLICABLE MUST REMAIN WITHIN DIMENSIONS		MOLEX INCORPORATED		THIS DRAWING CONTAINS INFORMATION THAT IS PROPRIETARY TO MOLEX INCORPORATED AND SHOULD NOT BE USED WITHOUT WRITTEN PERMISSION																			