

PLEASE CHECK WWW.MOLEX.COM FOR LATEST PART INFORMATION

Part Number: [0190700125](#)
Status: **Active**
Description: InsulKrimp™ Ring Tongue Terminal for 10-12 AWG Wire, Stud Size 10, Length 27.33mm (1.076"), Mylar Tape Carrier

Documents:

[Drawing \(PDF\)](#) [RoHS Certificate of Compliance \(PDF\)](#)
[Product Specification PS-19902-009 \(PDF\)](#)

Agency Certification

CSA LR18689
 UL E32244

General

Product Family Ring and Spade Terminals
 Series [19070](#)
 Crimp Quality Equipment Yes
 Mil-Spec N/A
 Product Name InsulKrimp™
 Type Ring

Physical

Barrel Type Closed
 Color - Resin Natural
 Flammability 94V-2
 Insulation PVC
 Material - Plating Mating Tin
 Packaging Type Adhesive Tape on Reel
 Stud Size 10 (M5)
 Wire Insulation Diameter 6.40mm (.250") max.
 Wire Size AWG 10, 12
 Wire Size mm² 0.40 - 0.60

Material Info

Old Part Number C-228-10XT

Reference - Drawing Numbers

Product Specification PS-19902-009
 Sales Drawing CCD20101



EU RoHS

ELV and RoHS Compliant
REACH SVHC
 Not Reviewed
Halogen-Free Status
Not Reviewed

China RoHS



Need more information on product environmental compliance?

Email productcompliance@molex.com
 For a multiple part number RoHS Certificate of Compliance, [click here](#)

Please visit the [Contact Us](#) section for any non-product compliance questions.

Search Parts in this Series

[19070Series](#)

Application Tooling | [FAQ](#)

Tooling specifications and manuals are found by selecting the products below. Crimp Height Specifications are then contained in the Application Tooling Specification document.

Global

Description	Product #
Crimp Dies for MTA-100 Tape Applicator used in 3BF Press, MTA-105 Tape Applicator used in TM-2000™ Press, and ATP-301 Air Crimping Press for Mylar Tape Mounted Terminals	0192880179
Mini-Mac™ Applicator	0638851500

This document was generated on 04/06/2010

PLEASE CHECK WWW.MOLEX.COM FOR LATEST PART INFORMATION

NOTES: $\pm .001$

- ① MAT'L: COPPER(STOCK TKN. $\frac{040}{1.02}$)
- ② INSULATION: ELECTRO-TIN (.0003 MIN.)
- ③ INSULATION: MOLDED PVC (YELLOW)

STUD SIZES: ($\pm .005$)

02 = .094	209 = 209
04 = .119	413 = 413
06 = .146	
08 = .173	
10 = .198	
14 = .265	
56 = .328	
38 = .390	
76 = .453	
12 = .515	

"UL" LISTING # E32244
 "CSA" LISTING # 18689

ALL DIMENSIONS = $\frac{\text{INCHES}}{\text{MM}}$

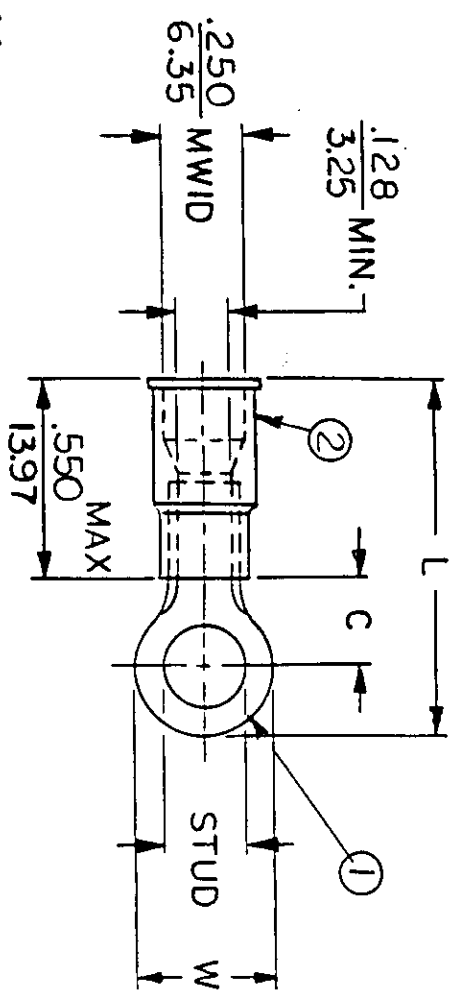

MWID = MAXIMUM WIRE
 INSULATION DIAMETER
 WIRE SIZE: 12-10 AWG
 WIRE SIZE: 40-60 MM²

PART NUMBER	"W" ±.010	"C" MIN.	"L" MAX.	AVAILABLE STUD SIZES
C-201-	$\frac{.750}{19.05}$	$\frac{.611}{15.52}$	$\frac{1.571}{39.90}$	14X, 56X, 38X, 76X, 12X
C-228-	$\frac{.375}{9.53}$	$\frac{.303}{7.70}$	$\frac{1.076}{27.33}$	04X, 06X, 08X, 10X, 209X
C-230-	$\frac{.530}{13.46}$	$\frac{.393}{9.98}$	$\frac{1.243}{31.57}$	10X, 14X, 56X, 38X
C-236-	$\frac{.282}{7.16}$	$\frac{.306}{7.77}$	$\frac{1.032}{26.21}$	04X, 06X, 08X
C-240-	$\frac{.592}{15.04}$	$\frac{.466}{11.84}$	$\frac{1.347}{34.21}$	10X, 14X, 56X, 38X, 209X, 413X

DIMENSIONAL TOLERANCES UNLESS OTHERWISE SPECIFIED		REFERENCE	SCALE:	NTS	DATE	TITLE:
FRAC.	DEC.	ANG.	DRWN. BY:	JJ	10-31-84	RING TONGUE TERMINAL
±	±	±	CHKD. BY:	GZ	11-26-84	INSULKRIMP 200-SERIES
			APPRD. BY:			

FILE NO. C-CD-201-01



DWG. NO. A CUSTOMER DWG.