

T1L2003028-SP

30 W, 28V, 500 MHz—2 GHz, Powerband™ LDMOS RF Power Transistor

Introduction

The T1L2003028-SP is a POWERBAND™ discrete LDMOS, enhancement mode RF Power transistor designed to operate from 500MHz to 2GHz in wide-band circuits. The device has an instantaneous band-width P1dB output power of 30watts across the entire band when operated in the TriQuint wide-band test fixture. The T1L2003028-SP can also be used in narrow band applications and is rated at 45Watts P1dB at 2GHz.

Figure 1. Available Packages



Features

- Exceptional Instantaneous band-width performance from 500MHz – 2GHz
- Increased efficiency results in significant advantages
 - Smaller and lighter systems
 - Reduced system component costs
 - Reduced energy consumption
- Typical Performance ratings
 - Wide-Band 500MHz-2GHz (as tested in TriQuint Wideband Fixture)
 - 10dB gain
 - 45% Efficiency
 - 30Watt P1dB
 - Narrow Band up to 2GHz
 - 14dB gain
 - 59% efficiency
 - 45Watt P1dB

Table 1. Thermal Characteristics

Parameter	Sym	Value	Unit
Thermal Resistance, Junction to Case:	R_JC	1.3	°C/W

Table 2. Absolute Maximum Ratings*

Parameter	Sym	Value	Unit
Drain-source Voltage	VDSS	65	Vdc
Gate-source Voltage	VGS	-0.5, +15	Vdc
Drain Current—Continuous	ID	4.25	Adc
Total Dissipation at TC = 25 °C:			
T1L2003028-SP	PD	135	W
Derate Above 25 °C:			
T1L2003028-SP	—	0.77	W/°C
Operating Junction Temperature	TJ	200	°C
Storage Temperature Range	TSTG	-65, +150	°C

* Stresses in excess of the absolute maximum ratings can cause permanent damage to the device. These are absolute stress ratings only. Functional operation of the device is not implied at these or any other conditions in excess of those given in the operational sections of the data sheet. Exposure to absolute maximum ratings for extended periods can adversely affect device reliability.

Table 3. ESD Rating*

T1L2003028-SP	Minimum (V)	Class
HBM	500	1B
MM	50	A
CDM	1500	4

* Although electrostatic discharge (ESD) protection circuitry has been designed into this device, proper precautions must be taken to avoid exposure to ESD and electrical overstress (EOS) during all handling, assembly, and test operations. Agere employs a human-body model (HBM), a machine model (MM), and a charged-device model (CDM) qualification requirement in order to determine ESD-susceptibility limits and protection design evaluation. ESD voltage thresholds are dependent on the circuit parameters used in each of the models, as defined by JEDEC's JESD22-A114B (HBM), JESD22-A115A (MM), and JESD22-C101A (CDM) standards.

Caution: MOS devices are susceptible to damage from electrostatic charge. Reasonable precautions in handling and packaging MOS devices should be observed.

Preliminary Data Sheet
Subject to Change

T1L2003028-SP

30 W, 28V, 500 MHz—2 GHz, Powerband™ LDMOS RF Power Transistor

Electrical Characteristics

Recommended operating conditions apply unless otherwise specified: TC = 30 °C.

Table 4. dc Characteristics

Parameter	Symbol	Min	Typ	Max	Unit
Off Characteristics					
Drain-source Breakdown Voltage (VGS = 0, ID = 200 μA)	V(BR)DSS	65	—	—	Vdc
Gate-source Leakage Current (VGS = 5 V, VDS = 0 V)	IGSS	—	—	1.3	μAdc
Zero Gate Voltage Drain Leakage Current (VDS = 28 V, VGS = 0 V)	IDSS	—	—	75	μAdc
On Characteristics					
Forward Transconductance (VDS = 10 V, ID = 1.0 A)	GFS	—	3	—	S
Gate Threshold Voltage (VDS = 10 V, ID = 400 μA)	VGS(TH)	—	—	4.8	Vdc
Gate Quiescent Voltage (VDS = 28 V, IDQ = 450 mA)	VGS(Q)	—	3.5	—	Vdc
Drain-source On-voltage (VGS = 10 V, ID = 1.0 A)	VDS(ON)	—	0.25	—	Vdc

Table 5. RF Characteristics

Parameter	Symbol	Min	Typ	Max	Unit
Dynamic Characteristics					
Input Capacitance (VDS = 28 Vdc, VGS = 0, f = 1 MHz)	CISS	—	73	—	pF
Output Capacitance (VDS = 28 Vdc, VGS = 0, f = 1 MHz)	COSS	—	23	—	pF
Reverse Transfer Capacitance (VDS = 28 Vdc, VGS = 0, f = 1 MHz)	CRSS	—	1.2	—	pF
Functional Tests, Instantaneous Band-Width (Tested in TriQuint's Wide-Band Test Fixture)					
Gain @ P1dB, 500MHz-2GHz (VDS = 28 V, POUT = 30 W, IDD = 200 mA)	G	—	10	—	dB
P1dB, 500MHz-2GHz (VDS = 28 V, POUT = 30 W, IDD = 200 mA)	P1dB	—	30	—	W
Power Added Efficiency, 500MHz-2GHz (VDS = 28 V, POUT = 30 W, IDD = 200 mA)	—	—	45	—	%
Functional Tests, Narrow Band RF Performance (1GHz)					
Linear Power Gain (VDS = 28 V, POUT = 6 W, IDQ = 450 mA)	GL	19	20	—	dB
Output Power (VDS = 28 V, 1 dB compression, IDQ = 450 mA)	P1dB	45	60	—	W
Drain Efficiency (VDS = 28 V, POUT = P1dB, IDQ = 450 mA)	—	—	59	—	%
Third-order Intermodulation Distortion (100 kHz spacing, VDS = 28 V, POUT = 45 WPEP, IDQ = 450 mA)	IMD	—	-31	—	dBc
Input Return Loss	IRL	—	10	—	dB
Ruggedness (VDS = 28 V, POUT = 45 W, IDQ = 450 mA, f = 880 MHz, VSWR = 10:1, all angles)	No degradation in output power.				

Preliminary Data Sheet
Subject to Change

T1L2003028-SP

30 W, 28V, 500 MHz—2 GHz, Powerband™ LDMOS RF Power Transistor

Typical Instantaneous Wide-Band Performance Data, 500MHz-2GHz
(tested in TriQuint wide-band fixture)

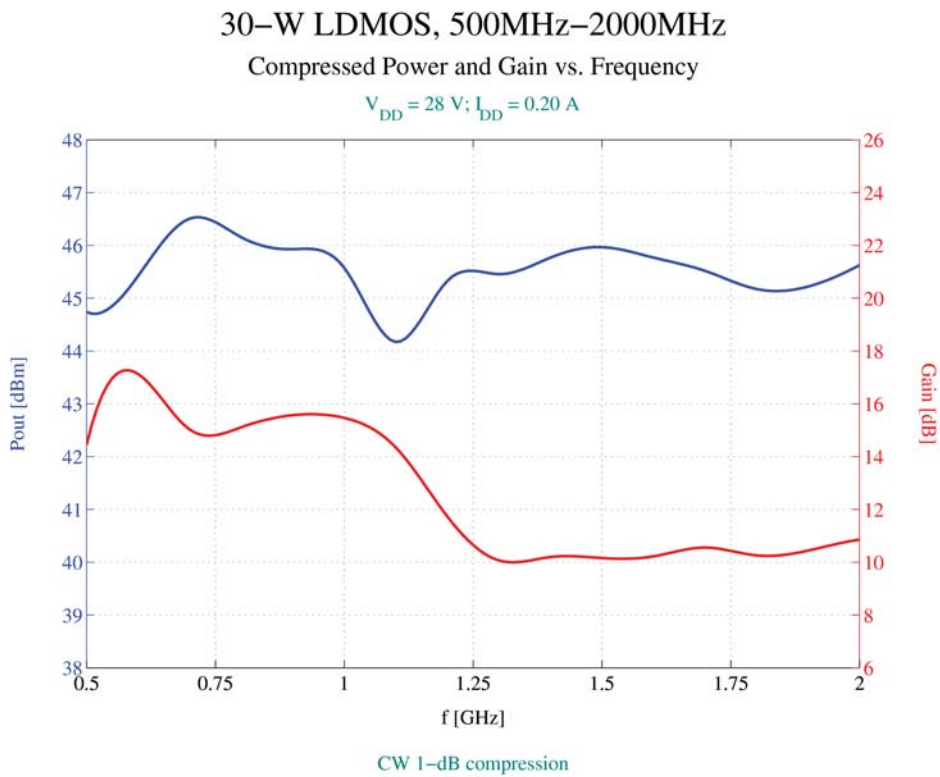
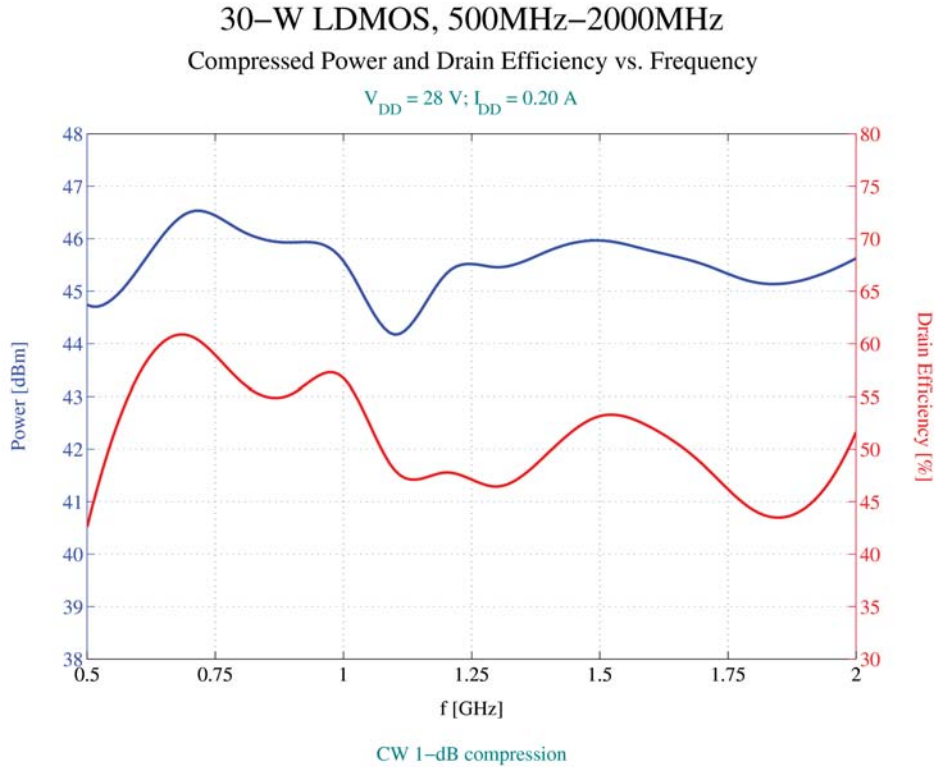

Sheet
nge

T1L2003028-SP

30 W, 28V, 500 MHz—2 GHz, Powerband™ LDMOS RF Power Transistor

Package Dimensions

Note: All dimensions in inches. Scale 8:1

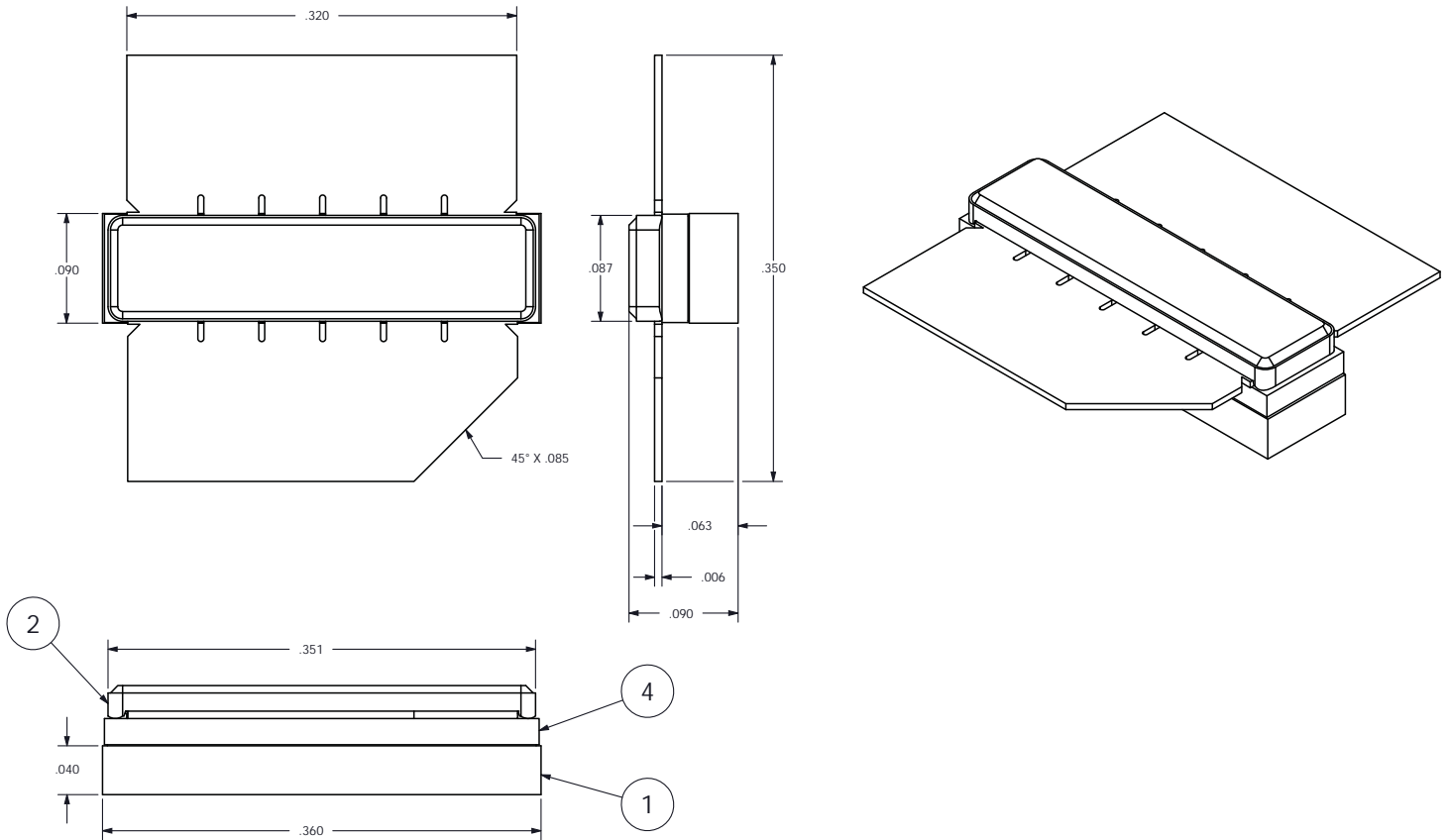

Preliminary Data Sheet
Subject to Change